



VOLUME 3  
DRAINAGE

**VOL. 3-04**  
**PUMP STATION AND FORCEMAIN**  
**DESIGN GUIDELINES**

**FEBRUARY 2022**

**TERMS OF USE**

The "City of Edmonton Design and Construction Standards Volume 3: Drainage", henceforth known as "Volume 3", is made available for use in the City of Edmonton effective as of February 28, 2022. Volume 3-04: Pump Station and Forcemain Design Guidelines has been developed to establish standards and guidelines which align with EPCOR's expectations in the design and construction of drainage infrastructure within the City of Edmonton. Volume 3-04 is presented as accurate and complete as of the effective date and all care has been taken to confirm the accuracy of the information contain herein. The views expressed herein do not necessarily represent those of any individual contributor. No part of these standards absolves any user from the obligation to exercise their professional judgment and follow good practice. Should any user have questions as to the intent or accuracy of any specification or drawing herein, or concern that conflict may exist between the manufacture's or suppliers' recommended installation procedures and Volume 3-04, the user is advised to seek clarification by sending an email to [DRENG@epcor.com](mailto:DRENG@epcor.com).

Professional Engineer Seal	Permit to Practice	Responsible for Sections
<p>Ahmad Mohsin, P.Eng. Manager, System Control and Intregation</p>	<div style="border: 1px solid black; padding: 5px;"> <p align="center"><b>PERMIT TO PRACTICE EPCOR WATER SERVICES INC.</b></p> <p>RM SIGNATURE: <u><i>Anthony Nardi</i></u></p> <p>RM APEGA ID #: <u>91408</u></p> <p>DATE: <u>Feb. 18, 2022</u></p> <p><b>PERMIT NUMBER: P006368</b> The Association of Professional Engineers and Geoscientists of Alberta (APEGA)</p> <p align="center">Anthony Nardi, P.Eng. Senior Manager, Drainage Operations</p> </div>	<p>Appendix A: 1.2 – 1.4, and 2.3 – 2.4</p>
 <p><b>FEB 18, 2022</b> <b>ID # 89472</b> Tony Liao, P.Eng. Project Manager, Electrical Engineering Process</p>		<p>Appendix A: All Sections except 1.2 – 1.4, and 2.3 – 2.4</p>
<p>Wimal (Darsh) Nawaratna, P.Eng. Manager, Mechanical Design</p>	<p>Abhishek Bhargava, P.Eng. Senior Manager, Drainage Engineering</p>	<p>All Sections in Vol. 3-04</p>

Volume 3 in this update is split into six sub-volumes, as following tables, for easy reference and timely update of individual sub-volume to address industry requirements and technological advancements.

New Section	Old Section	Description	Date
<b>Vol. 3-01: Development Planning Procedure and Framework</b>			
1	1	Planning	December 2021
2	2	Planning Approval Process - General	December 2021
3	3	Planning and Design Studies	December 2021
4	4	Typical Area Master Plan Requirements	December 2021
5	5	Typical Neighbourhood Design Report Requirements	December 2021
6	6	Typical Requirements for Hydrogeotechnical Impact Assessments	December 2021
7	7	Sanitary Sewer - Policy, Goals and Objectives	December 2021
8	12	Storm Drainage System - Policy, Goals and Objectives	December 2021
Appendix A	Appendix G	Pump Station Decision Model	December 2021
<b>Vol. 3-02: Stormwater Management and Design Manual</b>			
1	13	Stormwater Runoff Analysis	December 2021
2	13	Tables of Runoff and Rainfall Information	February 2022
3	15	Major Conveyance System Design	December 2021
4	16	Stormwater Management Facility Design	February 2022
5	17	LID Facility Design	February 2022
6	18	Lot Grading and Surface Drainage Design	December 2021
Appendix A	Appendix B	Computer Model Transfer Requirement Check List	December 2021
<b>Vol. 3-03: Design Guidelines</b>			
1	8	Sanitary Sewer Design Criteria	February 2022
2	14	Minor Conveyance System Design	December 2021
3	19	Sewers, Appurtenances and Structures	February 2022
4	20	Structural Design for Pipe	December 2021
Appendix A	Appendix C	Catch Basin Inlet Capacity Curves	December 2021
Appendix B	Appendix D	Guidelines for the Design and Installation of Rigid Gravity Sewer Pipe in the City of Edmonton	December 2021
Appendix C	Appendix E	Guidelines for the Design and Construction of Flexible Thermoplastic Pipe in the City of Edmonton	December 2021
3.11.5 ii and iii	Appendix H	Appendix H: Outfall Structure Monitoring embedded in Sections 3.11.5 ii and iii	December 2021
<b>Vol. 3-04: Pump Station and Forcemain Design Guidelines</b>			
1	9	Sanitary Wastewater Pumping Systems	December 2021
2	10	General Design Requirements for Pump Stations	February 2022
3	11	Design of Sewage Forcemains	December 2021
Appendix A	Appendix A	Design Guidelines for Electrical and Control Systems for Wastewater Pump Stations	February 2022
2.13.2 ii and iii	Appendix F	Appendix F: Pumpwell Unit Confined Space Entry Fall Arrest and Rescue System updated and embedded in Sections 2.13.2 ii and iii	December 2021
<b>Vol. 3-05: Drawing Requirements, Approvals and Asset Acceptance/Transfer</b>			
1	21	Detailed Engineering Drawings	December 2021
2	22	As-Built Drawing Requirements	February 2022
3	23	Project Acceptance	December 2021
4	-	Product Approval Procedure	December 2021

New Section	Old Section	Description	Date
<b>Vol. 3-06: Construction Specifications</b>			
1	02412	Tunnel Excavation Using Sequential Excavation Method	December 2021
2	02415	Tunnelling by Tunnel Boring Machines	December 2021
3	02422	Steel Ribs and Lagging	December 2021
4	02423	Shotcrete Tunnel Lining	December 2021
5	02426	Pipe Jacking	December 2021
6	02427	Precast Concrete Tunnel Lining	December 2021
7	02435	Tunnel Liner Grouting	December 2021
8	02441	Microtunnelling	December 2021
9	02444	Shaft Construction	December 2021
10	02445	Bored Undercrossings	December 2021
11	02446	Horizontal Directional Drilling	December 2021
12	02531	Sewage Forcemains	December 2021
13	02535	Sewers	December 2021
14	02538	Sewer Services	December 2021
15	02559	Factory Applied Pipe Insulation	December 2021
16	02620	Subdrains	December 2021
17	02631	Manholes and Catch Basins	December 2021
18	02632	Drainage Manholes Frames and Covers	December 2021
19	02640	Corrugated Steel Pipe Culvert	December 2021
20	02645	Precast Concrete Box Sewers	December 2021
21	02952	Temporary Flow Control	December 2021
22	02953	Cleaning Sewers	December 2021
23	02954	Inspection of Sewers	December 2021
24	02955	Pipe Bursting	December 2021
25	02956	Joint Grouting Concrete Sewers	December 2021
26	02957	Relining Sewers	December 2021
27	02958	Leakage Testing of Sewers	December 2021
28	02959	Deflection Testing of Flexible Pipe	December 2021
29	03310	Concrete for Water and Drainage Structures	December 2021

**Vol 3-06: Standard Drawings**

New Drawing Number	Old Drawing Number	Description	Date
DR-02-04-01	-	Typical Davit Base, Guard Rail and Hatch Layout on Control Structure	November 2021
DR-02-05-01	7001	Bioretention Cleanouts	October 2021
DR-02-05-02	7003	Soil Cell Cleanouts	October 2021
DR-06-13-01	7980	Trench Bedding Types	October 2021
DR-06-13-02	7981	Concrete Pipe Butt Joint Detail	October 2021
DR-06-14-01	7063	Standard Riser Connections to Storm and Sanitary Sewers in Common Trench	October 2021
DR-06-17-01	7005	Standard 600 Catch Basin with Type 2A Grating and Frame	October 2021
DR-06-17-02	7006	Standard 600 Catch Basin with Type K-7 Grating and Frame	October 2021
DR-06-17-03	7007	Neck Section Details for Type 4A, 6B and 8 Grating and Frame	October 2021

New Drawing Number	Old Drawing Number	Description	Date
DR-06-17-04	7008	Neck Section Details for Type F-51 and K-7 Grating and Frame	October 2021
DR-06-17-05	7009	Standard 900 Catch Basin with Type DK-7 Grating and Frame	October 2021
DR-06-17-06	7010	Standard 900 Catch Basin with Type F-51 Grating and Frame with Side Inlet	October 2021
DR-06-17-07	7011	Standard 1200 CB Manhole with Type 6B or 8 Grating and Frame	October 2021
DR-06-17-08	7012	Standard 1200 CB Manhole with Type F-51 Grating and Frame with Side Inlet	October 2021
DR-06-17-09	7013	Standard 1200 Manhole for Piping up to 600mm Diameter with Type 6A Cover and Frame	October 2021
DR-06-17-10	7014	Neck Section Details for Standard 1200 Manhole	October 2021
DR-06-17-11	7020	Benching Detail for Standard 1200 Manhole	October 2021
DR-06-17-12	7021	Safety Steps for Manholes	October 2021
DR-06-17-13	7030	Grade Rings	October 2021
DR-06-17-14	7031	Rings/Tops	October 2021
DR-06-17-15	7032	Slab Tops for Standard 900 Catch Basin	October 2021
DR-06-17-16	7033	Slab Top for Standard 900 Catch Basin	October 2021
DR-06-17-17	7034	Slab Tops for Standard 1200mm Manhole	October 2021
DR-06-18-01	7040	Type 2A Two Piece Side Inlet Catch Basin Grating and Frame	October 2021
DR-06-18-02	7041	Type 4A Two Piece Side Inlet Catch Basin Manhole Grating and Frame	October 2021
DR-06-18-03	7042	Type 8 Catch Basin Manhole Grating and Frame	October 2021
DR-06-18-04	7043A/B	Type 6 Standard Manhole Frame, Cover and Round Catch Basin Cover	October 2021
DR-06-18-05	7043C	Type 6S Manhole Frame and Cover	October 2021
DR-06-18-06	7044	Type 80 Cover and Floating Type Manhole Frame	October 2021
DR-06-18-07	7045	Type K-7 and DK-7 Catch Basin Frame and Grating	October 2021
DR-06-18-08	7047	Type F-51 Three Piece Catch Basin Frame and Grating with Side Inlet	October 2021
DR-06-18-09	7048	Type F-51 Two Piece Curb Component Frame and Grating	October 2021
DR-06-18-10	7050	Type 41 Manhole Frame and Cover	October 2021
DR-06-18-11	7051	Type 6C Slotted Flat Cover to be used on Type 6 Frame for Air Release	October 2021
DR-06-19-01	7062	Culvert End Riprap	October 2021

The following is a list of revisions in **Vol. 3-04: Pump Station and Forcemain Design Guidelines**.

Section	Changes	Date
2.13.2 ii and iii	Appendix F: Pumpwell Unit Confined Space Entry Fall Arrest and Rescue System updated and embedded in Sections 2.13.2 ii and iii.	December 2021
2.1.3	Clarified vehicle access requirement.	February 2022
2.11.8	Added combination valves requirement.	February 2022
2.13.2 iv	Added Davit base installation requirement.	February 2022
2.13.3 i	Replaced “the vapour-proof fluorescent” with “LED”.	February 2022
2.19.1 1 <sup>st</sup> bullet	Deleted “or peristaltic pump”.	February 2022
Appendix A: 1.3	Added support for Ethernet/IP protocol in SCADA, included correction on remote control capability of some field locations.	February 2022



Section	Changes	Date
	Added support for remote output control in non-PLC devices in some cases, minor corrections to site references (e.g. field vs generic location) and design criteria definitions.	
Appendix A: 1.4	Added requirement for a tamper switch on our panels to secure our panels, generalized part numbers by using “or equivalent” references.	February 2022
Appendix A: 2.3	Generalized part numbers by using “or equivalent” references.	February 2022
Appendix A: 2.4	Added the requirement to review, test and authenticate PLC, SCADA and Data Acquisition Systems code by referencing APEGA’s standard of “Guideline for Professional Responsibilities in Developing Software, V1.0, February 2016”, Section 2.4”, updated alarm and status list.	February 2022

---

**TABLE OF CONTENTS**

<b>1.0</b>	<b>SANITARY WASTEWATER PUMPING SYSTEMS.....</b>	<b>1</b>
1.1	Initial Considerations .....	1
1.2	Basis for Detailed Design - Report Requirements.....	1
1.3	Other Applicable Standards.....	2
1.4	Approval of Design by Other Authorities .....	2
<b>2.0</b>	<b>GENERAL DESIGN REQUIREMENTS FOR PUMP STATIONS.....</b>	<b>2</b>
2.1	Location Considerations .....	2
2.2	Pumping Station Configuration Considerations.....	2
2.3	Building Requirements.....	3
2.4	Pumping Capacity Requirements .....	4
2.5	Operational Reliability/Emergency Backup Provisions.....	4
2.6	Staging of Wastewater Pumping Facilities .....	5
2.7	Detailed Design Requirements for Wastewater Pumping Stations .....	5
2.8	Wastewater Inlet Sewer.....	6
2.9	Wet Well Size and Detail .....	6
2.10	Pumps.....	7
2.11	Pump, Valve and Piping Arrangement .....	8
2.12	Pump Control and Instrumentation Requirements .....	9
2.13	Maintenance and Operational Provisions.....	10
2.14	Heating .....	13
2.15	Sump Pump .....	13
2.16	Site Requirements .....	13
2.17	Operation and Maintenance Manual .....	14
2.18	Requirements for Activated Carbon Odour Control Units (OCU) in Pump Stations .....	15
2.19	EPCOR Chemical Dosing Requirements .....	18
<b>3.0</b>	<b>DESIGN OF SEWAGE FORCEMAINS.....</b>	<b>18</b>
3.1	Forcemain Size Considerations.....	18
3.2	Flow Velocity Limits .....	19
3.3	Design Pressures .....	19
3.4	Surge Protection Devices .....	19
3.5	Slope.....	19
3.6	Alignment.....	19
3.7	Air Release .....	19
3.8	Blowoff Valves .....	19
3.9	Vacuum Relief .....	19
3.10	Forcemain Outlet .....	19
3.11	Design Documentation on Engineering Drawings.....	20
3.12	Requirements for Locating Forcemains.....	20
3.13	Requirements for Forcemain Inspection and Cleaning .....	20



---

**LIST OF TABLES**

Table 1: Additional Information for Floor Mount Type Davit Bases .....11

**LIST OF FIGURES**

Figure 2.1: Typical Pumping Station Arrangement.....5  
Figure 2.2: Pictorial Views of the Acceptable Davit Bases.....11  
Figure 2.3: Station Identification Sign Example.....14

**APPENDICES**

***Appendix A:*** Design Guidelines for Electrical and Control Systems for Wastewater Pump Stations



## 1.0 SANITARY WASTEWATER PUMPING SYSTEMS

### 1.1 Initial Considerations

Extension of sanitary servicing by means other than gravity flow sewers shall be considered only in cases where physically or economically insurmountable constraints cannot be resolved, dictating a requirement for a wastewater pumping station. This must be justified through the AMP study for a development area. The evaluation process defined in the Vol. 3-01 Appendix A: Pump Station Decision Model shall be used when conducting pump station vs. gravity sewer option analysis.

### 1.2 Basis for Detailed Design - Report Requirements

1.2.1 The basis for detailed design of wastewater pumping stations should be defined in the NDR for the respective development area. In support of the detailed design for a wastewater pumping station, a summary report should be prepared. This report is to address the following items.

- A brief description of the project and purpose;
- The justification for a wastewater pumping facility;
- Design period;
- Area serviced;
- Population densities and ultimate total population;
- Commercial and industrial contributing areas;
- Projected average, peak and minimum daily dry weather flow, related to anticipated development staging;
- Average and peak wet-weather flow;
- Infiltration and extraneous flow allowances;
- Design flow rates proposed;
- Number, type, capacity and motor power of the proposed pumping units;
- Forcemain design basis;
- System head curves, including head computations for the pumping system;
- System and pump curves illustrating power, efficiency, and family of curves;
- A control philosophy for process pump operations and valves;
- Process and instrumentation diagrams (P&ID) for lift stations and control gates; The information should include level start and stop, motor and pump description, all instrumentation;
- Transient analysis for all complex pump stations; If the station is simple, a signed and stamped letter from a professional engineer stating that no transient issues will occur will be sufficient;
- Sewage detention times in the wet well and forcemain under various operating conditions;
- Cost estimates;
- Projected present value of operating costs including those for power, operation and maintenance over the design life of the facility
- Ventilation requirements;
- Heating, ventilation, and air conditioning (HVAC) calculation details;
- Odour control measures;
- Emergency backup systems, including overflow provision and a standby power generator, to address mechanical, electrical or operator failures or catastrophic events;
- Environmental considerations and impacts;

- Station location considerations and accessibility;
- Staging provisions;
- Public consultation process undertaken or proposed;
- Additional information as requested by the City.

### 1.3 Other Applicable Standards

1.3.1 In addition to meeting the requirements as laid out in this chapter, the design and construction of wastewater pumping facilities must meet all the current requirements of other governmental authorities having jurisdiction, including:

- Alberta Environment and Parks;
- Alberta Occupational Health and Safety;
- Electrical Protection Branch - Alberta Municipal Affairs and Housing ;
- Plumbing and Gas Safety Branch - Alberta Municipal Affairs and Housing ; and
- Building Standards Branch - Alberta Municipal Affairs and Housing as laid out in the Alberta Building Code.

1.3.2 Additional requirements for individual wastewater pumping stations may be imposed by the City as conditions warrant.

### 1.4 Approval of Design by Other Authorities

Engineering drawings for wastewater pumping stations may have to be submitted to AEP for review as a condition of the Letter of Authorization for the project issued pursuant to the Alberta Environmental Protection and Enhancement Act. The issuance of a Letter of Acknowledgement by AEP, may be deemed necessary by AEP, before construction of the facility can begin. It shall be the responsibility of the Developer and engineering consultants to prepare and make all necessary submissions and applications to AEP and to satisfy any requirements as necessary to obtain that agency's approval for the wastewater pumping station (refer to Section 1.3.4 - Vol. 3-05: Drawing Requirements, Approvals and Asset Acceptance/Transfer).

## 2.0 GENERAL DESIGN REQUIREMENTS FOR PUMP STATIONS

### 2.1 Location Considerations

#### 2.1.1 Proximity to other Land Uses

Special consideration should be given to the location of wastewater pumping stations relative to existing or proposed adjacent development, in order to minimize the facilities aesthetic impact in terms of visibility, odour and noise. The location of wastewater pumping stations in the immediate proximity of school sites and playgrounds should be avoided if possible. Safety and security measures are to be given special consideration in such cases.

#### 2.1.2 Floodproofing

Pumping stations are to be located outside of the limits of any area subject to surface ponding or inundation by surface flow during major runoff events so that they are accessible in all weather conditions.

#### 2.1.3 Vehicle Access

Pump stations must be designed in such a way that heavy maintenance vehicles such as vac-trucks can safely access the wet well hatches for cleaning activities. In order to allow safe passage for Operation & Maintenance vehicles, consider width and truck turning radius of the access road and speed limit of the main road that is allowing entry to the access road.

### 2.2 Pumping Station Configuration Considerations

2.2.1 Wet well/dry well configuration for pumping station is preferred. Wet well only option is acceptable

- subject to the requirements stated in the following section.
- 2.2.2 The wet well (submersible pump only) configuration is acceptable for facilities with pumping requirements of less than approximately 75 kW and if the pump is to be located 8.0 m or less below ground elevation in the wet well, facilitating maintenance. The Consultant shall meet with EPCOR Drainage Services to assure accessibility issues are discussed and addressed in design, and the required horizontal and vertical reach is available. The capacity for lifting equipment must be provided.
- 2.2.3 As pumping requirements increase, the designer should give more preference to provision of separate wet and dry wells, with pumps located in the dry well.
- 2.2.4 Where technically viable options exist in the choice of the type of pumps or in the station arrangement, a present value analysis should be undertaken to determine the most cost-effective equipment and arrangement, taking into account such factors as:
- cost of the facility and its life;
  - energy cost over the life of the facility;
  - life and replacement cost of the pumping equipment, including ancillary items such as switch gear, lifting and ventilation equipment;
  - the cost of operation and maintenance;
  - reliability;
  - safety;
  - local availability of repair services and spare parts and equipment suppliers;
  - flood proofing;
  - nuisance to residents of adjacent homes, or users of parks, facilities and developments in the area;
  - the facility as a possible source of contamination to the environment.
- 2.2.5 The design is to address the required functional lifetime of the facility structure. This is deemed to be 50 years unless the Engineer specifically approves a different lifetime. The pumping equipment should be assumed to receive a major overhaul involving renewal of the wearing components at 7 to 10 year intervals, dependent on service conditions.
- 2.2.6 The analysis should bear in mind that the pumping units may have to be replaced every 15 years, as many manufacturers do not hold spare parts for pumps that have been out of production for longer than this period.
- 2.3 Building Requirements**
- 2.3.1 A building is required at all pumping stations to house all electrical and control equipment and provide tool storage space, office space and a washroom.
- 2.3.2 All heating and ventilating equipment and valves are to be housed in the building or a dry well. The building or dry well is to be completely isolated from the pumping station wet well and provision for access to the wet well shall only be from the outside, through doors or access hatches with suitable locking devices. Materials in dry well are to be fiberglass or 316 stainless steel.
- 2.3.3 Locking systems for pumping facilities shall be electronic and programmable, in accordance with the standards developed by EPCOR Drainage Services.
- 2.3.4 Anti-graffiti coating or easily cleaned material shall be applied on the outer surface of the building to allow for the removal of graffiti without damage to the building.
- 2.3.5 To prevent the contamination of potable water supplies at pump stations, a break tank, pressure pump, and pressure tank must be provided as required by the Alberta Government Standards and Guidelines for Municipal Waterworks, Wastewater, and Storm Drainage Systems. An air gap of at least 150 mm above the maximum flood line or the spill line of the tank is required. The Consultant shall provide written documentation that shows it meets provincial legislation.

## 2.4 Pumping Capacity Requirements

### 2.4.1 Design Capacity

Pumping equipment shall be selected with capacity in excess of the maximum expected flow as determined by established engineering practice. In all cases, the design capacity flow rate for a wastewater pumping station shall exceed the expected maximum flow rate determined in accordance with the requirements of Section 1.1 to 1.7 - Vol. 3-03: Design Guidelines.

### 2.4.2 Mechanical Redundancy

A minimum of two pumps are required for each pumping station and three is preferred. Generally these should be identical and interchangeable. Where only two pumping units are provided they shall each be of the same pumping capacity and each unit, operating independently, shall be capable of pumping at the design capacity flow rate for the station under the service conditions. Where three or more pumping units are provided they shall have pumping capacity such that with the largest unit out of service, the remaining units operating in parallel are capable of pumping at the design capacity flow rate for the station under the service conditions.

## 2.5 Operational Reliability/Emergency Backup Provisions

2.5.1 The design of wastewater pumping facilities must identify and anticipate all events that affect the functioning of the facility. Provisions must be made to mitigate the consequences of failure of the facility by any mode, so as to prevent property damage, the endangerment of public health or environmental damage.

### 2.5.2 Power Supply Reliability Provisions

- i. Independent power supply sources: Whenever it is feasible, the electric power supply to the facility is to be provided from two or more independent distribution sources.
- ii. Emergency standby power: In cases where redundant electric power supply is not feasible, provision of on-site installed emergency standby power equipment is required.

Refer to the Design Guidelines for Electrical and Control Systems for Wastewater Pumping Stations, located in **Appendix A**, for details on the above.

### 2.5.3 Alarm Telemetry - General Requirements

Automated remote sensing and SCADA equipment shall be provided at each wastewater pumping station. This equipment shall provide for detection of the status of selected operating conditions and transmission of appropriate alarms to the monitoring facilities established and operated by EPCOR. Refer to the Design Guidelines for Electrical and Control Systems for Wastewater Pumping Stations in **Appendix A**.

### 2.5.4 Overflow Connections

In anticipation of the potential operational failure of a wastewater pumping facility and its backup provisions, the feasibility of providing a gravity overflow is to be evaluated. The elevation and hydraulic capacity of overflow connections are to be optimized to minimize the risk of basement flooding due to sanitary system backup.

### 2.5.5 Overflows to Storm Drainage Systems

Overflow connections to storm drainage sewers, storage facilities, natural water courses or surface outfall points require special justification and are subject to receipt of approval from AEP before acceptance by the City. Overflow connections to storm sewers are preferred rather than overflows to watercourses.

### 2.5.6 Overflows to Sanitary Sewer Systems.

Provision of an overflow connection to an adjacent or downstream sanitary sewer system is required whenever it is feasible. This connection should permit the overflow to bypass the pumping station. If this is not possible, then overflow from the pumping station wet well will be permitted.

### 2.5.7 Prevention of Backflow from Overflows.

Overflow connections shall be provided with suitable means to prevent backflow from the overflow into the pumping station.

2.5.8 Corrosion Considerations

Copper pipe shall not be used for water service connection due to the presence of H<sub>2</sub>S gas at pumping stations. Non-metallic approved alternatives or that confirm to applicable standards shall be used instead. The use of brass control valves shall be minimized where feasible. Stainless steel or corrosion resistant material shall be used for supporting pipe.

2.6 Staging of Wastewater Pumping Facilities

2.6.1 Where warranted, due to economic considerations or to accommodate extended periods of development of the contributing area, the provision of pumping capacity and/or the construction of a wastewater pumping station may be staged appropriately. Where such staging is proposed, all stages are to be defined and related to the anticipated development scenario for the contributing area. A plan of action is to be established as part of the initial design to define the process for the implementation of future stages. The plan should consider continuity of service, the responsibility and financial arrangements for future stage implementation and the most cost-effective method for implementing the capacity changes.

2.6.2 Interim Wastewater Pumping Stations - Design Criteria

There is no relaxation of the criteria for design and construction for pumping stations that are anticipated to be required for a limited time period.

2.7 Detailed Design Requirements for Wastewater Pumping Stations

Refer to **Figure 2.1** for typical arrangement and components of wastewater pumping stations.

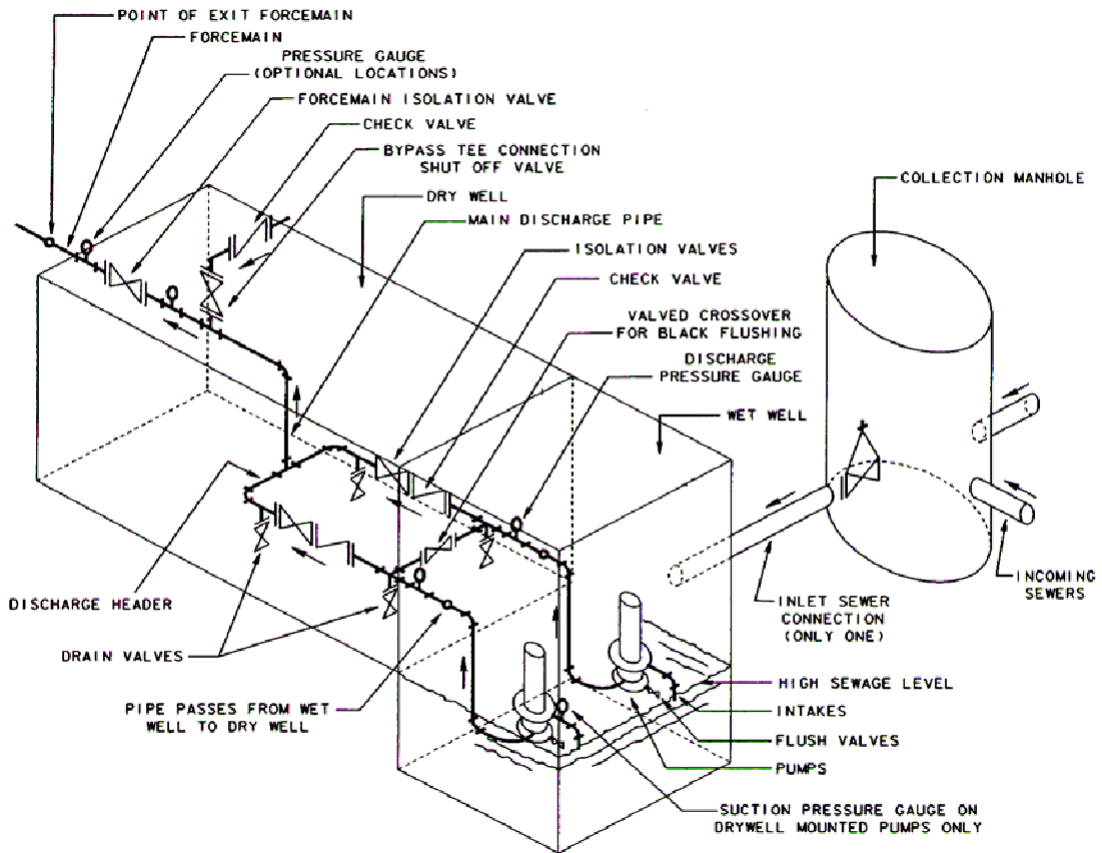

Figure 2.1: Typical Pumping Station Arrangement

## 2.8 Wastewater Inlet Sewer

### 2.8.1 Single Sewer Entry to Wet Wells

Only one sewer connection shall be provided into a wet well to convey sewage from the contributing collection system.

### 2.8.2 Collection Manhole

If more than one sewer enters the site or is required to be connected to the pumping station, a collection manhole shall be provided as a junction point for all incoming sewers. Appropriate stubs are to be provided for future connections. The access covers on collection manholes or manholes that are to be used for bypass pumping shall be 900 mm diameter vault covers or 900 mm square hatches.

### 2.8.3 Inlet Sewer Elevation

Excessive entrainment of air into the flow stream entering the wet well should be avoided to prevent entrained air from reducing pump performance or causing loss of prime. Provisions necessary to address this may include drop tubes inside wet wells of small facilities, or grade adjustments or a drop manhole upstream from the pumping station to lower the elevation of the inlet to the station. However, inlet sewers shall not enter the wet well at an elevation lower than the normal high liquid level for the design capacity flow rate.

### 2.8.4 Inflow Shutoff Provisions

An inflow shutoff stop log installation is to be provided on the inlet to the wet well so that inflow to the wet well can be stopped. Shutoff valves or slide gates should be installed in the first manhole upstream from the pumping station. The shutoff equipment shall be of a type and materials suitable for raw sewage service. The installation of shutoff devices within the wet well is not recommended unless there is no alternative. Under these circumstances provisions must be made for operating them without entry to the wet well.

## 2.9 Wet Well Size and Detail

### 2.9.1 Size Considerations

- i. Wet wells are to be of adequate size to suit equipment, operator access requirements and active volume considerations.
- ii. Well access should be designed appropriately to accommodate and facilitate wet well cleaning. This requires either a very large hatch or two hatches to allow for hoses/equipment/ropes and worker rescue operations. This also requires a ladder and a small platform at an elevation to facilitate wand washing of the walls.
- iii. Aluminum doors or hatches are recommended for access to wet wells. Installation of electrical equipment and wiring within the wet well is to be avoided.
- iv. Lifting chains in wet wells shall be nickel plated or galvanized and have a molybdenum based corrosion protection coating.
- v. To minimize dead storage volume, the depth from the "pump off" level to the floor of the wet well should be kept to an acceptable minimum. The required depth is to be dictated by suction pipe inlet conditions, pump manufacturer's requirements for submergence or cooling, net positive suction head, priming requirements and vortex control.
- vi. Wet wells must be sized small enough to minimize total retention time, the time sewage is held in the wet well and any rising forcemain, and yet be large enough to control the frequency of pump starts. The maximum retention time in the wet well should not exceed 30 minutes for the design minimum flow rate anticipated when the contributing area is fully developed. Total retention time in the wet well and forcemain should be kept to a minimum (generally less than 4 h) to avoid anaerobic fermentation and the resultant production of odorous, hazardous and corrosive gases. Otherwise, provisions must be made to control anaerobic conditions. It is desirable to have a wet well with sufficient active volume so that all sewage within the discharge forcemain is replaced during one pumping cycle, especially if sags exist in the forcemain profile.

- vii. Wet wells should be sized large enough to maximize pump life by decreasing the frequency of pump starts. Accordingly, sufficient storage between switching levels should be provided to limit the number of pump starts, normally to 6 per hour with pump alternation and 10 per hour with the standby pump inoperative. The manufacturers' recommendations with regard to the allowable frequency of pump starts for the specific size and type of motor are to be satisfied.

#### 2.9.2 Wet Well Shape and Benching

- i. Wet wells are to be arranged and benched to limit dead spaces where solids can accumulate and to provide smooth, uniform and unobstructed flow to the pump suction influence zones. Wet well floors should have a minimum slope of 1:1 to a hopper-type bottom. The horizontal area of the hopper bottom should be no larger than necessary for the proper installation of the pump or suction pipe.
- ii. The cross-sectional area and shape of the wet well above the benching are to be constant or increasing from the bottom towards the top.

#### 2.9.3 Vortex Prevention

Suction elbows, baffle plates, vortex breakers, or drop tubes are to be provided as required.

#### 2.9.4 Corrosion Considerations - Wet Well

- i. All bolts, nuts and other fasteners used in wet well areas shall be 316 stainless steel and all supports, brackets, gratings, ladders and other structures shall be of corrosion resistant materials. Gratings shall be either fiberglass or 316 stainless steel.
- ii. Aluminium doors or hatches are recommended for access to wet wells. Installation of electrical equipment and wiring within the wet well is to be avoided whenever it not essential there. If wiring is within wet well, it shall be sealed to prevent H<sub>2</sub>S migration to junction boxes, electrical panel, etc.
- iii. Lifting chains in wet wells shall be nickel plated or galvanized and have a molybdenum-based corrosion protection coating. Systems where the chain is not required to stay in the raw sewage are preferred (see also Section **2.13**).
- iv. Concrete surfaces in wet wells shall be coated to reduce sulphide corrosion (example of corrosion resistant materials are: Carboline Reactimine 760; Spectrashield; Sewergard Glaze No.210G Clayburn Refractories; 680 Ceilcote Primer, 664 Ceilcote; 610 Ceilcote ceilpatch; Valespar78 hi build epoxy).

#### 2.9.5 Grease Control for Wet Wells

- i. Wet wells are to have a non-stick coating or similarly functioning surface installed, to reduce the amount of grease building up on the walls and to facilitate wet well cleaning. The coating shall also provide corrosion protection for concrete. See Section **2.9.4 iv**.
- ii. A mixer/sprayer or similar system to limit grease built up shall be installed in the wet well.

#### 2.9.6 Clogging Prevention

To deal with ragging (pump plugging) issues, provisions should be included in the design process for full installation of a comminutor/grinder device to reduce pump clogging.

### 2.10 Pumps

#### 2.10.1 Pump Selection Considerations

- i. Submersible pumps are preferred for all situations (wet or dry mounted). Where dry wells could become flooded, design of the cables, seals, and connectors and electronic controls (etc.) should allow dry mounted pumps to operate under water. Pumps are to be removable and replaceable without dewatering the wet well or requiring personnel to enter the wet well.
- ii. Pump impellers shall be of a non-clog design and be capable of passing spherical solids of 75 mm diameter.

- iii. Pumps are to be selected which to provide optimum efficiencies at actual operating points. The power rating of a motor should not be exceeded by the pump at any operating condition on the characteristic curve of the pump.
- iv. Flush valves or recirculation pipes from the pump discharge to the wet well are to be provided for occasional aeration and suspension of grit and solids in wet well. Provision shall be made for automating the cleaning and agitation system, based on timing or other factors.

#### 2.10.2 Pump Electrical Requirements

Main pump motors shall operate on 600 volt, 3 phase power. Refer to the Design Guidelines for Electrical and Control Systems for Wastewater Pumping stations, in **Appendix A**, for details of electric power, panels and connections.

### 2.11 Pump, Valve and Piping Arrangement

#### 2.11.1 Pump and Discharge Header Arrangement

Two or more pumps shall be connected in a parallel arrangement to a common header, which must be located within a control building or dry well, such that all isolation and check valves are accessible for operation and maintenance.

#### 2.11.2 Provision for Pump Removal

Pumps are to be connected such that when any pump is removed for servicing the remaining pump or pumps remain operational. Submersible pumps shall be removable and replaceable without the need for dewatering the wet well or for personnel to enter the wet well.

#### 2.11.3 Pump Suction Arrangement

Each pump shall have its own individual intake and/or suction connection to the wet well.

#### 2.11.4 Suction Crossover (Wet Well/Dry Well Pumping Stations)

In wet well/dry well stations, a full-sized valved crossover pipe shall be installed connecting the individual suction pipes, and shutoff valves shall be placed on the pump suction pipes between the crossover connections and the pumps. The piping and valve arrangement shall be suitable to permit isolation of any individual pump for maintenance or removal.

#### 2.11.5 Provision for Back Flushing

Piping and valves shall be provided to back flush each pumping unit and its suction, using the discharge flow from another pump directed through the discharge of the unit being flushed.

#### 2.11.6 Piping and Valve Requirements

- i. Minimum size of piping: The minimum diameter for all pump suction and discharge piping shall be 100 mm nominal. Piping shall be sized such that flow velocity does not exceed 1.8 m/s in suction piping or 3.5 m/s in the discharge header within the pumping station. Flow velocities should not be less than 0.75 m/s, to maintain solids in suspension. Discharge piping should be as large as possible while maintaining this minimum velocity for scouring.
- ii. Piping materials: All piping within wastewater pumping stations shall be corrosion resistant material. All pipes in wet well area must be stainless steel 316 and welded. If needed bolted flanges can be used but only as a final alternative and they must be accessible and approved by maintenance crews. Buried pipe under the facility and within the excavation shall be a minimum of standard wall welded steel, with yellow jacket exterior and cement or epoxy interior; or galvanized pipe with polyken tape wrapped exterior.
- iii. Pressure rating for piping: The pressure rating for piping within the station shall suit the service requirement, however the minimum rating shall be 900 kPa.

#### 2.11.7 Check Valves

- i. Pump discharge: A check valve shall be installed on the discharge line between each pump and an isolation valve. These check valves should not be mounted in a vertical position. When vertical



mounting of a check valve is necessary, it shall not be of the flapper type.

- ii. Bypass T: A check valve shall be installed after the bypass T-connection shutoff valve to prevent backflow to any connected auxiliary pump. This valve may be mounted vertically if necessary.
- iii. Check valve types: Check valves shall be supplied with external levers and spring and limit switches to indicate and prove valve opening.

#### 2.11.8 Combination Valves

Combination air release-vacuum relief (air-vac) valves shall be required especially at high points in wastewater force mains. The vent piping of the valves shall be routed to the wet well.

#### 2.11.9 Isolation Valves

- i. Shutoff valves shall be included on the discharge lines from each pump between the pump check valve and the discharge header within the dry well. Shutoff valves shall also be included on the suction side of the pump. This will permit isolation of each pumping unit and check valve for removal or repair. Full port (ball valves, minimum 1" diameter) suitable for sewage application, shall be used instead of plug valves or gate valves.
- ii. Bleed valves should be installed between the discharge valve and the pump header in the dry well in order to relieve pressure when servicing pumps and to allow pump priming.
- iii. Station isolation valves are to be located outside of the carriageway. Avoid installation within access roads to the stations whenever possible. Isolation gates should be rising stem with acrylic so that operator can see if gate has reached open/closed or has failed.

2.11.10 A forcemain isolation valve shall be included on the main discharge pipe where it connects to the discharge forcemain leaving the facility, to isolate the forcemain from the pump station.

#### 2.11.11 Bypass Provisions

A T-connection with a shutoff valve on the branch is to be provided on the main discharge pipe within each pumping station, upstream from the Forcemain Isolation Valve. The arrangement is to allow for either bypassing of the station using auxiliary pumping equipment, or bypassing the forcemain and pumping to an alternative outlet line. The unconnected end of the T-connection must be oriented to face toward an access hatch or entryway to facilitate the connection of the auxiliary pump discharge or outlet line. The emergency bypass connection shall be a 4" ball Bauer coupling.

#### 2.11.12 Provisions for Removal of Valves and Equipment

Provisions shall be made in the piping for removal of all valves and equipment. Appropriately located vent and drain valves shall be provided to permit drainage of all piping to facilitate valve and equipment removal.

### 2.12 Pump Control and Instrumentation Requirements

Refer to the Design Guidelines for Electrical and Control Systems for Wastewater Pumping Stations, in **Appendix A**.

#### 2.12.1 Control Panel Location and Floodproofing.

The control panel must be located so that it cannot be flooded under any foreseeable circumstances. Control panels shall be mounted on a concrete base or plinth, or steel support posts founded in concrete bases that ensure stability of the control panel.

#### 2.12.2 Pressure Gauges

Taps with shutoff valves suitable for portable quick-connect pressure gauges are to be provided on each suction and discharge pipe at suitable locations.

- i. Gauge taps shall be installed on the suction and discharge side of all dry well mounted pumps, on the discharge pipe from all wet well mounted pumps and on the main discharge to the forcemain. Pump discharge gauge taps should be located between the pump discharge and the discharge check valve.

- ii. Gauges should be a compound pressure/vacuum type, equipped with a diaphragm seal and isolation valves. Gauges provided for the discharge should be liquid-filled with a maximum range of approximately twice the working pressure.
- iii. Pressure gauges shall be mounted on a nearby wall or floor mounted on a galvanized, steel stand, 1.2 m above the floor and connected to the gauge taps with suitably pressure-rated hose.

## 2.13 Maintenance and Operational Provisions

### 2.13.1 Pump and Equipment Removal

- i. Permanent hoist equipment and access hatches are to be provided to permit removal and replacement of any piece of station equipment requiring routine maintenance or replacement. Hoists and beams should allow for placement of equipment onto service vehicles without double handling or use of mobile cranes. Hoists and beams must be robust, allowing for dynamic loads in case of hoist failure. Load rating for beam and hoist in wet well conditions must include provision for the additional load caused by ragging.
- ii. As an alternative in specific cases, appropriate vehicle access and adequate access hatches may be provided to allow the use of exterior mobile cranes.
- iii. For wet well pump installations, the provision and arrangement of lifting equipment is to be such that the necessity for personnel to enter the wet well for removal of equipment is minimized.
- iv. Lifting equipment should have sufficient capacity to handle the heaviest load anticipated, including an allowance for dynamic forces due to load shifting and debris loads, safe working load on the beams of at least 1.5x expected pump size. The capacity of all lifting equipment is to be clearly posted and the safe working load marked on hoist beams. Eyebolts in the walls and/or ceilings should be provided for rigging chain hoists or come-alongs where hoists are heavier than 20 kg.
- v. A load-rated swivel shall be installed between the load chain and the equipment attachment point. Systems to accomplish this that are compatible with the portable electric chain hoists (Kito) used by EPCOR Drainage Services. The hoist system should also not require chains residing in the sewage to pass through the lifting mechanism at any point during pump removal to prevent grit build-up within the hoist mechanism.

### 2.13.2 Access into Station Structures

- i. Suitable and safe means of access shall be provided to all equipment requiring inspection or maintenance and to the wet well for inspection and cleaning.
- ii. Stairways and ladders, including fall arrest hoops and rest platforms shall comply with the requirements of Occupational Health and Safety. All stairs shall be of a non-skid type. Areas that are designated as confined spaces shall have a system of rescue made available. This shall include standard davit bases to be installed at access openings and the provision for a straight line lifting rescue path out of confined spaces.
- iii. Details of acceptable davit bases

Information is provided for guidance in the detailed design of mechanical drainage facilities where provision for fall arrest and rescue is required. Designers are required to follow all applicable health and safety codes and standards. For required safety equipment, manufactures should be consulted to check the latest revision of their product specifications. All safety product specifications must be submitted to EPCOR for reference.

Instruction for davit base installation:

- Davit base anchor bolt proof load test must be certified by a professional engineer and certification shall be submitted to EPCOR
- Contact [DRENG@epcor.com](mailto:DRENG@epcor.com) for anchor bolt proof load test values
- Davit base shall be designed per OH&S code and associated CSA codes considering rescue and inspection of the facility

- Guard rail or other structures shall not interfere with davit base and operation of the davit arm system
- Offset floor mount davit base shall be installed in such a way that the proposed fall arrest davit arm is at 0° orientation with respect to the davit base

**Table 1: Additional Information for Floor Mount Type Davit Bases**

Type	Max. Offset	Rotation / Degree	Comments
Offset Floor Mount	36"	From -30° to 30°	Single entry access
Center Floor Mount	36"	360°	Two or more entry access

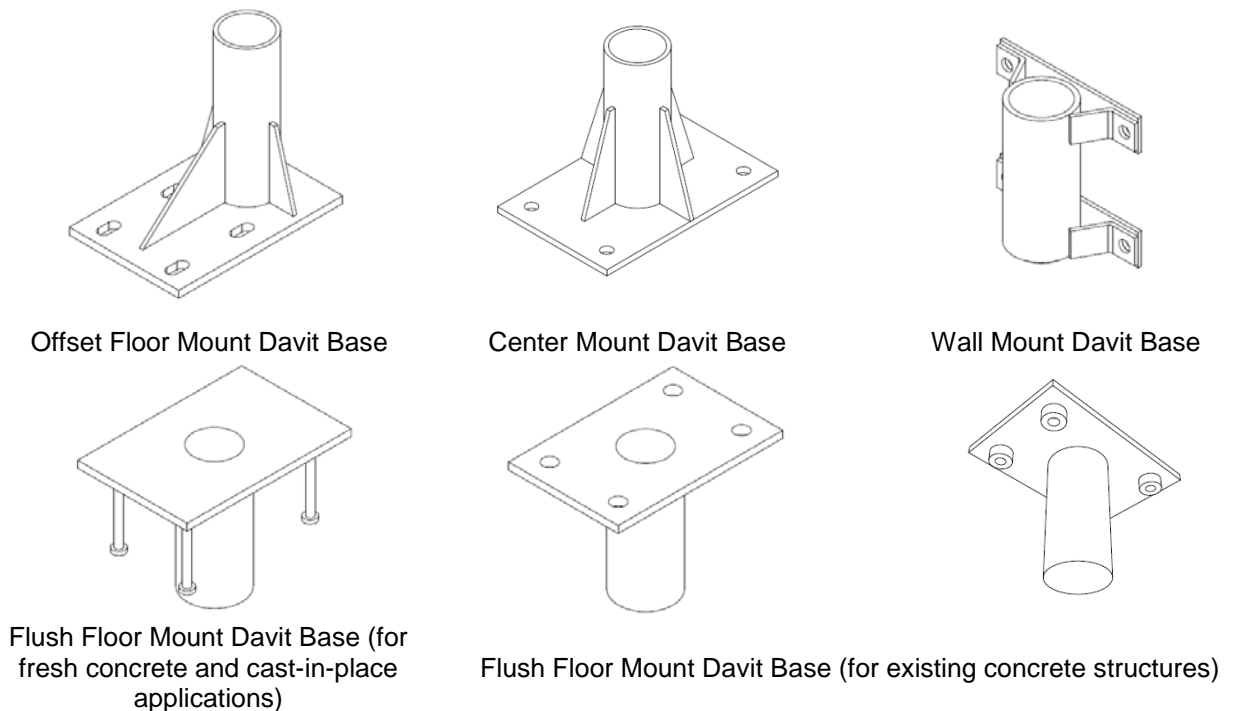

**Figure 2.2: Pictorial Views of the Acceptable Davit Bases**

iv. Davit base installation

Design engineer shall include davit base installation specifications in the design drawing. Specifications should include anchor bolt, adhesive, proof load testing (not required for cast-in-place anchors for new concrete slabs), minimum ambient temperature during installation, anchor hole drilling and cleaning.

- v. Access into wet wells shall be from the outside and not through buildings or dry wells. All access points to wet wells and dry wells shall have straight drop point to bottom of the structure to facilitate rescue activities. Straight drop access point shall be equipped with fall protection davit base and railing. Anchor point is to be fall protection anchor. Anchor points need to be labelled as whether they are travel restriction or fall protection. Anchor points for safety ropes are to be provided above ladders, especially where the drop in height is greater than 2.5 m.
- vi. Ladders are not acceptable for access into dry wells. The stairway width must be per building code. Fiberglass stairways are acceptable. Stairs are not required for prepackaged fiberglass lift stations.
- vii. The preferred hatch size is 1.0 m x 1.0 m. Any hatch on platforms shall be hinged and have locking mechanisms to prevent the grating/hatch from falling on workers. Any penetration through a platform requires fall protection guardrail/mangate, or travel restraint (not preferred).

- viii. All external access hatches shall be protected by bollard to prevent vehicle passing over.
- ix. Doors and access hatches shall have suitable locking devices in accordance with EPCOR Drainage Services electronic programmable locking standards. All external access hatches shall be pad-lockable and all padlocks supplied keyed to suit EPCOR Drainage Services security key system.
- x. For all entry hatches, non-protruding extension ladders are to be provided, which must be located far enough away from the walls to be able to be pulled up through the access opening and extended to a height of at least 1.0 m above the roof. Guard rails are a requirement around access openings. Chains are prohibited.
- xi. Access hatches covers for all roof openings to wet or dry wells must be sealed or have sufficient overhang to prevent rainwater inflow. Odour tight aluminium hatch covers should be used.
- xii. Floors and platforms shall be provided to allow access to all components to facilitate maintenance, repair, removal and replacement tasks. Such floors and platforms shall not obstruct access to any other component.

#### 2.13.3 Lighting

- i. Adequate lighting shall be provided for the entire facility. The light fixtures shall be of LED type. Emergency backup lighting shall be provided.
- ii. Wet well lighting should be arranged to be indirect (from outside of the well) and maintainable without entering the wet well whenever feasible.
- iii. Exterior lights are to be provided to illuminate all building entrance areas, entrance hatches and outside equipment access locations.

#### 2.13.4 Ventilation

- i. Forced mechanical ventilation is required at all wastewater facilities. Suitable equipment shall be installed to provide for continuous ventilation at a rate of 6 air changes per hour (at low water level) in each of the wet well and dry well areas. Completely separate systems are required for each well and there must be no interconnection between the wet well and dry well ventilation systems.
- ii. Fresh air, heated and thermostatically controlled, shall be forced into each area at a point 150 mm above the floor in dry wells and 150 mm above the high water level in wet wells and exhausted at higher levels. In pits over 4.5 m deep, multiple inlets and outlets are desirable.
- iii. Subject to the approval of AEP, provisions for connection of portable ventilation equipment may be included as an alternative to continuous ventilation for the wet well only. The Engineer will supply details of the connection requirement on request.
- iv. Consideration should be given to provision of an automatic control to increase ventilation rates to 20 to 30 air changes per hour, interlocked to turn on with light switches or door switches, in addition to the continuous ventilation requirements.
- v. Provision shall be made to detect and actuate an alarm if the ventilation system should fail. A local alarm indicator, noticeable prior to station entry but not to be noticeable to the public, is required. A volume controllable buzzer and red beacon on the inside of a building, visible as soon as the doors open, is acceptable. Provision shall be made for transmission of the alarm through the SCADA system to the EPCOR Drainage Services' dispatch office.
- vi. Provision is to be made for ventilation of wet wells using portable ventilation equipment. This provision is to consist of a 200 mm diameter standpipe extending from inside the wet well to a flanged connection on the exterior of the facility. The end of the standpipe is to be located so as to permit discharge of air through the standpipe to a point 150 mm above the normal high operating level of the wet well.

#### 2.13.5 Balancing Report

For stations with new or refitted ventilation systems, a balancing report is required, signed by a professional engineer, indicating measured ventilation flows and actual air change rates. This is to be

forwarded by the Consultant to EPCOR Drainage Services and posted in the station.

## 2.14 Heating

Use high-efficiency furnaces or boilers and provide heat recovery units to recover waste heat from exhausted air. Design the entire facility for energy conservation.

### 2.14.1 Water Supply

A potable water supply with sufficient length of hose is to be provided, to supply 0.4 L/s at 275 kPa for cleaning floors, equipment and pumps. There shall be no physical connection that might under any condition cause contamination of the potable water supply. Backflow prevention and cross-connection control must comply with current Provincial and the City of Edmonton plumbing regulations. Backflow preventers shall be the reduced pressure principal type installed 1.0 m above grade.

### 2.14.2 Provisions for Operating Personnel

- i. Washroom Facilities: A partitioned washroom and lavatory are to be provided, including:
  - a toilet;
  - a large sink;
  - a washroom exhaust fan interlocked with the light switch;
  - floor drains with positive trapping;
  - mirror;
  - soap dispenser;
  - towel dispenser.
- ii. Office Space: An office space and work area is to be provided, including the following items:
  - single pedestal desk and swivel-tilt arm chair;
  - floor mat;
  - waste receptacles;
  - fire extinguishers;
  - spare parts storage.

## 2.15 Sump Pump

- i. Dry wells must be equipped with a sump and sump pump to deal with leakage or seepage. Sump pumps greater than 5 hp must be approved by EPCOR Drainage Services. The sump pump is to discharge to the wet well, at a point above the maximum high water level. A check valve and isolation valve downstream of the check valve shall be provided in the discharge pipe to preclude backflow of wastewater into the sump.
- ii. Sump pumps should be of the appropriate size and capacity to handle common solids and must be capable of draining the well that it is designed for. The connection from sump to wet well must also be high enough to allow pump out of the dry well into the wet well for the condition where the dry well is flooded.
- iii. A sump pump must either line up with the main dry well hoisting system for safe lifting or must include its own separate lifting system and trolley.

## 2.16 Site Requirements

### 2.16.1 Vehicle Access

A 4.5 m (minimum) wide paved road is to be provided into the site, with extensions as appropriate to provide maintenance vehicle access to electrical transformers and for removal or delivery of other station equipment. Space should also be provided for parking of maintenance staff and service vehicles and to allow turning of vehicles if necessary to exit the site without backing onto heavily

trafficked roads. Dropped curbs are required where it is necessary to cross a curb line.

2.16.2 Fencing

All above ground pumping stations shall be fenced. The fence shall have an opening gate for entry of vehicles and equipment. The gate shall be pad-lockable to prevent unauthorized entry. Fences shall typically be zinc coated industrial grade steel chain link security type, of 1.83 m overall height complete with three-strand barbed wire overhang. Architectural fences providing a similar level of security may be considered where dictated by aesthetic considerations. Fencing must be durable and maintenance free. All padlocks shall be supplied, keyed to suit EPCOR Drainage Services security key system.

2.16.3 Site Grading

The pumping station site grading shall meet lot grading design requirements. The pumping station site shall be adequately graded so that it drains freely away from the facility and no ponding of water occurs adjacent to buildings, entrances or around electrical transformers. Site elevations shall be established such that the facility is not subject to flooding due to runoff flows or ponding under any conditions of rainfall or runoff from snowmelt.

2.16.4 Service Connection

A storm service connection is required for all pump station sites. Sanitary pump station building (lowest building opening) must be at or above the freeboard level adjacent to SWMF.

2.16.5 Landscaping and Aesthetic Considerations

At the minimum, pumping station sites shall be landscaped with grass or provided with a low maintenance ground cover material that effectively inhibits growth of weeds. Where the proximity to residential areas or other public land uses dictates a need for additional landscaping measures to conceal the facility, to make it blend into the surroundings or to enhance its appearance, these must be part of the facility design and construction. These measures may include appropriate planting of trees and shrubbery or architectural treatments of structures.

2.16.6 Signage

Exterior identification signs shall be installed prior to construction completion certificate (CCC) and must include the station number and phone number. Developer and/or Consulting engineer's contact information shall be on the signage until CCC is issued (refer to **Figure 2.3**).



**Figure 2.3: Station Identification Sign Example**

**2.17 Operation and Maintenance Manual**

2.17.1 As part of the responsibility for the design of a wastewater pumping station, the design engineer shall prepare and provide an Operation and Maintenance (O&M) Manual for the facility.

2.17.2 One hardcopy of the O&M manual is to be provided in a piano hinged binder with 65 mm spine bound heavy weight fabricord as well as a searchable and organized PDF version following the standard requirements for the O&M manual. Draft O&M manual is to be provided prior to CCC inspection and the final version of the O&M manual is to be provided prior to approval of a CCC. If any material changes are done between CCC and final acceptance certificate (FAC), updated O&M manual shall be delivered as soon as practicable after material changes and before FAC application.

- 2.17.3 The O&M manual shall include complete equipment manufacturers' operation, maintenance, service and repair instructions and complete workshop manuals and parts lists for all mechanical and electrical equipment, including all control diagrams and schematics with wires individually numbered and identified. Each set shall be firmly bound in a hard-covered binder and include test results and calibration of all equipment from commissioning and testing conducted by professional engineers for the Developer prior to application for a CCC. Refer to Section 3.1.4 - Vol. 3-05: Drawing Requirements, Approvals and Asset Acceptance/Transfer.
- 2.17.4 The O&M manual shall include a description of the nature and function of the station:
- Name and address and name of developer;
  - Type of effluent;
  - Location and size of contributing area in terms of the design number of lots and industrial and commercial effluent flows and gross storm drainage area;
  - Statement of the control sequence identifying the controlled equipment and set point values including any equations or tables of values from which set points are derived, including operation of backup facilities such as emergency generators and storage tanks;
  - List all monitored quantities, statuses and alarms and their set point values;
  - Instrument calibration and device settings as detailed in **Appendix A**.
- 2.17.5 The O&M manual shall include a simplified schematic and description for quick reference (a “user-friendly drawing”) indicating operations modes, bypass considerations, basin area, etc. (see Example Drawings 188 in **Appendix A**)

## 2.18 Requirements for Activated Carbon Odour Control Units (OCU) in Pump Stations

### 2.18.1 General

The activated carbon adsorption units should be capable of continuously treating odorous air at 100% relative humidity at air exchange rates for wet wells. The activated carbon adsorption system should be supplied complete with all supporting equipment and documentation required for system operation. The activated carbon media should also be supplied.

The activated carbon filter system should generally consist of an inlet isolation valve, pre-filter, heater, activated carbon housing and activated carbon media, extraction fan(s), discharge stack, control equipment panel, and monitoring equipment.

The minimum activated carbon design bed life should be approximately 24 months. The bed life is defined as the length of time between replacements of the activated carbon media based on breakthrough of gas. The Contractor should submit calculations verifying the amount of carbon to meet the carbon bed life specified.

- OCU's should be built above ground to avoid potential complications associated with high levels of hydrogen sulphide, utilities, space constraints, confined space entry and flooding:
  - Have enough room to inspect around the unit;
  - Be heated in a heated location;
  - Well-constructed.
- Be safe to construct, operate, maintain and decommission;
- Provide reliable and effective odour removal;
- Have a minimum of 20 years' service life;
- Comply with all relevant statutory and regulatory requirements, standards, code of practices and municipal design standards;
- Not cause interruption to the normal operation of the pump station;
- Be capable of automatic operation via connection to EPCOR Supervisory Control and Data

Acquisition (SCADA) for Drainage Facilities;

- All electrical and mechanical systems should be above ground;
- Adequate access should be provided to allow all expected operational and maintenance activities to be carried out in a safe and efficient manner;
- Allow easy installation and removal of equipment by lifting devices;
- Noise level should follow the City of Edmonton, Community Standards Bylaw 14600.

#### 2.18.2 Pre-filter(s)

One easily removable and cleanable pre-filter assembly should be installed downstream of the inlet isolation valve and upstream of all other OCU equipment. The pre-filter should be designed to remove particulate matter and should have a removal efficiency of 96% based and of corrosion resistant construction materials. The pre-filter design should be sufficient to provide consistent flow to the unit for a period of approximately 6 weeks between cleaning events. The pre-filter(s) should be mounted in a frame and be constructed to prevent bypassing of the filter by inlet air. One spare set of filter(s) should be supplied. The design of the pre-filter should facilitate easy removal of the pre-filter for cleaning/replacement.

#### 2.18.3 In-line Duct Heating

Should be provided on the inlet side of the carbon media adsorption unit. The capacity of the heater should be sufficient to reduce the relative humidity to less than 70% for the design inlet airflow with a relative humidity of 100% at 20°C. The in-line heater should not operate unless the fan is running and airflow through the inlet ducting is ensured. Temperature measurement and indicators should be provided on the inlet and outlet of the heater.

#### 2.18.4 Adsorption Unit

The activated carbon vessel, internal components, and structural components should be corrosion resistant material. The minimum activated carbon bed life should be approximately 24 months. The carbon adsorption unit and associated ductwork should be designed to minimize pressure drop, prevent any by-pass of gas flow, and provide easy access for maintenance.

#### 2.18.5 Monitoring

Permanent sampling ports should be provided on the carbon adsorption unit. Media Bed Monitor is required for all carbon beds only.

Sample ports for air sampling on the discharge side according to stack survey requirement

#### 2.18.6 Control System

The activated carbon system should be designed for unmanned operation fully automated with allowance for manual operation. The activated carbon system unit should be installed with the following instrumentation and monitors as a minimum:

- Differential pressure transmitters should be provided to measure the head loss across both the pre-filters and the OCU media bed connected to EPCOR SCADA;
- Air flow monitoring (flow switch after fan) – interlocked to shut down the heater and connected to the EPCOR SCADA;
- Temperature transmitters before and after the heater – connected to EPCOR SCADA;
- Hydrogen Sulphide meters should be supplied to monitor the inlet and outlet OCU performance. Connected to EPCOR SCADA.

#### 2.18.7 Adsorptive Media

The Contractor should include information including details and price of the activated carbon intended to be supplied in the concept design for review.

- The adsorptive media should be either impregnated activated carbon or other similar media that



is predominantly an activated carbon material, chemically treated to adsorb the constituent gases from the collected airstream.

- The depth of media should be such that the minimum contact time for the airstream in the OCU is at least 2.0 seconds at maximum design airflow without exceeding the manufacturer recommended gas velocity through the activated carbon (typically maximum 25-33 cm/s). The adsorptive media should be evenly distributed in the bed so that no bypassing or short circuiting of foul air occurs within the OCU.

#### 2.18.8 Media Chamber Access

Separate and easily accessible compartments/hatches for each type of media are required to facilitate monitoring and maintenance for crews, service trucks and vector trucks. The chambers must be independent of one another for direct removal/replacement of media. The hatches should be lockable and of sufficient size to allow both removal of carbon by suction hose.

Outlet concentration as measured at the exit of the OCU or vent stack: Hydrogen Sulphide (H<sub>2</sub>S) ≤ 0.03 ppm.

#### 2.18.9 Inlet Isolation Valve

An easily operated positive shut off isolation valve should be provided on the extraction ductwork to the OCU. This valve is to provide a gas tight isolation of the OCU from the inlet gases for the purpose of carrying out maintenance activities. For treatment of wet wells, bypass ventilation ducting should be installed so that the treatment unit can be bypassed.

#### 2.18.10 Drain

The OCU should have gravity drains to remove condensate from all parts of the unit. The material of construction should be sulphuric acid resistant. Drainage points must be supplied to prevent any condensate from collecting in the OCU.

#### 2.18.11 Operating and Maintenance Manual

An O&M manual should be provided for the OCU. An acceptable O&M manual is considered a key requirement for successful handover. It should be provided in both paper form and electronic form

The manual should include, but not limited to:

- Overview of the OCU conceptual design;
- Detailed description of the unit and its components, process, and performance criteria;
- Detailed P&IDs, complete list of all equipment items (including electrical items);
- Detailed information for each supplied piece of equipment (Manufacturer, supplier, model number);
- A list of suppliers and their current contact details;
- Standard operating instructions covering all routine work requirements (system start up, shut down, routine monitoring, maintenance, inspections, changing of media);
- Process optimization and troubleshooting guide;
- The PLC functional description, Input / Output listings, electronic copies of PLC programs, details of the programming software used (including version details) and where it can be obtained;
- Reference listing of all monitoring and alarm signals both locally and transmitted to EPCOR SCADA
- Reference listing of all interlocks and system timers (their values, allowable ranges and where these are set);
- List of any recommended spares to be held;
- Instructions on storage, loading/unloading, and SDS of treatment media

- Complete program settings for all programmable equipment (for example, Differential Pressure Transmitters);
- Basic description of OCU system, including process flow description;
- Drawings with the proposed layout complete with key dimensions, showing ductwork and access;
- List of any special tools and lifting devices.

### 2.19 EPCOR Chemical Dosing Requirements

Everything needs to comply with the relevant electrical/building/OH&S codes requirements. All stations with chemical treatment are required to have the following:

#### 2.19.1 Pump Skid

- 1 duty and 1 spare diaphragm pump;
- Pumps to be selected to allow varying the dosing rate;
- Discharge hose for the pump is to deposit in wet well;
- PLC controllable.

#### 2.19.2 Tanks (located inside the building)

- Must have enough room to inspect around and top of tanks;
- Must provide 60 days of storage;
- Provide high level overflow;
- Have visual verification of level gauge;
- Continuous level monitoring using SCADA with a local display;
  - Include a high and low level alarm for liquid level in the tank
- Temperature control building. The optimal temperature for most chemicals is 20°C. Include the low/high temperature alarm to SCADA;
- External chemical fill location with tank level indicator and alarm.

#### 2.19.3 Safety

- Must have secondary spill containment. Ideally the tank and pump have separate containment area;
- Chemical safety data sheets (MSDS);
- Eye-wash station and safety shower designed and located according to ANSI Z358.1.

#### 2.19.4 O&M manual for chemical dosing system and all the equipment

## 3.0 DESIGN OF SEWAGE FORCEMAINS

### 3.1 Forcemain Size Considerations

The design of a sewage forcemain is to include study of the comparative costs of construction and long-term operation for alternative sizes. There are, however, practical limitations to the size options which may be considered, as flow velocities are required to exceed certain minimum values to prevent slime growth within the forcemain and to ensure solids are not deposited within the forcemain. It is also necessary to minimize the residence time of sewage within pumping station wet wells and forcemains to avoid anaerobic fermentation and the resultant production of odorous, hazardous and corrosive gases such as hydrogen sulphide (H<sub>2</sub>S).

### 3.2 Flow Velocity Limits

- 3.2.1 To prevent slime growth on the pipe walls of the forcemain and to transport solids, the minimum velocity of flow in the pipe should exceed the velocity determined by:

$$V = -0.3 \log \frac{0.1}{D}$$

where,  $V$  = velocity in m/s

$D$  = pipe internal diameter in mm

- 3.2.2 Optimum design velocities, in the range of 0.9 to 1.5 m/s, are recommended, considering both operating costs and prevention of solids accumulation. When the forcemain grade profile includes steep slopes or vertical sections, the minimum design velocity should be increased by an order of 50%. Where design flow velocities in buried forcemains exceed 3.0 m/s, any special provisions required to ensure stability of the forcemain shall be identified and incorporated in the design. A maximum flow velocity of 3.5 m/s is recommended.

### 3.3 Design Pressures

The pressure design for forcemains shall consider normal static and dynamic operating pressures, the potential conditions that may occur due to outlet surcharge or blockages and transient pressure (water hammer) effects. A transient pressure analysis is required to determine if protection is required and appropriate provisions are to be incorporated into the pumping system design.

### 3.4 Surge Protection Devices

Where necessary, surge relief valves shall be designed with a suitable discharge location and be located with a suitable method of access. Surge relief valves that regulate with external springs or counterweights and dashpots are preferred to valves regulated with pilot pressure piping systems, for sanitary wastewater and liquids with substantial solids content. Rupture discs shall not be used.

### 3.5 Slope

All forcemains shall be sloped sufficiently to promote the discharge of air during filling and to permit the forcemain to be drained. Forcemains shall not be installed at zero slope.

### 3.6 Alignment

Forcemains should have a straight alignment wherever possible. The use of 90° bends in forcemains is to be avoided. A series of 45° or smaller deflection bends are to be used where extreme direction changes are required.

### 3.7 Air Release

Automatic air release valves shall be provided at all relative high points along the forcemain. The need for air release valves should be minimized by establishing the grade profile to eliminate summits. Air release valves are to be installed in waterproof concrete access chambers, insulated to prevent freezing and with provisions for drainage.

### 3.8 Blowoff Valves

A valve for blowoff and drainage of the forcemain is to be provided at each low point.

### 3.9 Vacuum Relief

Provision for vacuum relief shall be made as necessary where forcemains are proposed to drain by gravity between pumping cycles.

### 3.10 Forcemain Outlet

- 3.10.1 The forcemain should enter the receiving manhole horizontally at an invert elevation no more than 300 mm above the flow line of the receiving sewer. A smooth flow transition to the gravity sewer is to be designed to minimize turbulence at the point of discharge.
- 3.10.2 Inert materials or protective coatings shall be used for areas subject to sulphide attack.

### **3.11 Design Documentation on Engineering Drawings**

The Engineering Drawings shall include "system head" curves for each forcemain, considering the wet well water level at its lowest and highest points and for each different pump operation combinations possible. The plans shall include a notation of the design basis, which shall specify the design friction coefficients, equivalent hydraulic length and design operating conditions.

### **3.12 Requirements for Locating Forcemains**

To facilitate location, a tracing wire shall be placed along all forcemains at the time of construction. The wire shall be terminated in a labelled electrical box at the pump station (or appropriate secure location) and looped in any valve chambers and blow-off chambers to allow for connection of an electronic locator at intervals of not greater than every 300 m along the length of the forcemain. If a chamber is not available to provide this interval, the wire shall be looped into a cast iron valve box set at grade level. Locator wire shall be stranded 12-gauge copper with insulation for direct burial. Underground splice connections shall be minimized and shall be rated for direct burial service. Prior to acceptance of the forcemain, a continuity check shall be conducted to verify that the wire has not been broken during installation.

### **3.13 Requirements for Forcemain Inspection and Cleaning**

A pig launch port is to be provided at the pump station for cleaning and inspection of the forcemain. The intent of this provision is to allow cleaning using conventional pigs and inspection using smart pigs, televising or other equipment without significant pipe dis-assembly.



## Appendix A

# **Design Guidelines for Electrical and Control Systems for Wastewater Pumping Stations**



---

**TABLE OF CONTENTS**

**1.0 ELECTRICAL DESIGN PHILOSOPHY .....1**

1.1 Basic Level-Of-Service Objectives .....1

1.2 Supervisory Control and Data Acquisition (SCADA) System Overview.....1

1.3 Control .....1

1.4 Monitoring .....2

1.5 Maintenance and Operation .....4

1.6 Lock Out Standard.....5

**2.0 DESIGN GUIDELINES .....5**

2.1 Electrical Power Supply System .....5

2.2 Telephone Service.....6

2.3 Data Logger .....6

2.4 SCADA System .....7

2.5 Standby Systems.....10

2.6 Lighting .....12

2.7 General Construction and Wiring .....13

2.8 Pump Station Control.....15

2.9 Level Controllers/Float Switches .....21

2.10 Flow Meter .....22

2.11 Heating and Ventilation .....23

2.12 Renovation of Existing Facilities .....24

2.13 Miscellaneous Systems .....24

**LIST OF STANDARD ELECTRICAL DRAWINGS .....25**

**USER-FRIENDLY DRAWING .....25**

## 1.0 ELECTRICAL DESIGN PHILOSOPHY

### 1.1 Basic Level-Of-Service Objectives

1.1.1 The electrical design for control, monitoring and provision of backup systems at mechanical drainage facilities shall be based on producing a high degree of reliability in the maintenance of:

- Public safety from flooding of roadways.
- Public health and property damage from flooding of property.
- Public health and protection of the natural environment from release of pollutants to watercourses.
- Safety of the public and operators from hazards at facilities.

### 1.2 Supervisory Control and Data Acquisition (SCADA) System Overview

1.2.1 A SCADA system is utilized to remotely monitor drainage sites such as pump stations, storage facilities, monitoring facilities and gate controls located throughout the City. The SCADA runs on GE iFIX software to collect and display current status of all field devices, control selected field devices, report and process alarms, and collect historical information. Status changes and alarms are reported to SCADA Servers as they occur through either polling or reporting by exception on a case by case basis. The method of communication can be confirmed with EPCOR Drainage Services.

1.2.2 All new facilities require status monitoring, data logging, remote control capability and alarming of all automated processes and devices to a level at which proper operation, in accordance with the stated intentions of their design, can be remotely confirmed.

1.2.3 At the present time SCADA controls are enabled on selected remote locations to control field devices. The requirement and priority remote control points, if required, shall be reviewed with EPCOR Drainage Services prior to implementation.

1.2.4 Monitoring data is sent from the field sites to the SCADA servers using Rogers Communications wireless network. The iFIX SCADA server updates its database values, generates alarms, creates historical data, and accepts requests for the data from view nodes or SCADA clients located throughout the City.

### 1.3 Control

1.3.1 Automatic control of pumps shall be performed using a Programmable Logic Controller (PLC) and level sensors/controllers. PLC types are described in Section **2.8.5**. Level sensors/controllers are described in Section **2.9**. Control of other field devices can also be implemented using Auxiliary Digital Outputs of field devices in instances where the PLC outputs can't be utilized, this needs to be assessed on a case by case basis and reviewed by EPCOR Drainage Services.

1.3.2 Network communication (Ethernet/IP or Modbus RTU) is preferred between the level controller and PLC, and Ethernet/IP from the PLC to SCADA (In some cases DF1 is used, confirm with EPCOR Drainage Services), in addition to the hardwired signal. For pump station applications, the level controller shall provide pump control backup in the event of a PLC failure. A PLC fail output relay shall be used to provide the transfer of pump control from PLC to level controller upon PLC failure. Pump start/stop relays shall be provided and programming shall be provided in the level controller, as required.

1.3.3 Manual pump control shall be provided by a "hand/off/auto" selector. This selector shall directly energize and de-energize the motor starter relay circuit without relying on any additional controller.

1.3.4 Controller settings shall be made with consideration of the hydraulic effects and long-term reliability of the facility. Examples of such settings include:

- If a pump controller is configured for lead and lag operation, the pump stop set points shall be different for the lead and lag pump, so that they do not switch off simultaneously, thereby reducing deleterious, hydraulic surge effects in the pipe work.
- Sufficient capacity shall be provided in the wet well between the lead and lag pump stop elevations to allow the lag pump to stop before the water surface falls to the lead pump stop elevation.

- Assignment of the lead or duty pump shall alternate automatically after each cycle so as to tend to equalize the running time of each pump.
  - Careful consideration shall be given to any fail-safe setting in the pump controller. Potential causes of failsafe conditions shall be identified and the setting chosen to produce the least damaging effects consistent with the basic levels of service stated in Section 1.1 and damaging effects to equipment such as cavitation or overheating of pumps. The three fail-safe options available in the Siemens MultiRanger controller are:
    1. Fail safe high: switch on all pumps and high alarms
    2. Fail safe low: switch off all pumps and low alarms
    3. Hold last known settings
- 1.3.5 Where pumps and other devices are controlled by signals transmitted over telecommunications systems from sensors at remote locations, the signals shall be transmitted as digital data with modems or other approved means of transmitting digital data. Communications via Roger's cellular network is preferred when there is no radio line of sight between two field stations. Hard links over short distances, leased lines or other wireless technology may be considered where cellular signal is not possible and upon approval of EPCOR Drainage Services.
- 1.3.6 Where the forcemain and pipe work is of sufficient strength to withstand the maximum hydraulic surge pressures, but may be susceptible to long-term deleterious effects from hydraulic surge pressures and slamming of check valves, the preferred method of minimizing such effects is by means of solid state, soft start or variable speed, motor controllers on pumps. Such selected motor controllers shall be specifically designed to steadily vary the driving torque produced by pump motors during starting and stopping. In cases where the pipe work and forcemain do not have sufficient strength to withstand hydraulic surge effects, the method of hydraulic surge protection shall be independent of the electricity supply.
- 1.3.7 Where pump motors are stopped by gradually reducing the speed over an extended period, control level settings shall allow sufficient capacity in the wet well to avoid drawing the water level below the pump suction after the stop sequence has been initiated to prevent damage to the pumps.
- 1.3.8 Where it is desirable to vary the pump discharges by varying the speed of the pumps, the preferred method is to use pulse width modulated variable frequency drives. In such cases consideration shall be given to avoiding deleterious surges caused by rapid speed changes and collection of solids in pipe work caused by protracted operation at low speeds.

## 1.4 Monitoring

- 1.4.1 The critical aspects of the operation of the facility shall be identified and monitored by means of backup circuits that work with the greatest degree of independence possible. Typical examples include the following sensors connected directly to the PLC so they will remain powered by the uninterruptible power supply (UPS) in the event of main electricity supply failure. These alarm circuits shall not be fitted with hardwired test switches or soft switches in the HMI that could disable the circuit:
- Float switch level sensor to sense high and low water level (separate from the ultrasonic sensor high and low water signal), and to start one designated pump when water level is high, if no pump was running. Sanitary pump station with emergency overflow float switch level sensor to sense the onset of overflow. Storm pump station for draining a road, float switch level sensor to sense the onset of flooding of the road.
  - Door-mounted, limit switch to sense an intruder. Door switches shall be on the main entrance door of buildings, doors of pole-mounted or freestanding electrical cabinets, or access hatches for facilities with all construction below ground. In situations where a panel is used, have a tamper switch and feed it as a digital input into the PLC such that an intrusion alarm is generated by the PLC when the panels are tampered.
  - Smoke detector to sense fire. Smoke detector shall be near electrical panel to sense fire inside buildings, or inside freestanding electrical cabinets.



- Main electricity supply sensor with delay programmed at one minute in the PLC.
- All Hand/Off/Auto switches for the main pumps should be set in a default “Off” position (excludes dry well sump pumps and non-hazardous area ventilation fans).
- Pump stations with a dry well: float switch to sense water depth 150 mm above the dry well floor.
- Emergency generator set failed.
- Applied torque from an electric actuator in terms of torque and percentage of capacity.
- Carbon monoxide (CO) and LEL detector to sense high concentration of CO and hydrocarbon in the generator room.
- All discrete inputs to the PLC should be filtered with de-bouncing logics in the PLC program. As each input is different

1.4.2 Non-critical aspects of the operation of facilities are those for which a backup operation system is available or which are unlikely to lead to an immediate or imminent failure to meet the basic levels of service described in Section 1.1. Typical examples include the following sensors connected to the PLC, to reduce provision for relays:

- When designated level settings for pump start are reached, the PLC relay outputs are energized. These outputs are utilized in each pump starter control circuit. A motor current signal from the pump starter overload module or current sensor, back to the PLC, shall initiate a time delay programmed into the PLC and alarm after 20 seconds, when a pump fails in the demand mode. This will transmit an alarm signal via the PLC.
- Differential pressure - type switch to sense air flow failure in the dry well ventilator.
- Pump winding temperature via Flygt Mini CAS II (or equivalent alternative upon approval from EPCOR Drainage Services) in the main control panel. This alarm signal shall disable the pump. Where more than one temperature sensor is provided in each pump, each sensor shall produce a separate signal.
- Liquid ingress shall disable pump if the pump is over 20 hp.
- For larger pumps use Flygt - MAS 711 (or equivalent alternative upon approval from EPCOR Drainage Services) monitoring system for monitoring winding temperature, liquid ingress, vibration, and pump bearing temperatures. Excessive temperature conditions shall disable the pump.
- Pump failed:
  - Overload for each pump motor.
  - Phase loss for each pump motor.
  - Phase imbalance for each pump motor.
  - Under load for each pump motor.
  - Ground fault for each pump motor.
  - Jam for each pump motor.
  - Stall for each pump motor.
  - Pump failed to start
  - Loss of communications between motor controller and programmable logic controller for each pump motor.
- Pump motor stator leaking – for each pump
- Pump lubricant chamber leaking – for each pump
- Motor current for each pump motor.

- Temperature Transducer to sense building or control panel temperature.
- Pump stations with an emergency storage tank: ultrasonic or hydrostatic transducer to sense the onset of tank filling, storage utilized in terms of volume and percentage of capacity, and tank full.
- Emergency generator set:
  - Engine battery charge low.
  - Running.
  - Failed - common trouble.
  - Other alarms as applicable to the specific model of the generator
- Valve or Gate position and failure.
- Transfer Switch position and trouble.
- Discharge flow from the station, if EPCOR Drainage Services requires a flow meter.
- Flow totalizer, if EPCOR Drainage Services requires a flow meter.
- For Uninterruptible Power Supplies that provide power to mechanical equipment:
  - UPS power supply battery charge low.
  - UPS fault: unable to produce alternating current.
  - UPS charge as percentage of capacity.
  - Other alarms as applicable to the specific model of the UPS

## 1.5 Maintenance and Operation

- 1.5.1 A written description of all modes of operation of the facility shall be included as the first section of the operation and maintenance (O&M) manual, illustrating the control narrative. The description shall include system behavior in all foreseeable circumstances, together with the governing criteria for each mode of operation. Criteria shall include control elevations and discharges, as applicable, at all sensors for pumps, and automatic valves and gates, and normal valve or gate positions and pump discharges under specified conditions. State also critical conditions and relevant values, such as liquid levels, that are monitored such as “storage full”, “overflow” etc. Include any governing, look-up tables, equations, and conditions applied by means of feed-back loops etc.
- 1.5.2 All failure conditions for which allowance has been made in the control system shall be listed together with the programmed response of the control system to each condition.
- 1.5.3 The manual shall include a table of all monitored conditions and their respective terminal number connections to the PLC.
- 1.5.4 The O&M manual shall include a table of the programmable settings and values programmed for each programmable device, such as controllers, motor drives, overload relays, variable frequency drives (VFD) and monitoring instruments. State the range and span settings of instruments. For instruments that measure position, such as water level, state the location of the position datum relative to the range. For signals used to transmit the values of physical effects, state the calibration or scaling factors used to produce the displayed values: this may be done by reference to specific lines in a printout of the programmable controller logic included in the O&M manual.
- 1.5.5 The manual shall include copies of all commissioning reports including results, dates of commissioning and names of witnesses.
- 1.5.6 The manual shall include a record of the manufacturer’s serial numbers of all equipment and control devices.
- 1.5.7 Electronic copies of all backup files shall be provided, such as:
- HMI program files.

- Complete PLC program files including comments, descriptors, add-on profile (AOP) and electronic data sheet (EDS) files for all equipment supplied with Ethernet/IP communication.
- The non-contact ultrasonic or radar transducers shall have available software to backup parameter and view echo profiles.
- VFD setup files.

## 1.6 Lock Out Standard

- 1.6.1 Mechanical and electrical equipment shall be capable of Lockout in accordance to applicable acts and regulations.

## 2.0 DESIGN GUIDELINES

### 2.1 Electrical Power Supply System

#### 2.1.1 General Electrical Requirements

- All electrical systems and wiring shall be in accordance with the latest requirements of the Canadian Electrical Code, Electrical Protection Branch, Alberta Department of Municipal Affairs and Housing amendments, and the local inspection authority. A copy of the inspection acceptance report shall be provided to EPCOR Drainage Services.
- All electrical systems shall be in accordance with the requirements and construction methods as outlined in these Design Guidelines and as directed by EPCOR Drainage Services.
- Electrical equipment such as switchboards, panel boards, industrial control panels, meter socket enclosures, and motor control centers (MCC) that are likely to require examination, adjustment, servicing or maintenance while energized shall be field marked to warn persons of potential electric shock and arc flash hazards.

#### 2.1.2 Power Supply

- When required, provide underground primary duct with pull cord from the Utility Company switching cubicle to transformer pad primary. Maintain 3.0 m minimum clearance from all other underground services, pipes, manholes or buildings.
- Provide for power service feeder from transformer secondary, underground to main power panel, unless specifically approved otherwise by EPCOR Drainage Services.
- 600 volt, 3-phase, 3-wire power service is preferred to all wastewater pumping facilities.
- In order to accommodate for future capacity upgrade, the service entrance conduit(s) shall be sized to accommodate service conductors of double the required initial load or spare conduits of equal size
- A coordinated main service, standby power transfer and motor control center is preferred to loose wall mounted equipment.
- Phase rotation shall be clockwise, and shall be labelled accordingly.
- Where a 600 volt, 3-phase mains electricity supply is not readily available and cannot be economically provided at the site of a pump station before it is commissioned, and approval is obtained from EPCOR Drainage Services, converting the available electricity supply to 600 volt 3-phase shall be achieved utilizing VFDs.
- The preferred means of converting single phase to three-phase power and electrical control of motor speed is by a VFD from Allen-Bradley PowerFlex ranges of variable frequency drives. Adequate cooling and ventilation shall be provided for such devices. Outdoor enclosures for such devices shall be designed to maintain them within the maximum and minimum operating temperatures specified by the manufacturer. Short circuit protection for drives shall be provided in the form of high speed fuses type HSJ unless protection is provided integral to the drive.
- Install step-down transformer from 600 volt to 120/240 volt, 1-phase, 3-wire lighting panel for miscellaneous lighting and power requirements.

- Power factor correction is required only where billing will be on the basis of KVA demand and electric motors 7½ hp and larger are used. The power factor of any pump motor shall not be less than 0.8 and in general shall be as close to 0.92 as economically possible.
- The desirability of power factor correction shall be established by consultation with the Utility Company on the power supply conditions at the proposed site. The designer shall produce estimates of the cost of providing power factor correction capacitors and the associated saving on energy charges.
- If power factor correction capacitors are used in conjunction with solid state soft start devices, the soft starter shall be supplied with a separate auxiliary contactor to be wired to the line side of the soft starter to switch the power factor capacitors. The auxiliary contactor is to be energized when the soft starter signals motor is at full speed. At no time must the power factor capacitor be left connected to the supply bus without its motor running.

### 2.1.3 Main Panel Assembly

- Where the main panel assembly is selected as a free standing modular unit such as a motor control center (MCC), it shall be mounted on a raised concrete plinth.
- MCC shall have shipping splits in groups of two, when required, such that they can pass through doors when the MCC is turned on its side.
- If large transformers are installed in MCCs and they require tipping, consideration should be made for removal of the transformer.
- Where the main panel assembly consists of wall-mounted equipment, all components shall be mounted on a painted one-piece, good-one-side, fir plywood backboard, securely attached to building wall. If the wall does not contain thermal insulation, insulation shall be provided between the backboard and the wall.
- The main panel assembly shall be fabricated of steel and sized as noted in details on the drawings.
- On power services at 200 Amp and below, the meter socket shall be located on the building exterior, unless otherwise agreed with the utility company.
- The main power disconnect shall be located on the interior of the building.
- Exterior meter sockets shall be protected by a custom fabricated, heavy-gauge galvanized steel cage to reduce vandalism.

### 2.1.4 Grounding

- Grounding system to consist of copper clad steel ground rods 20mm diameter by 3000 mm long as a minimum and interconnecting ground conductor. All ground terminations shall be compression type. Provide additional grounding to building structure, motor starter for each pump, major mechanical equipment, building water main ahead of shut-off valve, and gas line.

### 2.1.5 Power Meters

- Main Power Supply Meters - Provision shall be made for a 3-phase voltmeter, either displaying or with means of selecting A-B-C phases on the main power supply line.
- Pump Power Supply Meter - In each starter enclosure, an elapsed time meter and an ammeter on one phase shall be provided for each motor. The meters shall be installed on the covers of the respective motor's combination magnetic starters.

## 2.2 Telephone Service

### 2.2.1 Telephone Service (if required)

- Co-ordinate with EPCOR Drainage Services authorized representative, on an individual project basis, to determine if a telephone service is required.

## 2.3 Data Logger

- The requirement for a data logger will be specified by EPCOR Drainage Services.

- The data logger shall be located adjacent to PLC panel.
- The data logger shall be Campbell (CR800 or equivalent latest model - consult with EPCOR Drainage Services) with 8 GB or larger non-volatile flash memory
- 12 VDC, 1A, AC/DC adapter
- External Sierra Wireless cellular modem specified by EPCOR Drainage Services
- Model CR800 or equivalent should have data logger inputs for up to three pumps and 4-20 mA inputs for wet well level and discharge flow.
- Data logger shall be programmed to obtain data on levels and flows
- Data logger programs shall be tested, reviewed and authenticated as per APEGA standards for authenticating software (See Section 2.4.1)
- Data logger 4-20 mA analog signal for monitoring wet well level and discharge flow must be wired from each transmitter through splitter (Phoenix Contact MINI MCR-SL-UI-2I-NC or equivalent latest model – consult with EPCOR Drainage Services) to both the PLC input and Data Logger input. Loss of power or communication from either the data logger or PLC shall not interrupt the signal.
- For further information on Data Loggers, contact Campbell Scientific, Edmonton.

## 2.4 SCADA System

### 2.4.1 General Requirements for PLC

Remote site PLC equipment shall communicate pumping station and other drainage facility system status, alarms and monitoring data to the SCADA host server. Where multiple remote sites have monitoring and control interlocks, control communications shall be directly (through hard wiring, radio or cellular means) between remote sites. Monitoring data and alarms shall be reported directly to the SCADA host from individual remote sites.

PLC and related control and communication equipment shall be installed within a dedicated HMI/PLC cabinet or enclosure.

PLC, SCADA and Data Acquisition Systems programs must be reviewed, tested and authenticated as per APEGA's standards. See "Guideline for Professional Responsibilities in Developing Software, V1.0, February 2016", Section 2.4.

### 2.4.2 SCADA Status and Alarms

Equipment status and alarms shall be reported from all remote drainage mechanical and monitoring facilities via the PLCs.

The requirement and priority for the status and alarm points at any given site shall be reviewed with EPCOR Drainage Services during preparation of the design. A representative sample of points for SCADA is as follows (for the complete and up to date list of alarms and statuses contact EPCOR Drainage Services):

- Pump(s) Failure for each pump (incorporate a 20 second minimum time delay prior to alarm initiation)
- Mains Power Failure (for plug-in-facilities it is indicated by a Power monitor relay de-energized, and for transfer facilities by an open contact of the transfer switch "source 1 connected and available").
- High Wet Well Level
- Dry Well Flood
- Door Entry / Door Open Status (Intrusion)
- Panel tamper / Cabinet door open status

- 
- Fire / Smoke alarm
  - Building And Dry Well Ventilator Air Flow (In Duct)
  - Pump #1 Running/Stopped
  - Pump #2 Running/Stopped
  - Pump #3 Running/Stopped
  - All Pump Hand/Off/Auto status
  - Generator Failure
  - Generator Common Trouble Including Low Battery Charge
  - Generator Running
  - Storage Facility Filling (Where storage exists)
  - Overflow to Watercourse (for sanitary and combined flows)
  - Pump Overheating for each pump (indicated by pump Mini CAS II or MAS 711 monitoring relay)
  - Liquid in Pump Motor Stator for each pump (indicated by pump Mini CAS II or MAS 711 monitoring relay)
  - Bearing Temperature for each pump (indicated by pump MAS 711 monitoring relay)
  - Automatic Valve or Gate Failure
  - Over Current for each pump motor (indicated by motor overload module or soft starter)
  - Phase Loss for each pump motor (indicated by motor overload module or soft starter)
  - Phase imbalance for each pump motor (indicated by motor overload module or soft starter)
  - Ground Fault for each pump motor (indicated by motor overload module or soft starter)
  - Jam for each pump motor (indicated by motor overload module or soft starter)
  - Stall for each pump motor (indicated by motor overload module or soft starter)
  - Loss of communications between motor overload module or soft starter and PLC for each pump motor
  - For PLC and instrument uninterruptible power supply: UPS Low Battery
  - For PLC and instrument uninterruptible power supply: UPS Failed: unable to produce alternating current
  - Carbon Monoxide and Natural gas alarm for generator room
  - H2S level HI and HIHI
  - Discharge Flow while pump is running
  - Level Sensor currently in control (when more than one level sensor are installed)
  - Sensor Signal Fail (applies to level, flow and temperature sensors)
  - Level Sensor Discrepancies (where more than one level sensor are installed)
  - Station Low Low flow alarm
  - Pump Max Runtime exceeded
  - Pump Runtime discrepancy
  - Pump vibration high (where applicable)

### 2.4.3 SCADA Analog Data

Analog data shall be reported from a remote station via the PLC. In cases where significant changes in values from an analog signal would not be reported on change of other values or statuses, report by exception control of transmission of the values shall be provided by reference to a dead band or significant values. The requirement and priority for analog data shall be reviewed with EPCOR Drainage Services during preparation of the design.

Typical points for analog data are as follows:

- Pump #1 Motor Phase B Current
  - Pump #2 Motor Phase B Current
  - Pump #3 Motor Phase B Current
  - Pump #1 Running Hours (from hardware / resettable in local HMI)
  - Pump #2 Running Hours (from hardware / resettable in local HMI)
  - Pump #3 Running Hours (from hardware / resettable in local HMI)
  - Wet Well Water Depth
  - Storage Tank Water Depth
  - Discharge Flow Rate
  - Discharge Volume per cycle
  - Discharge Volume per hour
  - Discharge Volume per day
  - Gate or Valve Position
  - Actuator torque for gate or valve actuators
  - Low Temperature alarm (depending on whether it's a building or an outdoor control panel)
  - Setpoints for Level and Flow Alarms
  - Station 12 hour discharge volume for Low Low flow warning calculations
- Pump Vibration reading where equipment supports it

### 2.4.4 SCADA Communication System

SCADA communication shall be via the EPCOR dedicated Rogers Cellular Network. Hard links for short distances, leased lines or other wireless technology with the ISM bands may be considered where cellular signal is not possible and upon approval of EPCOR Drainage Services.

Cellular Communication – Where possible, all sites shall be provided with the same model of cellular modem. The preferred cellular modem is as follows:

- Sierra Wireless AirLink RV55 (or an equivalent product in circulation upon approval of EPCOR Drainage Services)
- Class 1 Div 2 Certified
- Minimum operating environment range: –30 to 70 °C, 95 % humidity non-condensing @ 60 °C
- Mounting brackets and all hardware including antennas and surge arrest equipment where the equipment is installed outdoors
- Where insufficient Ethernet ports are encountered on the modem, provide a din rail mountable industrial 4 port switch (10/100) with an operating environmental range similar to or greater than the specifications for the modem

#### 2.4.5 Antennas

The preferred cellular antennas are as follows:

Multiband Vandal Resistant Low Profile Vertical Antenna (PCTEL MLPVMB/LTE or approved and compatible alternative available in circulation):

- LTE Band operation
- Low loss 50 Ohm coax cable, use minimal required length to minimize losses
- Provide compatible low passive intermodulation Lightning Arrestor
- UV rated plastic antenna housing for outdoor installations
- All mounting and protection hardware

Higher gain antennas shall be considered if the cellular received signal strength at the modem is -70 dBm or better. Specifications of the antenna shall be reviewed with EPCOR Drainage Services during the design phase.

Outdoor equipment enclosure sites shall be supplied with a compatible vandal resistant, low profile antenna with lightning arrest accessories. High profile vertical antenna may be used within a secured area in order to improve signal reception. The antenna shall be mounted on top of the enclosure, preferably in the center of the panel. The antenna base shall be sealed to prevent water entry into the enclosure.

For underground pumping stations, an external antenna support structure shall be provided. The antenna support structure shall be a freestanding, metal pole as close as possible to the underground facility. The pole shall be a minimum of 4.0 m in height above ground level, and sufficiently strong to resist bending, breaking or other vandalism. The pole shall be mounted on a concrete pile and grounded for lightning protection. The antenna shall be mounted on a plate attached to the top of the pole and all wires and cables shall be routed inside the antenna support pole and mounting pad to the radio/modem in the underground facility. The antenna support pole shall be visually compatible with the surrounding area (for any design adjustments contact EPCOR Drainage Services).

#### 2.4.6 SCADA Commissioning and Testing

It is a requirement of all projects to:

- Develop a list of SCADA logging and alarm points for the project with EPCOR Drainage Services
- Provide the SCADA Team 4 weeks of advanced notice to commission the station
- Develop a SCADA Tag List for the project that adheres to EPCOR Drainage Standards, and arrange for updating the SCADA databases,
- Provide the PLC code completed, tested and reviewed as per the APEGA standards for review by EPCOR Drainage Services
- Arrange for development of new or modified screens for the SCADA
- Commission and verify, in the presence of EPCOR Drainage Services staff, the proper operation of the facility, proper wiring of instrumentation, data logging and alarming of all required SCADA points, including demonstration of alarms received by SCADA server.

### 2.5 Standby Systems

2.5.1 The requirement of not needing standby power or pumping at storm pump stations shall be considered on a site by site basis. Standby power or pumping is generally not required when no significant flooding or property damage is expected to occur during a 1:100 year rainfall event as defined by the City of Edmonton Design and Construction Standards and during power failure.

2.5.2 Provision for bypass, emergency storage, standby power or standby pumping is required at all sanitary pump stations. Standby systems shall be capable of handling peak wet weather sanitary flows as determined by the City of Edmonton Design and Construction Standards.



2.5.3 Connection from at least two independent power sources such as substations is the preferred method of providing standby to pump stations. If two independent power sources are not available, a high level bypass or 4 hours of emergency storage is preferred.

2.5.4 Where connection from at least two independent power sources, high-level bypass or storage it is not feasible, natural gas or diesel fired standby power or pumping shall be provided.

2.5.5 Transfer Facility

- Automatic transfer switch rating shall match the selected utility service entrance size.
- Preferably located in a motor control center.

2.5.6 Circuit Breaker

- A circuit breaker shall be provided to isolate the standby emergency power source.
- Circuit breaker shall be rated to match the selected emergency power connection electric current capacity.

2.5.7 Emergency Power Generator

When an emergency power generator is provided, the following design concepts shall be established with EPCOR Drainage Services.

- Diesel fuel establishes independence from utility source, but requires a fuel storage tank within a heated space, a double walled fuel tank, and must be within easy reach for filling. The size of a fuel storage tank shall be a function of engine fuel consumption rate and duration of running time between fills. A fuel tank low level alarm and a fuel leak detection alarm shall be specified with the fuel tank. Black iron pipe is preferred for fuel lines. Galvanized pipe is not acceptable.
- Natural gas fuelled engines will be cleaner and not subject to a limited fuel source and preferred over diesel fuel engine, but are dependent on availability of fuel during a natural disaster event, which may disrupt the natural gas supply. Generator sets with facilities for using propane as a switchable alternative fuel supply are most preferred.
- Cummins Onan, spark-ignited types of generator sets, with natural gas main fuel supply and connection for a backup propane fuel supply mounted external to the building, are preferred.
- The size of the generator is dependent on the loading. An agreement with the EPCOR Drainage Services will be made to determine if one (1) or multiple pumps need to be connected to the generator supply.
- Generator voltage dip shall not exceed 20% during any load step.
- Generator shall be de-rated when Variable Frequency Drives without harmonic correction are used
- When a single pump is to be powered, a safety feature to disconnect any additional load such as a second pump shall be incorporated.
- Consideration shall be given to generators with electronic governors, and permanent magnet exciters.
- Generator source shall match the utility supply voltage with 347/600-Volt, 3- phase, and 4-wire as the standard source.
- Generator 'run,' trouble', 'fail' and "low battery charge" conditions shall be alarmed.
- The automatic transfer switch shall generally be located in the motor control center and shall be supplied with voltage sensor, time delays and standard safety features for phase protection, and under voltage.
- Automatic exercising control for the generator shall be included with the transfer switch.
- Digital display and analog bar graph meters shall be included with the transfer switch for adjusting transfer switch parameters and monitoring load voltages, frequency, power factor and Kilowatts.

- Provide relay output option for source 1 available, source 2 available, not in auto, and test active.
- Provide a retransfer inhibit kit with the transfer switch interlocked to pumps running status to prevent the transfer switch from retransferring to normal source until all pumps running on the generator have completed their pump down cycle and have stopped.
- Cummins OTPC Transfer switch with level 2 controls is preferred.
- Automatic battery charger, 12 Amp at 12 Volt, for the generator shall be provided with the following minimum capabilities:
  - Capable of returning a fully discharged battery to charged condition within 24 hours,
  - 4-state charging algorithm type, trickle charge, bulk charge, adsorption state and float charge,
  - Wall mounting,
  - Complete with two line LCD display of DC ammeter, voltmeter, display alarm messages, and perform programming.
  - AC input over current, over voltage and under voltage protection,
  - DC output over current protection.
  - AC input switch, LED lamps for normal charge, equalizing charge and fault condition.
  - Alarm output relay.
- Cummins Four-Stage battery charger is preferred.
- Noise reduction measures such as critical class mufflers, water-cooled engines, or acoustic blocks shall be considered.

## 2.6 Lighting

Adequate lighting shall be provided for the entire facility. The light fixtures in interior above or below-grade, clean areas shall be LED fixture Type 1. Lighting in the dry well shall be LED Type 3. Exterior light fixtures shall be LED Type 2. Lights specifications shall meet the area classification.

For separate outdoor wet wells, lighting shall be arranged to be indirect (from outside of the well) and maintainable without entering the wet well whenever feasible. Corrosive effects make installation of lights inside sanitary wet wells undesirable. Install a receptacle nearby to permit the use of a portable trouble lamp.

For wet wells forming part of the lift station building with an upper equipment room and lower level wet well the upper equipment room lighting shall be Type 4 and the lower level wet well lighting shall be Type 5. All fixtures shall be located and installed to allow easy access for maintenance.

Unit Equipment emergency lighting units Type 6, shall be provided for plug-in facilities. Remote lamp heads to be provided at the lowest dry well levels as practical. Emergency lighting units shall be on same circuit as room lights, as required by C.E.C. 46-304(4)

Exterior lights shall be provided to illuminate all building entrance areas and outside equipment access locations.

Supply and install the following type of fixtures:

- Type 1: Surface ceiling-mount LED light fixture, which is equivalent to 1200 mm long, fluorescent light fixture, 2-34 watt, cool white T-8.
- Type 2: Exterior wall mount LED light which is equivalent to high-pressure sodium light fixture 35 Watt, 120VAC, vandal-resistant, polycarbonate lens, bronze housing, with photocell control.
- Type 3: Dry well LED lighting, vapour tight, equivalent to 32-watt compact fluorescent, 120-volt, wall or ceiling mounting, polycarbonate clear globe.
- Type 4: Wet well equipment room LED lighting, 600 mm long, Class I, Zone 2, Hazardous area, equivalent to 39-watt compact fluorescent, non-metallic FRP housing, clear acrylic lens, 120-volt.

- Type 5: Wet well lower level LED lighting, Class 1, Zone 2, Hazardous and Category 2 area, equivalent to 32-watt compact fluorescent, non-metallic, 120-volt, wall or ceiling mounting, polycarbonate clear globe.
- Type 6: Emergency Light, self-contained, Type 4X enclosure, sealed lead maintenance free battery, 6 Volt, 2 @ 8 Watt integral Halogen sealed beam heads, push to test switch, low battery disconnect, and provision for remote heads. Battery sized for a minimum time period of not less than 30 min.

## 2.7 General Construction and Wiring

### 2.7.1 Labelling

All electrical equipment, junction boxes, control panels, instruments and power equipment shall be clearly labelled with Equipment Tag number, Equipment name or function and power source and Breaker number by means of 2-layer, 2.5 mm thick, matte finish, lamicoid nameplates with black letters on a white background. Labels shall state the full name of the equipment. Use of abbreviations or references from the construction specifications and drawings alone is undesirable.

All breakers in MCCs or power distribution centers and low voltage distribution panels shall be labelled with a number and the equipment it supplies.

All motor starters in MCCs or individually mounted shall be labelled with a tag number and the equipment it supplies.

Each instrument and control device shall be labelled with a stamped or engraved tag number. Stamped tags shall be stainless steel. Tags to be affixed to instruments and control device with nylon tie wraps or adhesive. Do not use adhesive on curved surfaces.

- Provide signage for operational instructions, overflow or flood levels, and pump start/stop set points.
- Label all power, control, instrumentation and data cable/conduit with a unique tag number. Label where cable/conduit enters a device, panel or electrical equipment. Tag number is to identify where the opposite end of the cable/conduit terminates.
- All conductors shall be identified and numbered in accordance with the control schematic. Labels shall be of the heat shrink type, appropriately sized for the size of wire. Adhesive tape style labels are not acceptable.

### 2.7.2 Wiring

- All pump power cables in dry wells shall be continuous without splice or junction between the motor and the starters where possible.
- All pump power cables in wet wells shall be wired to terminals in junction boxes installed outside of wet wells, and above any flood levels. Cables in the wet well shall be supported with stainless steel Kellom cable grips. Provide a reasonable amount of spare pump cable between Kellom support and junction box to facilitate pump removal and reinstallation. Power wiring from junction box to motor controller to be sealed as required by the CEC. Wet well is rated Class 1, Zone 2, and Category 2 corrosive.
- All VFD motor feeders shall be shielded type, with flexible armour and PVC outer jacket where installed on cable tray or run in RGS conduit.
- Ultrasonic level sensor cables shall be shielded, run in RGS conduit and spaced 300 mm from any 600 volt motor feeders. (Note: VFD motor feeders have caused interference with ultrasonic level sensor signals.)
- To alleviate corrosion in the wet well areas all wiring power, control or instrumentation to be tinned or coated with Penetrox A-13 prior to termination.
- There shall be no disconnecting switch or junction box in a cable below ground level.
- All cables for level sensor transducers and float switches in the dry wells shall be continuous

without splice or junction between the device and control panel where possible and shall be supported from cable grips.

- All cables for level sensor transducers and float switches in wet wells shall be continuous without splice, and wired to terminals in junction boxes, which are installed outside of wet wells, and above any flood levels. Cables in the wet well shall be supported with stainless steel Kellem cable grips. Wet well is rated Class 1, Zone 2 and Category 2 corrosive.
- Equipment suitable for non-hazardous locations may be used in Class 1, Zone 2 hazardous locations under the following conditions:
  1. The equipment can be switched off at any time, without warning, without causing any hazards;
  2. An audible and visual alarm is actuated when the combustible gas concentration reaches 20% of the LEL; and
  3. The equipment is automatically disconnected from the electrical supply when the combustible gas concentration reaches 40% of LEL.
- Verify that the cables supplied with motors are long enough for requirements. Excessive lengths of cable shall not be left in wet wells.
- Verify that the pump motor amperage and leakage protection wiring is provided in the pump power feeder composite cable.
- Level switches and other sensing devices, not rated for a Class 1, Zone 2 area will require an intrinsically safe barrier at the control panel.

### 2.7.3 Electrical Cables, Conduits and Pull Boxes

- Use rigid PVC conduit and fittings for all work in the dry well.
- Use only Teck cable with putty type sealing connectors approved for Class 1, Zone 2 and Category 2 for all work in the wet well. If Teck cable length is 10 m or longer no seals are required.
- Install all pull boxes in the dry well above ground level.
- Install all pull boxes for the wet well outside the well area, where possible.
- Where electrical metal tube (EMT) is used in areas other than wet or dry wells, only water tight connections will be used. No set screw connectors shall be used.
- EMT and rigid conduit system will use FS (standard) or FD (deep) cast aluminium boxes with matching cover for surface mounted outlets.
- Conduits will be cast aluminium with threaded hubs solid gaskets and cast covers.

### 2.7.4 Location of Electrical Equipment

- All electrical and control equipment shall be located such that it cannot be flooded under any foreseeable circumstances.
- Local safety disconnect switches shall be located above potential flood level.
- Any disconnect switches located away from the pump locations shall be lockable.
- Switchgear and combination magnetic motor starters shall be lockable and located adjacent to the control panel.
- Portable Start/Stop Station for Pumps: In a deep dry well pump application, provide a submersible push-button control receptacle mounted 1200 mm above the dry well floor, which shall be wired to MCC and shall allow remote control of pumps using a portable start/stop station in the dry well. The MCC shall be equipped with a four-position selection switch (Hand/Off/Remote/Auto) to allow the required remote operational function. The intent is to allow operators to carry a portable start/stop station and remotely control pumps (start/stop) at the dry well floor level for the pump service/maintenance purposes. Refer to Drawing 03-E24 for details of the remote control

receptacle and portable start/stop station for pumps.

#### 2.7.5 Pump Station Electrical Protection Requirements

- Facilities with an automatic transfer switch shall have the following Electrical protection features provided by the transfer switch: phase imbalance, phase loss, phase reversal and low voltage.
- Surge Protection shall be provided for all facilities. Cutler-Hammer, Supervisor Series is the preferred product providing:
  - 160 kA/phase surge rating,
  - 3 phase wye connections,
  - fault indicator lights/phase,
  - form C alarm contact,
  - audible alarm,
  - transient counter,
  - push to test,
  - power quality meter, and
  - A-B MCC mounting.

#### 2.7.6 Receptacle Requirements

- 120-volt ground-fault-protected receptacles shall be provided, as necessary, for convenient power supplies throughout the facility (except the wet well).
- Minimum receptacle requirements are as follows, on at least two separate circuits, each on their own circuits:
  - One at the control panel.
  - One within the dry well (where applicable).
  - At least one outside of the building. External receptacles shall be under lockable weatherproof covers.
  - An additional 120 volt circuit shall be provided solely for the dry well sump pump.

### 2.8 Pump Station Control

#### 2.8.1 Control/SCADA Panel – General Requirement

- A control/SCADA panel shall be provided for control and monitoring of pumps, gates, valves and other station equipment operation.
- The panel must be located so that it cannot be flooded under any foreseeable circumstance.
- Care must be taken when transmitting analog signal level changes over SCADA to limit the number of transmissions to a reasonable number to prevent communication system overload and excessive communication charges.

#### 2.8.2 Pump Control Requirements

- Provision shall be made to automatically alternate between at least two pumps in normal service. Controls shall also be provided such that if, with one pump operating, the sewage level in the wet well continues to rise, then the additional pump or pumps shall automatically start once the sewage level reaches a higher set point or points.
- If in a two-pump station, one pump should fail to start for whatever reason or if the Hand-Off-Auto switch is in Off, the PLC logic shall generate only a single pump failed to start alarm and transfer all control to the remaining working pump.
- This pump control shall not apply if the design philosophy specifically states that only one (1) pump

shall be used, as in the case where downstream capacity is not available and/or storage is utilized for inflow rates in excess of pump capacity.

- If an active pump fails in a station with a standby pump, the standby pump shall assume the failed pump operation. This pump sequencing shall remain constant until the fault has been rectified.
- Tripping the high level float switch shall also start one or more designated pump(s) through PLC control, if no pump was running.
- Where the electrical power service or standby power is not capable of supplying all pumps simultaneously, full operation shall be prevented by the use of electrical interlocks.

### 2.8.3 Gate and Valve Control

To avoid a high rate of wear, control delays or stepped motion increments shall be utilized to minimize gate or valve response frequency resulting from rapid and slight changes in monitoring levels.

### 2.8.4 Station Control/SCADA Enclosure

- For new installations, all control and SCADA equipment shall be located in one panel.
- Indoor enclosures shall be CSA Type 12, casketed. Indoor enclosures shall be wall mounted using available space in the site equipment room. Indoor enclosures shall be un-insulated and ventilated.
- All outdoor enclosures shall be CSA Type 4X stainless steel supplied with a hinged, pad-lockable door. Outdoor enclosures shall be heated and shall be supplied with air vents to prevent extreme heat. Enclosures for outdoor sites shall be frame-mounted. Frames shall be anchored to two concrete piles. Wherever possible, one frame size shall be used for all enclosure sizes to standardize on installation and mounting details.
- To provide trouble free operation during extreme hot and cold temperatures, outdoor enclosures shall be insulated with 25 mm fire resistant, high R-value, foam insulation on all the inside surfaces of enclosure walls, floors, ceilings and doors. Insulation shall be specified for exposure to high temperatures that may be experienced during hot summer days. Equipment panels shall be mounted on studs to clear the insulation without compression.
- The SCADA enclosure shall contain, but not be limited to, the following:
  - Cellular radio modem (Section **2.4.4**)
  - Cellular antenna (Section **2.4.5**)
  - Allen Bradley PLC (Section **2.8.5**)
  - UPS (Section **2.8.6**)
  - 120 VAC to 24 VDC power supply (Section **2.8.7**)
  - 400 watt blower/heater with integral thermostat, quantity as required to suit size of enclosure (outdoor enclosures only). Hoffman D-AH electric heaters are preferred.
  - Smoke detector (outdoor enclosures only)
  - Terminal strips as required
  - Door switch (outdoor enclosures only)
  - Temperature transducer with minimum range -40°C to 100°C (outdoor enclosures only)
  - Air vent
- Control wiring shall be #16 AWG, TEW wire, with appropriate fuse protection. Auxiliary control relays, if required, shall be Omron, Potter-Brumfield, or Allen-Bradley of the octal-base type, 8-pin, general-purpose relay, with a minimum contact rating of 10 amps. Time delay relays, if required, shall be Omron Type H3BA, or Allen Bradley, or an approved equivalent industrial grade. Indicating lights, pushbuttons, and selector switches, where required, shall be 800T style, 30.5 mm, Allen-Bradley.

- Both indoor and outdoor assemblies shall be located as close to existing equipment as possible, to minimize lengthy cabling between enclosures. Coordinate exact location with EPCOR Drainage Services. All interconnecting wiring shall be run in conduit. Conduit between outdoor enclosures shall be trenched in as required.
- For new installations the SCADA shall be integrated into the station control system PLC.

#### 2.8.5 Programmable Logic Controller (PLC)

- Primary process communications between the PLC and soft starters, or VFDs, shall be via Ethernet/IP; and shall be Ethernet/IP, or Modbus, between the PLC and other control equipment. Analog and discrete communications shall be provided as backup.
- Automatic pump control for typical lead and lag, and duty and standby types of operation shall be by means of the ultrasonic level controller c/w relays and analog output. Analog output shall be connected directly to the station PLC for Control of the pumps. Relays of the level controller are hard wired in pump motor starters for backup control in the event of PLC failure. Pump control must be independent of operation of local indication or annunciation equipment. In the eventuality of a level controller failure the pump control shall be provided through the PLC by using the high and low level alarm level switches.
- For control of large and medium size pump stations and gate stations with large I/O counts, smart motor controllers and Real-Time control masters, supply and install an Allen Bradley CompactLogix PLC.
  - 1769-L33ER CompactLogix Processor (or approved alternate, contact EPCOR Drainage Services) (Quantity 1)
  - 1769-PA4 120 VAC power supply (Quantity 1)
  - 1769-IA16 PT. 120 VAC input module (Quantity as required by individual site requirements)
  - 1769-OW8I 8PT. Isolated relay output module (Quantity as required by individual site requirements)
  - 1769-IF4 4 channel analog input module (Quantity as required by individual site requirements)
  - 1769-OF4 4 channel analog output module (Quantity as required by individual site requirements)
  - 1769-ECL Left end cap
  - 1769-ECR Right end cap
  - Other modules as required to support facility equipment
- For control of small pump stations, gate stations, level monitoring stations and other small sites, supply and install an Allen-Bradley MicroLogix 1400 Processor
  - 1766-L32AWA MicroLogix 1400 processor with two RS-232 ports and one EtherNet port, 20 digital 120VAC inputs, 12 relay outputs
  - 1766-MM1 Memory Module for MicroLogix 1400
  - 1762 MicroLogix Expansion I/O modules as required to support facility equipment
  - All required cables
- For major pump stations and complex gate control stations, using A-B CompactLogix, provide Allen Bradley Panelview Plus 10" touch screen operator interface with multiple screens for:
  - Overall system layout, showing remote sites
  - Level /flow real-time monitoring and trends
  - Pump status
  - Gate status

- 
- Local control of pumps
  - Local control of gates
  - Set points
  - Alarms
  - For smaller sites provide Allen Bradley Panelview Plus 10" touch screen operator interface as required by EPCOR Drainage Services.
- 2.8.6 Uninterruptible Power Supply (UPS)
- Eaton Powerware 9SX1000, 1000 VA with extended battery module or approved alternate UPS shall be provided to power control/SCADA equipment and shall have the following features:
- 120 VAC, 1000 VA Uninterruptible Power Supply
  - 50/60 Hz auto sensing
  - Operating Temperature: 0 - 40°C (32 - 104°F)
  - LCD display of UPS meters and settings
  - Battery type to be maintenance-free
  - UPS battery adequate for minimum 1 hour back-up
  - Extended battery module for 1 hour back-up time
- 2.8.7 24 VDC POWER SUPPLY FOR SCADA PANELS
- 24 VDC switched mode power supply shall meet the minimum requirements as follow:
- Input range 85 – 132 VAC
  - Minimum 100 Watt
  - Efficiency >90%
  - Ripple/Noise <100 mVPP
  - Minimum operating Temperature Range - 25°C to +70°C
  - Certification UL1950, CSA
- 2.8.8 Pump Motor Starters and Overload Protection
- i. Electrical protection for individual pumps regardless of type of motor starter or variable frequency drive shall have protection for phase imbalance, phase loss, phase reversal, and low voltage in the form of a multifunction monitoring relay located in pump motor starter or drive. Provide a Carlo Gavazzi, true RMS 600 VAC, 3-phase DPC voltage monitor relay, or approved equivalent replay, with its own fuses rated 3 amp. The Carlo Gavazzi relay is to operate to shutdown a pump or prevent a pump from starting before the pump overload or drive protective functions trip to lockout the pump. A single relay for all pumps in a station is not acceptable.
  - ii. Where the Engineer determines, through hydraulic transient analysis, that maximum pressures are within the capacity of the pipe system but repeated hydraulic surge effects or excessive slamming of check valves may cause damage or a significant reduction in the useful life of the pipe system, or excessive noise; then the preferred method of eliminating such effects is with soft start/stop motor controllers such as SMC with Pump Control Option designed specifically for control of pump motors.
  - iii. Full-voltage, electric motor starters shall be Allen-Bradley combination circuit breaker and magnetic type starters, rated for the line voltage specified. Combination starters shall include a control transformer with primary and secondary fusing. Contactors for motor starters shall be selected in accordance with NEMA standard ICS2-321 for jogging and plugging duty and shall have replaceable contacts and coils. Short circuit protection devices shall be provided in



accordance with the Canadian Electrical Code such that the contactor or starter shall cause no damage to persons or the installation, and shall be suitable for further use after reconditioning if necessary. Contactors rated in accordance with both NEMA and IEC standards shall be marked with the NEMA rating only. MCCs and combination motor starters manufactured by Allen-Bradley are preferred. The designer shall be required to provide justification for the selection of alternative equipment, and this selection shall be subject to the approval of EPCOR Drainage Services.

- iv. Where soft start/stop type of motor starters are required, they shall be Allen-Bradley Smart Motor Controller SMC-50, or SMC Flex with pump control option, and appropriately sized for specified motor loads. Where a bypass contactor is provided once pump reaches full speed, each SMC-50 motor controller shall be fitted with an Allen-Bradley 150-SM2 current transformer expansion module, and an 825-MCM converter module to ensure current metering/protection is not lost. For SMC Flex motor controller, a separate overload must be provided when a bypass contactor is implemented. SMC motor starter configuration shall be specified by the Engineer in consultation with EPCOR Drainage Services. SMC motor starters shall be programmed by the Contractor with assistance from manufacturer's service representative as required.
- v. All pump motor starters, full voltage and SMC types, shall be complete with Allen Bradley Bulletin 800T, 30.5 mm Hand/Off/Auto selector switch, red "run" pilot light and "Mushroom" type emergency stop push button and Hobbs elapsed time meter (available at Gregg Distributors, Edmonton). Emergency stop buttons shall override the stop option of Smart Motor Controllers.
- vi. Adjustment of trip settings of all overloads and circuit breakers shall be done to correctly coordinate tripping order. Overloads shall be adjusted to suit the full-load current without nuisance tripping. HMCP (motor circuit protectors) breakers shall have the magnetic trip settings adjusted to the appropriate setting.
- vii. If full-voltage pump motor starters are used, they shall each include an Allen-Bradley, Bulletin 193/592, E300 overload relay for protection against overload, phase loss, phase imbalance, ground fault, jamming and stalling. The E300 shall be connected to the programmable logic controller by means of the relay outputs and the standard Ethernet/IP communications system, to convey the following information:
  - Average electric current in the motor
  - Percentage of thermal capacity utilized
  - Full-load current settings
  - Manual Reset after trip
  - Trip cause and warning indications:
    - Overload
    - Phase loss
    - Current imbalance (warning only)
    - Ground fault (warning only)
    - Jam
    - Stall
    - Loss of communication with programmable logic controller (warning only)
- viii. If Allen-Bradley Smart Motor Controllers (SMC) are used, they must each be connected to the programmable logic controller by means of output replays and Ethernet/IP communication to convey the following information:
  - Pump running status
  - Average electric current in the motor
  - Percentage of thermal capacity utilized

- 
- Full-load current settings
  - Manual Reset after trip
  - Trip cause and warning indications:
    - Overload
    - Phase loss
    - Current imbalance (warning only)
    - Ground fault (warning only)
    - Jam
    - Stall
    - Loss of communication with programmable logic controller (warning only)
- ix. Where the engineer determines that variable speed pumps shall be used, the preferred VFD shall be from the Allen-Bradley PowerFlex ranges, appropriately sized for specified motor loads, with integrated silicon control rectifier fusing. VFD configuration shall be specified by the Engineer in consultation with EPCOR Drainage Services. VFDs shall be programmed by the Contractor with assistance from manufacturer's service representative as required. If a PLC is used for station control the variable frequency drive shall be connected to the PLC by means of a standard EtherNet/IP communication system, to convey the following information:
- Average electric current in the motor
  - Percentage of thermal capacity utilized
  - Full-load current settings
  - Manual Reset after trip
  - Trip cause and warning indications:
    - Over current
    - Phase loss
    - Phase imbalance (warning only)
    - Ground fault (warning only)
    - Jam
    - Stall
    - Loss of communication with programmable logic controller (warning only)
- x. Starters and VFDs shall be preferably mounted in a Motor Control Center or alternately if approved by EPCOR Drainage Services CSA type 1, general- purpose enclosure with a disconnect device operating mechanism, interlocked with the enclosure door to prevent opening of the door with the device in the "ON" position. The operating handle shall be lockable in the "OFF" position with up to three padlocks. If VFDs are located in control panels, the control panel voltage shall be limited to 250 V maximum.
- xi. Where Smart Motor Controllers and VFDs are mounted in motor control centers, install remote mount operator interface modules on the MCC doors. If remote mount operator interface modules are not available, provide windows in the MCC doors to allow viewing the liquid crystal displays on the drives without opening the doors.

### 2.8.9 Non-pump Motor Starters and Overload Protection

Full-voltage starters shall comply with Section **2.8.8 ii** and have the following features.

- Hand/off/auto selection
- Red, run pilot light
- Allen Bradley Type E2 overload relay, or approved alternate.

## 2.9 Level Controllers/Float Switches

### 2.9.1 Primary Level Controller

i. Ultrasonic level sensor from Siemens (Milltronics) range of ultrasonic level sensing and control devices shall be the primary level sensing device, where applicable. Acceptable models include:

- MultiRanger 200
- SITRANS LUT400
- HydroRanger 200

Or a Drainage engineer approved equal. The proposed device should be vetted with EPCOR Drainage Services early in the design process.

The models with Ethernet/IP or Modbus communications interface to PLC are preferred for typical wastewater applications, unless other features are required.

The level controller shall be mounted in the control/SCADA panel or on a wall near the control panel at an easily viewable and accessible location. Configure the level controller with automatic control functions indicating pump cycle alternation and fail-safe mode appropriate to the design requirements of the station.

ii. Transducer Type

Siemens (Milltronics) XPS-15 ultrasonic transducer is preferred where feasible (0.3 to 15 m depth) and is compatible with all approved Siemens level controllers. Where deeper applications (0.6 to 30 m depth) are required the XPS 30 ultrasonic transducer is preferred. The XPS 30 is compatible with the LUT series controllers only. Other transducers may be considered where warranted and approved by EPCOR Drainage Services. Level controllers shall be installed in accordance with Standard Drawing E4.

iii. Transducer Installation - Wet Well, Tanks and Manholes

The ultrasonic level transducer shall be installed in accordance with the specifications in the ultrasonic manufactures manual, in a PVC rigid guide pipe extending to an elevation above potential flood level in the wet well. The transducer shall be fitted with a custom made plastic collar to insure that transducer remains central. The transducer face shall be flush with the bottom of the guide pipe. There shall be an unobstructed path for the cone shaped sound wave transmission from the transducer to the water surface and back.

The installation of the transducer and the range and span settings shall cover the full range of variation of the liquid level from the bottom of the well, tank or manhole as datum to the highest level of concern, such as overflow or flood level.

Prior to commissioning, the transducer installation shall be checked and adjusted as necessary to insure a stable, satisfactory signal confidence reading at the ultrasonic controller

### 2.9.2 Alternative Primary Level Transmitters

At locations where it is not feasible to measure accurately or reliably liquid level over the full range of level variation with an ultrasonic level sensor, a hydrostatic level sensor or radar level sensor, with 4-20mA output, may be used on approval of EPCOR Drainage Services instead of or in conjunction with an ultrasonic type level sensor.

Preferred types of hydrostatic level sensor include: Model 311-M351 as manufactured by GP50 with

a Tefzel cable for chemical resistance is EPCOR Drainage Services' preferred pressure transducer.

The preferred radar level sensors are VEGAPULS and Siemens SITRANS LR series.

Where multiple level sensors of different types are used, and normal operation may render a level sensor inoperative, such as exceeding the span of an ultrasonic transducer, transmission of a fault alarm should be inhibited while the liquid level exceeds the span.

### 2.9.3 Multiple Primary Level Controllers

At locations where the depth, operating conditions, or layout of the wet well make the reliability of a single type of level sensor questionable, three or more sensors of at least two different types shall be provided. The station programmable controller shall compare the readings from the different sensors to identify any sensor signal that may be erroneous but an acceptable amount of sensor drift shall be programmed into the controller. A reading found to be in error shall be rejected for control and identified in the SCADA system with an alarm. Consideration shall be given to the potential causes and consequences of level sensor failure when choosing the level sensing system.

### 2.9.4 Level Switch Installation for Wet Well and Dry Well

Float switches to be Flygt ENM-10, micro-switch design. Mercury type, float switches are not acceptable.

A float switch shall be provided in the dry well for a flooding alarm, set at an appropriate elevation near the bottom of the well. Where a sump pit is incorporated, a float switch shall be installed within the sump pit.

A float switch is to be provided in the wet well to serve as a backup to the ultrasonic.

High Water Level sensor in the event of a failure. The high level switch alarm shall be programmed in the PLC to energize one designated pump, if no pump was running.

A float switch is to be provided in the wet well to serve as a backup to the ultrasonic Low Water Level sensor in the event of a failure.

Where applicable a separate float switch shall be provided in the wet well suspended at an appropriate elevation to detect an overflow condition, and activate an alarm.

Dry well float switches are to be directly connected to the PLC.

Wet well float switches shall be installed in accordance with Standard Drawing E4 and Section **2.7.2** Wiring.

### 2.9.5 All level sensor transducers and float switches shall be mounted so that they are easily removable and serviceable without entry into the wet well.

All cables for the devices shall be factory sealed and shall be of sufficient length to reach the control panel or above grade junction box and PLC without any intermediate splices. Junction boxes must be installed outside wet wells and above any flood level.

### 2.9.6 Wet wells and other chambers with flowing wastewater are rated as a Class 1 Zone 2 hazardous area and the Flygt level switches shall require an intrinsically safe relay in the control panel and field wiring isolated from all other panel wiring.

## 2.10 Flow Meter

### 2.10.1 Forcemain flow meters are required in all pump stations unless otherwise approved by EPCOR Drainage Services. The flow meter shall be a magnetic flow meter with a remote secondary flow transmitter mounted in the control panel or on a wall near the control panel at an easily viewable and accessible location. Other types of flow meters may be considered if approved by EPCOR Drainage Services.

### 2.10.2 Primary Flow Element and Flow Transmitter

Endress + Hauser Promag W400 or approved alternate, including:

- Hard rubber or neoprene liner, or Teflon liner where chemicals deleterious to rubber such as ferric chloride, are present in the wastewater.
- Electrodes: 316 SST flush type.
- Supply 316 SST ground rings or magmeter integral ground electrode when
- Installed in lined pipes.
- Minimum 5 pipe diameters upstream and 3 pipe diameters downstream straight pipe run or manufacturers recommendation if less. Magmeters are available with very short upstream/downstream pipe runs if necessary.
- Installed ahead of control valves.
- Installed in piping which shall maintain a full pipe at all times.
- Ground with minimum #8 AWG copper to main station ground grid.
- Installed in vertical pipes, where possible, to even out wear on the liner.
- Install cables/conduits to provide watertight seal to guard against accidental submergence.
- Wall or cabinet mount transmitter
- Dual LCD readouts for instantaneous and total flow
- The flow transmitter shall communicate with the PLC via Ethernet/IP

## 2.11 Heating and Ventilation

- 2.11.1 Specify power connections to all mechanical heating and ventilation equipment. Specify disconnect switches where required and where not provided with the equipment. Verify all equipment sizes and power requirements with the mechanical designer.
- 2.11.2 Specify conduit for all low-voltage control wiring. Co-ordinate exact locations and routing with the mechanical designer.
- 2.11.3 Ensure that air supply fan is permanently energized to maintain continuous airflow in the dry well.
- 2.11.4 Specify a paddle type flow switch in the dry well air duct, Johnson Control Type F62AA, and connect to the PLC system. Mechanical designer shall select a location in duct that is free of air turbulence.
- 2.11.5 Provide interlock control circuitry between air exhaust fan and make-up-air unit where applicable.
- 2.11.6 Where electric heaters are required, units shall be sized to required BTU output and specified with internal thermostatic control, connected to the main power supply. Unit rating shall be adjusted to permit 'off-the-shelf' purchase.
- 2.11.7 For pump stations requiring wet well ventilation, there shall be an interlock between fans and motorized dampers to prevent the escape of odours when the fan is not running.
- 2.11.8 Ventilation and damper controls for generators and the building shall operate from a common, compatible voltage and signal.
- 2.11.9 The design of wet well ventilation systems shall be such that the fan motor and electrical wiring shall be external to the ventilation conduit/duct.
- 2.11.10 In accordance with Alberta Environment Standards and Guidelines for Municipal Waterworks, Wastewater and Storm Drainage Systems, wet well ventilation shall be designed to provide continuous 6 air changes an hour or 30 air changes an hour during occupation. Provisions for portable ventilators in lieu of permanent ventilation may only be considered on approval from EPCOR Drainage Services. Intermittent ventilation of 30 air changes an hour is a generally preferred operating mode depending upon the size and type of the pump station. Coordinate with EPCOR Drainage Services for the preferred/required ventilation mode on each project.

## 2.12 Renovation of Existing Facilities

- Where appropriate, include in the contract price, the removal of electrical equipment and conduit and wiring from the existing lift station subject to modification or upgrading.
- Prior to disposal of equipment, invite EPCOR Drainage Services staff to salvage any items that may be of use at other locations.
- Prior to construction of new work, arrange for temporary power connection to pumping facilities and as described in the general contract documents.

## 2.13 Miscellaneous Systems

### 2.13.1 Building Temperature

Specify a temperature transmitter with 4-20mA output, -40 to 100°C range, mounted on a wall in the pump house and connect to the PLC.

### 2.13.2 Intrusion Alarm

Specify heavy-duty lever-operated switches (Allen-Bradley 802 T-D or equal) on exterior access hatches or exterior doors, connected to the alarm system and operated at 120 VAC, from the PLC.

### 2.13.3 Fire Alarm

Specify an American Sensors model ESA5011 ULC certified smoke detection device, operated at 120 V AC, from the UPS.

Auxiliary relay output contact, connected to the PLC.

Smoke detection devices are required inside outdoor-mounted enclosures. Smoke detection device(s) are required in main equipment and generator set rooms of pump houses.

### 2.13.4 Electric Hoist

When required show power to the hoist drive, complete with a disconnect switch. Verify the exact location and load requirement with the process engineer.

For hoists of 1 tonne or less, portable hoists shall be provided with Class 1, Zone 1 rated plugs and receptacles.

### 2.13.5 Storage Pond Gate Control and Level Monitoring Sites

The standard PLC preferred by EPCOR Drainage Services is the A-B CompactLogix. However for gate control and level monitoring sites which require very few I/O the A-B PLC may be a MicroLogix. See Section **2.8.5** for details.

Level monitoring shall utilize a Siemens (Milltronics) MultiRanger 200. Refer to Section **2.9.1** for additional details.

### 2.13.6 Storage Tank Facilities Level Monitoring

Level monitoring shall utilize an approved listed ultrasonic device

### 2.13.7 Portable Start/Stop Station for Pumps

For stations with deep dry well pump installation, provide a submersible remote control receptacle 1200 mm above the dry well floor complete with a portable start/stop station. Refer to Section **2.7.4**, and Standard Drawing E24 for further details.



---

### LIST OF STANDARD ELECTRICAL DRAWINGS

03-E1	Electrical Symbol Legend
03-E2	Typical Electrical Building Plan
03-E3	Typical Dry Well - Section
03-E4	Typical Wet Well - Section
03-E5	Typical Wet Well - Plan View
03-E6	Wet Well with Interior Electrical Boxes – Section
03-E7	Wet Well with Interior Electrical Boxes - Plan View
03-E8	Typical Level Transducer Leads Mounting Detail
03-E9A	Typical Single Line Power Diagram
03-E9B	Typical Single Line Power Diagram with Generator Set and MCC
03-E10	Typical Main Panel Assembly and Panel System Capacities Schedule
03-E11	Outdoor Enclosure Assembly
03-E12	Exterior Panel Enclosure
03-E13	Typical Panel Schedules
03-E14	Control Panel Detail with PLC
03-E15	Typical PLC Layouts
03-E16	Typical FVNR Pump Motor Control
03-E17	Pump Motor Control Schematic (with Soft Starter)
03-E18	Typical AC Power Distribution
03-E19	Typical Pump Protection Relays Control Schematic
03-E20	Typical PLC Inputs Slot 1
03-E21	Typical PLC Inputs Slot 2
03-E22	Typical PLC Outputs Slot 3
03-E23	Typical Analog Inputs
03-E24	Portable Start/Stop Station for Pumps

Note: Standard Electrical Drawings will be provided on request.

### USER-FRIENDLY DRAWING

188 North Edmonton Sanitary Trunk Stage NC1

# North Edmonton Sanitary Trunk Stage NC1

11410 153 AVENUE

SANITARY LIFT STATION

SEPTEMBER 2019  
Page 1

BY-PASS	BY-PASS MANHOLE	EMERGENCY BYPASS PUMP CONNECTION	PUMPING HEADS WET WELL TO SURFACE	PUMPING HEADS WET WELL TO FORCEMAIN OUTLET
	288984	NONE	18.21m	14.23m

## Emergency Notes

- Nearest manhole not draining to the same pump station: Castledowns Road and south of 153 Avenue (manhole #288984)
- Emergency bypass pumping connection does not exist.
- Pumping heads: Wet well to surface: 18.21m (at pump station)  
Wet well to forcemain outlet: 14.23m

## Definition

- It is a 2.92 meters storage tunnel extended from 127 Street to Castledowns Road on 153 Avenue.
- The pump station is connected to the storage tunnel at Castledowns Road north of 153 Avenue.

## Purpose

- The storage tunnel is here to store any excessive sewage entering the city's drainage system during rainstorms period, and collect sewage from the newly built residential areas.
- The pump station is here to drain the storage tunnel.

## Function

- The sewer trunk currently carries inflows from Oxford and the Palisades Neighborhood.
- The tunnel is also designed to collect inflow from Dunluce Neighborhood in the future.
- In a dry day, the pump will start pumping when the wet well level reaches elevation 662.50m.
- During extreme rainstorms, the tunnel can be surcharged to the overflowing elevation at 674.305m.

## Check & Maintain

- Slide gates
- Debris and solid settlements



# North Edmonton Sanitary Trunk Stage NCI

11410 153 AVENUE  
SANITARY PUMP STATION

SEPTEMBER 2019  
Page 2

391633  
PUMP WELL  
**188**

## North Edmonton Sanitary Trunk Overall Site Plans

PLAN VIEW

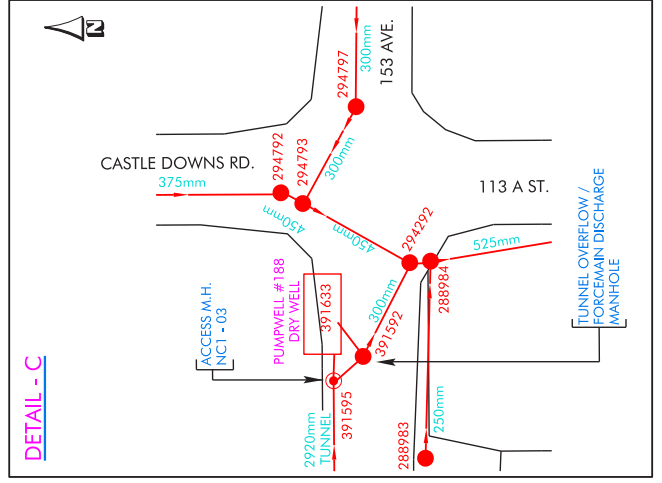
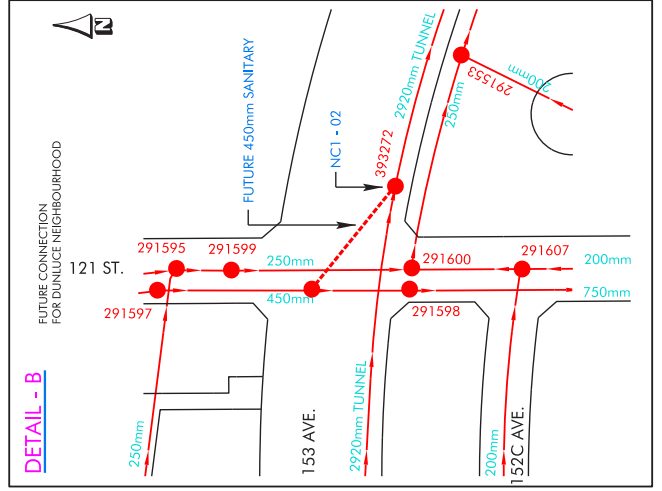
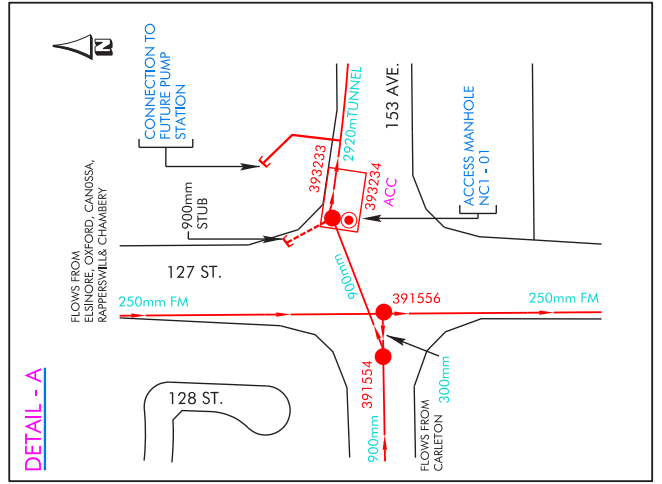
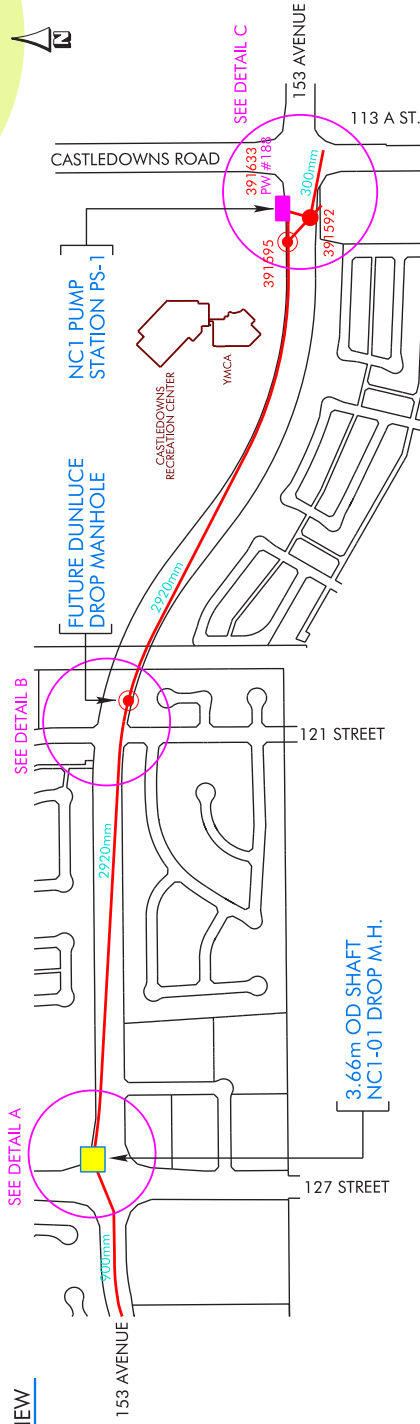

**North Edmonton Sanitary Trunk  
Overall Site Plans**

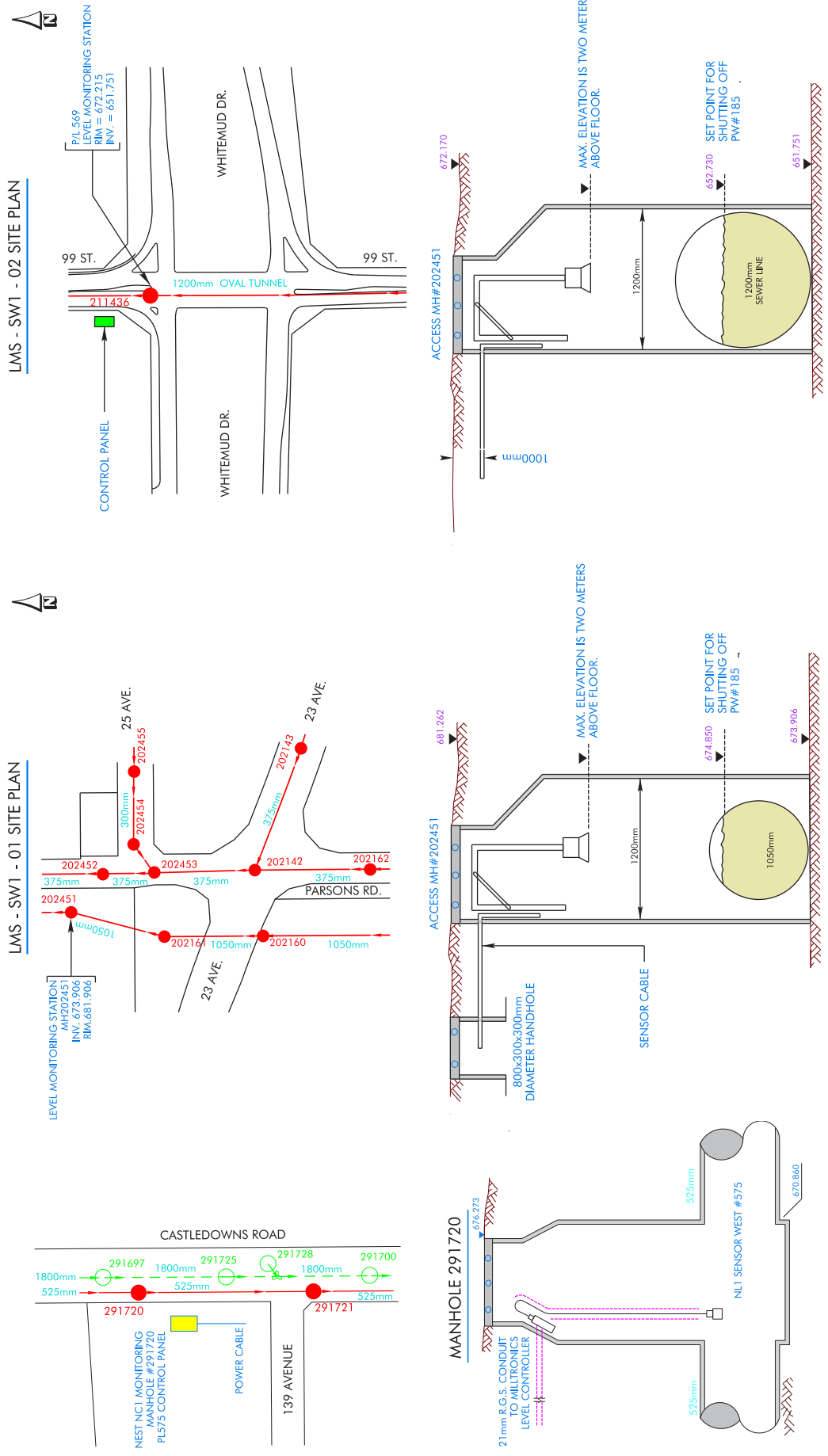

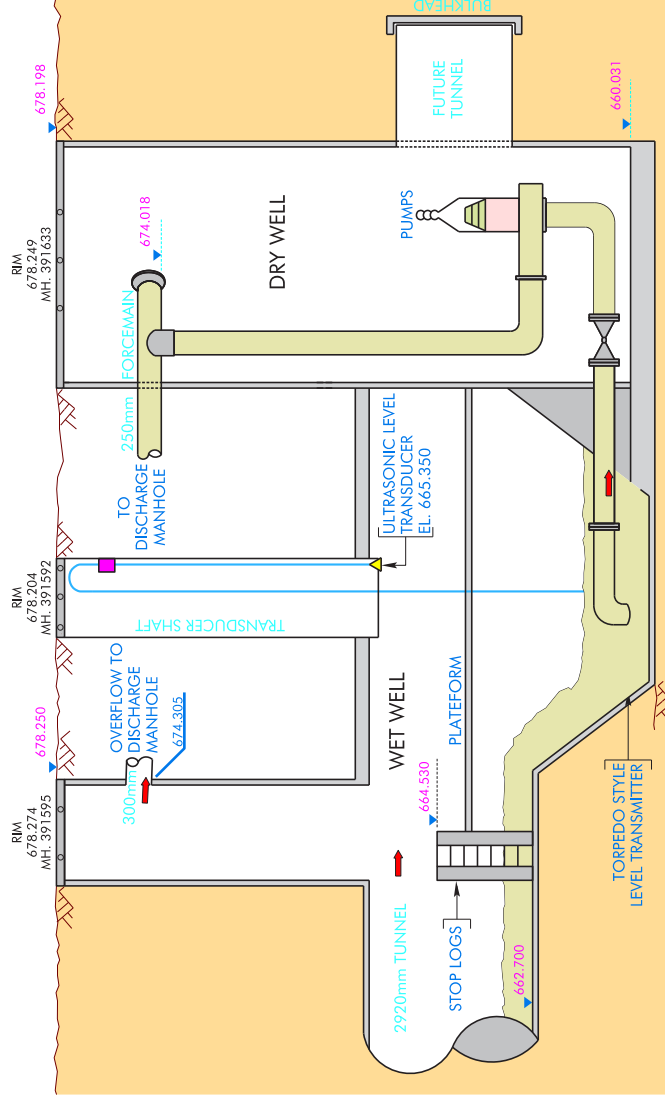

OVERFLOW / DISCHARGE MANHOLE

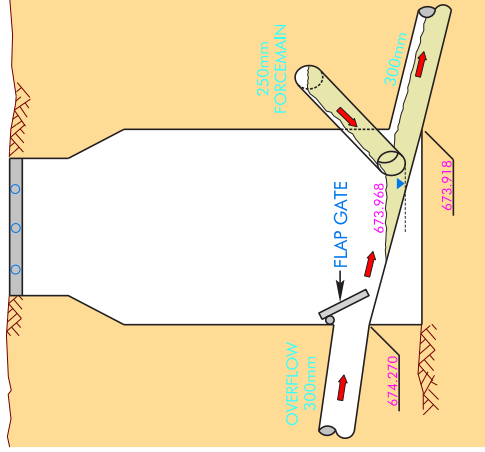

**Pump Sequence:**

- Dry Weather Conditions (High Level Alarm 5795mm, Elevation 666.035m)

**Duty Pump Stops:**

- Upstream Working Level < = 1200mm or Downstream Level > 425mm



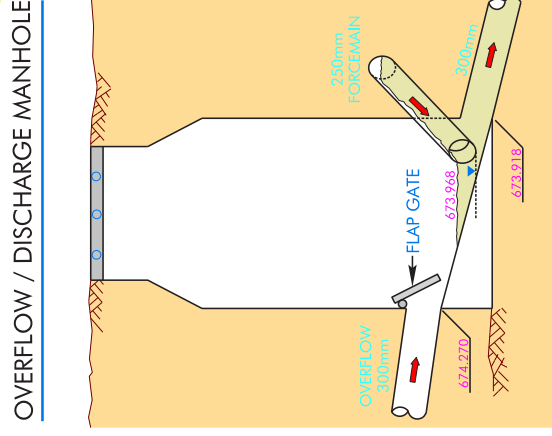
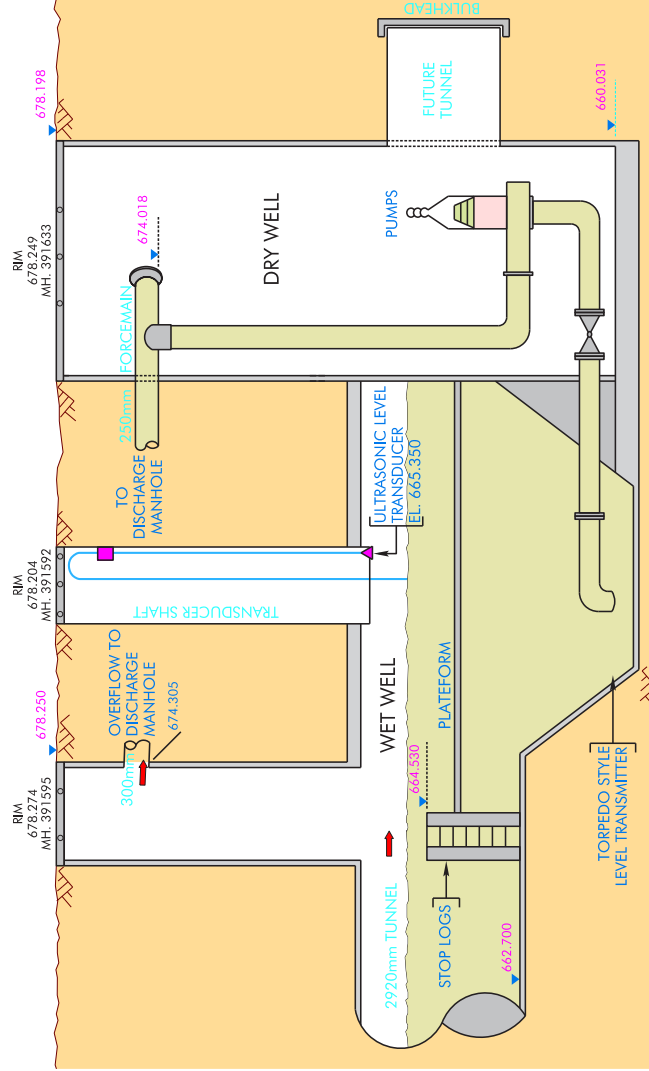

**Pump sequence:**

- Wet Weather Conditions (High Level Alarm 5795mm, Elevation 666.035m)

**Duty Pump Start:**

- Upstream Working Level > 2460mm or Downstream Level < 325mm.

North Edmonton Sanitary Trunk Stage NC1

11410 153 AVENUE

SANITARY LIFT STATION

SEPTEMBER 2019

Page 6

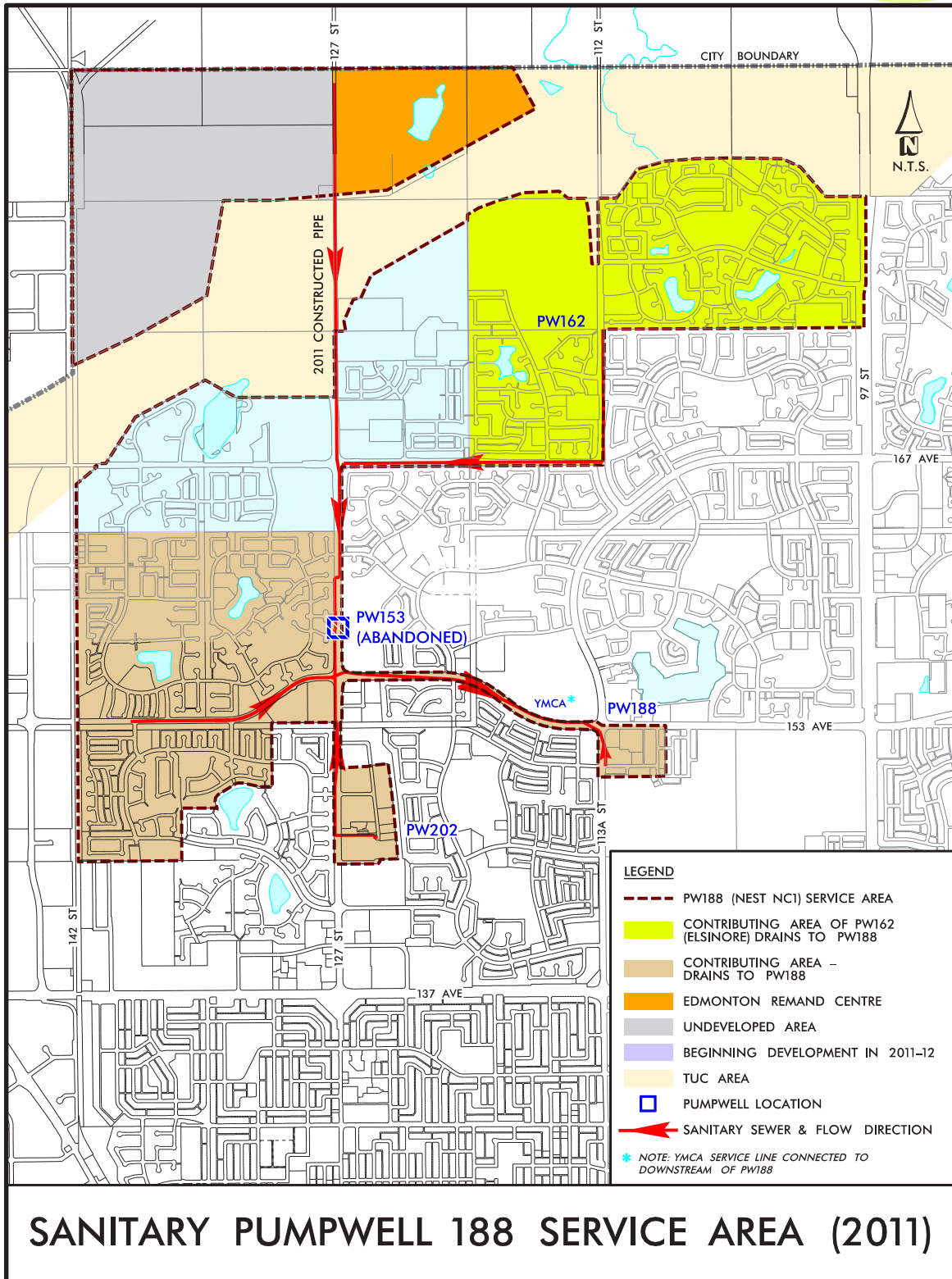

SANITARY PUMPWELL 188 SERVICE AREA (2011)