

NEW APPLICATION

BEFORE THE ARIZONA CORPORATION COMMISSION

COMMISSIONERS

- ROBERT "BOB" BURNS -- Chairman
- BOYD DUNN
- SANDRA D. KENNEDY
- JUSTIN OLSON
- LEA MÁRQUEZ PETERSON

IN THE MATTER OF THE APPLICATION OF)
 EPCOR WATER ARIZONA INC., AN) DOCKET NO.
 ARIZONA CORPORATION, TO EXTEND ITS)
 CERTIFICATE OF CONVENIENCE AND)
 NECESSITY FOR ITS ARIZONA) APPLICATION
 WASTEWATER DISTRICT)
)
)

In accordance with A.R.S. § 40-282 and A.A.C. R14-2-602, EPCOR Water Arizona Inc., an Arizona corporation, ("Company") requests approval from the Arizona Corporation Commission ("Commission") to extend its existing Certificate of Convenience and Necessity ("CC&N") for the Agua Fria area of its Arizona Wastewater District ("Agua Fria") to allow the Company to serve certain properties described below. In support of its Application, the Company states the following:

I. Introduction.

The Company is the largest private water and wastewater utility in Arizona and provides water and wastewater services to approximately 142,000 water customers and 61,000 wastewater customers throughout the state. The Company is a wholly owned subsidiary of EPCOR USA Inc. and was purchased from American Water on February 1, 2012. See Decision No. 72668 (November 17, 2011). The Company is in compliance with all applicable Commission orders, rules and regulations.

The Company requests extension of its certificated service territory to provide wastewater services to a proposed single-family residential subdivision in unincorporated

1 Maricopa County. The proposed development is within the City of Buckeye Municipal
2 Planning Area and within the Maricopa Association of Governments (“MAG”) 208 Plan
3 area of the City of Buckeye Sundance Water Reclamation Facility. The requested extension
4 area is currently without wastewater service.

5 The requested extension area is comprised of 12, contiguous parcels with total area
6 of 184.24 acres. The 12 parcels comprise all properties within the requested extension area
7 and are as follows:

- 8 • 11 parcels owned by Eyherabide Properties, LLC are within the East half of
9 Section 21, Township 2 North, Range 2 West and are identified by Assessor
10 Parcel Numbers (“APN”) 502-29-006S, -006T, -016B, -016D, -016F, -016G, -
11 016H, -024, -025 and -042B. A dairy farm and associated structures are located
12 on these parcels totaling approximately 182.18 acres.
- 13 • One parcel owned by the Vincent and Rose Ann Eyherabide Family Trust is
14 within the Southeast quarter of Section 21, Township 2 North, Range 2 West and
15 is identified by APN 502-29-042A. One residence is located on the
16 approximately 2.06 acre parcel.

17 The Agua Fria area is comprised of three separate wastewater collection systems and
18 three separate water reclamation facilities, including the Company’s Russell Ranch Water
19 Reclamation Facility (“RRWRF”) which serves the Russell Ranch residential community.
20 RRWRF is in proximity to the requested extension area.

21 The Company has received a request for wastewater service from the two property
22 owners. The Company thus proposes to extend its CC&N for the Agua Fria area – and it
23 will also seek to expand its MAG 208 plan area, and to extend the RRWRF collection
24 system to provide wastewater service to the requested extension area. The Preliminary
25
26

1 Sewer Report, attached hereto as Exhibit 4, shows how the RRWRF collection system can
2 be extended to provide service.

3 The Company understands the owners intend to sell their properties to a
4 homebuilder who intends to develop 675 single-family residences within the next six years.
5 No non-residential development is proposed for the requested extension area. The
6 Company believes approving this Application is in the public interest as it will facilitate
7 economic development in the region.

8 Projected infill rates for Russell Ranch and for the requested extension area indicate
9 that RRWRF will have sufficient capacity until early 2023. As the inflow to RRWRF
10 approaches the capacity limit, wastewater discharged from the requested extension area will
11 be diverted from RRWRF and conveyed to the Company's Luke 303 Water Reclamation
12 Facility ("Luke 303"). Luke 303 has an approved design capacity in excess of projected
13 demand and can accept wastewater from the requested extension area.

14 Future customers within the requested extension area will be located in the Agua
15 Fria area of the Arizona Wastewater District and will be charged the rates approved in
16 Decision No. 76162 (June 30, 2017). Extending service to the requested extension area will
17 provide benefits to existing customers including economies of scale, with no additional rate
18 impacts to existing customers.

19 Further, throughout its Arizona Wastewater District, the Company provides safe and
20 reliable wastewater service. Due to the strength of its corporate organization detailed in
21 Decision No. 72668, the Company will be capable of making all investments necessary to
22 ensure safe and reliable wastewater service to future customers, while also maintaining
23 such service to existing customers, at just and reasonable rates. The Company will maintain
24 its ability to attract capital on reasonable terms and to finance day-to-day operations.

25 Approval of this Application will ensure safe and reliable wastewater service to all
26 customers in the requested extension area, in accordance with Commission rules and

1 regulations. The Company is a fit and proper entity to provide wastewater service and it is
2 in the public interest to grant an extension to its CC&N for the Agua Fria area of its
3 Arizona Wastewater District as set forth in this Application.

4 **II. Application.**

5 The Company submits the following information to further support its Application:

6 1. The legal name of the Company, its mailing address, and telephone number
7 are:

8 EPCOR Water Arizona Inc.
9 2355 West Pinnacle Peak Road, Suite 300
10 Phoenix, Arizona 85027
11 (623) 445-2455

12 The Company operates its wastewater utility business under this name.

13 2. The management contact for the Company is Peter M. Ewen, its Director of
14 Regulatory. Mr. Ewen's direct number is (623) 587-5222 and his mailing address is
15 provided in 1, above.

16 3. The Company's attorney responsible for this Application is Jason D.
17 Gellman. Mr. Gellman's direct number is (623) 445-2442 and his mailing address is
18 provided in 1, above.

19 4. All requests for information should be directed to Mr. Ewen with a copy to
20 Mr. Gellman's attention on behalf of the Company. Their email addresses are
21 pewen@epcor.com and jgellman@epcor.com, respectively.

22 5. The Company's operators for the Agua Fria area certified by the Arizona
23 Department of Environmental Quality ("ADEQ"), and currently employed by the
24 Company, are Arthur A. Nunez and Richard E. Schneider. Mr. Nunez's mailing address is
25 15626 N. Del Webb Blvd., Sun City, Arizona 85351, his telephone number is (623) 587-
26 5219 and his Operator ID No. is OP003675. Mr. Schneider's mailing address is 15626 N.

1 Del Webb Blvd., Sun City, Arizona 85351, his telephone number is (623) 445-2484 and his
2 Operator ID No. is OP003364.

3 6. The on-site manager for the Company's Agua Fria area is Richard E.
4 Schneider, whose mailing address and telephone number are provided in 5, above.

5 7. The Company is an Arizona corporation. For federal tax purposes, the
6 Company is structured as a "C" corporation.

7 8. A list of the names, titles, and mailing addresses of all Company officers and
8 directors is attached hereto as Exhibit 1.

9 9. A copy of the Company's "Certificate of Good Standing" is attached hereto
10 as Exhibit 2.

11 10. Because the Company is applying for a CC&N extension, its Articles of
12 Incorporation and By-Laws are not required to be provided with this Application.

13 11. The Company is authorized to issue 600,000 shares of stock. As of July 1,
14 2017, 104,576 shares are issued and outstanding. The last issuance date was August 12,
15 1998.

16 12. The Company does not have an ownership interest in any other utility.

17 13. A description of the requested extension area expressed in metes and bounds
18 is attached hereto as Exhibit 3.

19 14. The requested extension area is located entirely within the City of Buckeye
20 municipal planning area in unincorporated Maricopa County.

21 15. The facilities proposed for construction include an on-site network of
22 collection mains, a wastewater lift station and an off-site force main. A complete
23 description of the facilities proposed for construction is provided in the Preliminary Sewer
24 Report that is attached hereto as Exhibit 4.

25 16. A copy of Aquifer Protection Permit No. 105229 issued by the Arizona
26 Department of Environmental Quality ("ADEQ") for RRWRF is attached as Exhibit 5.

1 17. The estimated total construction cost of the proposed on-site and off-site
2 facilities is \$2,688,285. Documentation to support the estimate is attached hereto as Exhibit
3 6. The proposed facilities will be funded through a combination of developer contributions
4 in aid of construction and advances in aid of construction in accordance with the
5 Company's tariffs and A.A.C. R14-2-606.

6 18. Documentation of the Company's assets and liabilities, an income statement,
7 and the estimated value of the Company's utility plant in service for the first five years
8 following approval of this Application are attached hereto as Exhibit 7.

9 19. A copy of the Company's currently authorized tariff for rates and charges for
10 wastewater service in the Agua Fria area, which the Company plans to implement for
11 service to the requested extension area, is attached hereto as Exhibit 8.

12 20. A schedule of the Company's estimated annual operating revenues and
13 expenses for the first five years of operation for the requested extension area is attached
14 hereto as Exhibit 9. Also included in Exhibit 9 is a description of each assumption made to
15 derive the estimates.

16 21. The proposed wastewater facilities will be constructed in five phases.
17 Phase 1A will include construction of collection sewers in the on-site collector streets, an
18 on-site wastewater lift station and an off-site force main. Phase 1B will be constructed
19 concurrently with Phase 1A and will include collection sewers in the southern portion of
20 the requested extension area. Phases 2, 3 and 4 will include construction of the remaining
21 collection sewers in the northern portion of the requested extension area. Attached hereto as
22 Exhibit 10 are the estimated construction start date and completion date for each phase and
23 the number of single-family residential lots served by sewers installed in each phase.

24 22. A copy of the requests for service received from Eyherabide Properties, LLC
25 and the Vincent and Rose Ann Eyherabide Family Trust is attached hereto as Exhibit 11.

1 23. Maps of the requested extension area, and supporting documentation, are
2 attached hereto as Exhibit 12 and identify the following: (1) boundaries of the area with
3 total acreage; (2) land ownership boundaries of each separately owned parcel within the
4 area and the acreage of each parcel; (3) the owner of each parcel within the area; (4) the
5 municipal corporate limits that overlap or are within five miles of the area; (5) the service
6 areas of wastewater service and water service providers within one mile of the area; (6) the
7 location of the proposed development within the area; (7) the location of the proposed
8 wastewater system within the area; and (8) the location of all parcels for which a copy of a
9 request for service has been received.

10 24. A copy of the notice of application to be sent to the City of Buckeye, the City
11 of Litchfield Park, the City of Glendale, the City of Goodyear, Luke Air Force Base and
12 Maricopa County, and a listing of these entities and their respective mailing addresses, is
13 attached hereto as Exhibit 13.

14 25. All owners of property within the requested extension area have submitted a
15 request for wastewater service to the Company.

16 26. A copy of the Public Service Franchise issued to the Company by Maricopa
17 County is attached hereto as Exhibit 14. If the City of Buckeye incorporates the requested
18 extension area within its boundaries, and if the City requires the Company to enter into a
19 franchise agreement, the Company will do so and will provide a copy of that agreement to
20 the Commission upon receipt. Copies of all other municipal, county and state agency
21 approvals required to construct or operate water facilities in the requested extension area
22 will be provided to the Commission up receipt.

23 27. The table, below, identifies the estimated number of residential customers in
24 the requested extension area to be served for each of the first five years of operation. No
25 non-residential customers will be served in the requested extension area. Documentation to
26

1 support the estimate is provided in the Preliminary Sewer Report attached hereto as Exhibit
2 4.

Year of Operation	Number of Residential Customers
1	50
2	218
3	386
4	554
5	675

3
4
5
6
7
8
9 28. The requested extension area is within the Arizona Water Company White
10 Tank water service area. The Company understands that the facilities of the Arizona Water
11 Company will be extended into the requested extension area to provide water service.

12 29. Wastewater discharged from the requested extension area will be conveyed to
13 the RRWRF for treatment and subsequently discharged to groundwater recharge basins
14 located at that facility. Biosolids are transported to the Company's Verrado Water
15 Reclamation Facility ("Verrado WRF") for solids handling.

16 30. A copy of a request for the current compliance status reports from ADEQ for
17 each wastewater system operated by the Company is attached hereto as Exhibit 15.

18 31. A wastewater flow data sheet for the system being extended for the period
19 from January 2019 to April 2020 is attached hereto as Exhibit 16.

20 32. The notarized signature of management contact Peter M. Ewen, signing on
21 behalf of the Company, is attached as Exhibit 17 to this Application.

22 WHEREFORE, the Company respectfully requests that the Commission:

23 (1) Approve its Application, after notice and opportunity to be heard, in accordance
24 with A.A.C. R14-2-610(C);

25 (2) Grant the Company additional relief as the Commission deems just and proper.

26 RESPECTFULLY SUBMITTED this 20th day of October, 2020.

EPCOR WATER ARIZONA INC.

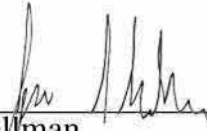

Jason D. Gellman
2355 West Pinnacle Peak Road, Suite 300
Phoenix, AZ 85027

Attorney for EPCOR Water Arizona Inc.

1
2
3
4
5
6
7
8
9
10
11
12
13
14
15
16
17
18
19
20
21
22
23
24
25
26

1 Copies of the foregoing
2 efiled this 20th day
3 of October, 2020, with;

4 Docket Control
5 Arizona Corporation Commission
6 1200 W. Washington Street
7 Phoenix, Arizona 85007

8 Jane Rodda, Esq.
9 Chief Administrative Law Judge
10 Hearing Division
11 Arizona Corporation Commission
12 1200 W. Washington Street
13 Phoenix, Arizona 85007

14 Robin R. Mitchell, Esq.
15 Legal Division Chief Counsel/Division Director
16 Arizona Corporation Commission
17 1200 W. Washington Street
18 Phoenix, Arizona 85007

19 Elijah Abinah
20 Director, Utilities Division
21 Arizona Corporation Commission
22 1200 W. Washington Street
23 Phoenix, Arizona 85007

Exhibits

- 1
- 2 Exhibit 1 Company Officers and Directors
- 3 Exhibit 2 Certificate of Good Standing
- 4 Exhibit 3 Legal Description – Extension Area
- 5
- 6 Exhibit 4 Preliminary Sewer Report
- 7 Exhibit 5 Aquifer Protection Permit
- 8 Exhibit 6 Estimated Total Construction Costs
- 9 Exhibit 7 Financial Statement
- 10
- 11 Exhibit 8 Authorized Tariffs
- 12 Exhibit 9 Estimated Annual Operating Revenue and Expenses
- 13 Exhibit 10 Proposed Construction Timeline
- 14 Exhibit 11 Request for Service Letter
- 15
- 16 Exhibit 12 Maps of Requested Extension Area
- 17 Exhibit 13 Proposed Form of Notice and Mailing List
- 18 Exhibit 14 Franchise Agreement
- 19 Exhibit 15 ADEQ Compliance Status Reports
- 20
- 21 Exhibit 16 Wastewater Flow Data Sheet
- 22 Exhibit 17 Affidavit
- 23
- 24
- 25
- 26

Exhibit 1
Company Officers and Directors

2020 ANNUAL REPORT

ENTITY INFORMATION

ENTITY NAME: EPCOR WATER ARIZONA INC.
ENTITY ID: 00420990
ENTITY TYPE: Domestic For-Profit (Business) Corporation
CHARACTER OF BUSINESS: UTILITIES
AUTHORIZED SHARES: Share Class: COMMON Share Series: Share Total: 600000
ISSUED SHARES: Share Class: 104576 Share Series: N/A Share Total: 104576

STATUTORY AGENT INFORMATION

STATUTORY AGENT NAME: C T CORPORATION SYSTEM
PHYSICAL ADDRESS: 3800 N CENTRAL AVE SUITE 460 , PHOENIX, AZ 85012
MAILING ADDRESS: 3800 N CENTRAL AVE SUITE 460 , PHOENIX, AZ 85012

KNOWN PLACE OF BUSINESS

Att: THOMAS A. LOQUVAM, 2355 W PINNACLE PEAK RD SUITE 300 , PHOENIX, AZ 85027

PRINCIPAL OFFICE ADDRESS

PRINCIPAL INFORMATION

Director: GREGORY BARBER - 2355 W PINNACLE PEAK RD #300, PHOENIX, AZ, 85027, USA - - Date of Taking Office: 12/11/2017

Director: JOSEPH GYSEL - 2355 W PINNACLE PEAK RD #300, PHOENIX, AZ, 85027, USA - - Date of Taking Office: 02/01/2012

Other Officer: GREGORY BARBER - 2355 W PINNACLE PEAK RD SUITE 300, PHOENIX, AZ, 85027, USA - - Date of Taking Office: 04/10/2018

Other Officer: JASON GELLMAN - 2355 W PINNACLE PEAK RD SUITE 300, PHOENIX, AZ, 85027, USA - - Date of Taking Office: 12/31/2019

President: JOSEPH GYSEL - 2355 W PINNACLE PEAK RD #300, PHOENIX, AZ, 85027, USA - - Date of Taking Office: 02/01/2012

Secretary: THOMAS A. LOQUVAM - 2355 W PINNACLE PEAK RD SUITE 300, PHOENIX, AZ, 85027, USA - kstanley@epcor.com - Date of Taking Office: 12/31/2019

Shareholder: EPCOR USA INC. - 2355 W PINNACLE PEAK ROAD, SUITE 300, PHOENIX, AZ, 85027, USA - - Date of Taking Office: 12/31/9999

Treasurer: GREGORY BARBER - 2355 W PINNACLE PEAK RD SUITE 300, PHOENIX, AZ, 85027, USA - - Date of Taking Office: 04/10/2018

SIGNATURE

Secretary: THOMAS A. LOQUVAM - 01/20/2020

Exhibit 2
Certificate of Good Standing

STATE OF ARIZONA



**Office of the
CORPORATION COMMISSION**

CERTIFICATE OF GOOD STANDING

I, the undersigned Executive Director of the Arizona Corporation Commission, do hereby certify that:

EPCOR WATER ARIZONA INC.

ACC file number: 00420990

was incorporated under the laws of the State of Arizona on 12/30/1949;

That all annual reports owed to date by said corporation have been filed or delivered for filing, and all annual filing fees owed to date have been paid; and

That, according to the records of the Arizona Corporation Commission, said corporation is in good standing in the State of Arizona as of the date this Certificate is issued.

This Certificate relates only to the legal existence of the above named entity as of the date this Certificate is issued, and is not an endorsement, recommendation, or approval of the entity's condition, business activities, affairs, or practices.

IN WITNESS WHEREOF, I have hereunto set my hand, affixed the official seal of the Arizona Corporation Commission, and issued this Certificate on this date: **09/21/2020**



Matthew Neubert

Matthew Neubert, Executive Director

Exhibit 3
Legal Description – Extension Area



Extension Area

Legal Description Fulton Homes Enclave

Job No. 19-0254

March 2, 2020

A portion of East Half of Section 21, Township 2 North, Range 2 West, of the Gila and Salt River Meridian, Maricopa County, Arizona, and more particularly described as follows:

BEGINNING at a 3" C.O.G. brass cap in a hand hole at the southeast corner of said Section 21, from which a 3" C.O.G. brass cap in a hand hole at the south quarter corner of said Section 21, bears North 89 degrees 20 minutes 44 seconds West (an assumed bearing) at a distance of 2,649.31 feet;

thence North 89 degrees 20 minutes 44 seconds West, along the south line of the Southeast Quarter of said Section 21, 2574.31 feet to a point on the east line of the west 75.00 feet of said East Half;

thence North 0 degrees 30 minutes 45 seconds East, along said east line, 2626.82 feet;

thence continuing along said east line, North 0 degrees 30 minutes 45 seconds East, 659.08 feet to a point on the north line of the South Half of the Southwest Quarter of the Northeast Quarter of said Section 21;

thence South 89 degrees 35 minutes 47 seconds East, along said north line, 1245.94 feet to the northeast corner of the South Half of the Southwest Quarter of the Northeast Quarter of said Section 21;

thence South 0 degrees 26 minutes 53 seconds West, along the east line of the South Half of the Southwest Quarter of the Northeast Quarter of said Section 21, 329.61 feet to the northwest corner of the South Half of the South Half of the Southeast Quarter of the Northeast Quarter of said Section 21;

thence South 89 degrees 35 minutes 36 seconds East, along the north line of the South Half of the South Half of the Southeast Quarter of the Northeast Quarter of said Section 21, 1321.31 feet to the northeast corner of the South Half of the South Half of the Southeast Quarter of the Northeast Quarter of said Section 21, said point being on the east line of the Northeast Quarter of said Section 21;

thence South 0 degrees 23 minutes 02 seconds West, along said east line, 329.68 feet to the east quarter corner of said Section 21;

thence South 0 degrees 23 minutes 00 seconds West, along the east line of the Southeast Quarter of said Section 21, 2637.80 feet to the POINT OF BEGINNING.



Containing an area of 8,025,650 square feet or 184.2436 acres, more or less.



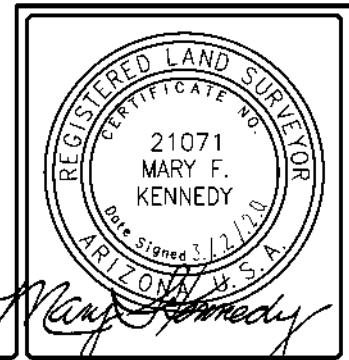
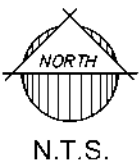
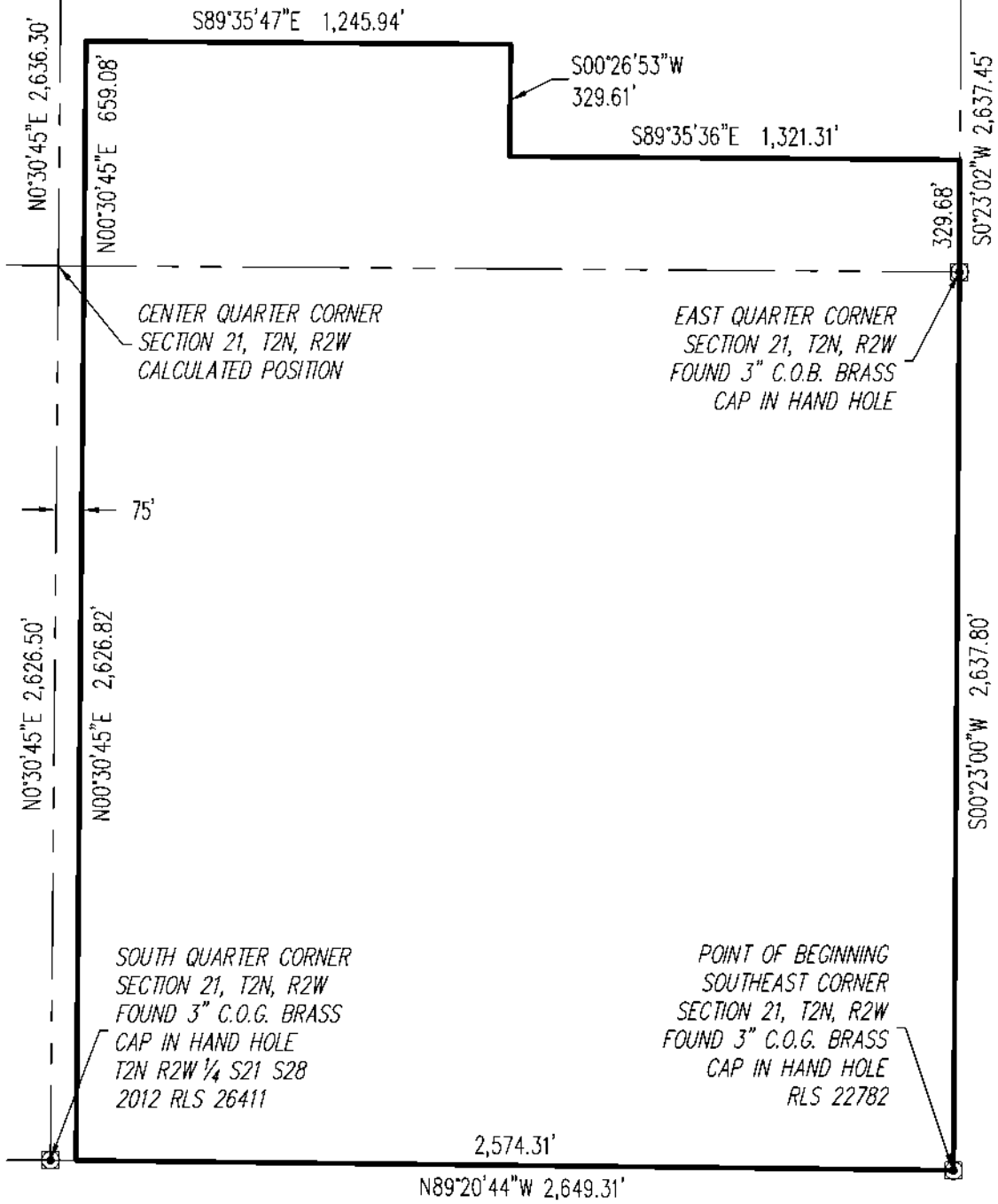

19-0254	Fulton Homes Enclave	 <p>1130 N. Alma School Rd. Ste. 120 Mesa, AZ 85201 T:480.503.2250 F:480.503.2258 www.epsgroupinc.com</p>
	EXHIBIT	

Exhibit 4
Preliminary Sewer Report



Preliminary Sewer Report

For

Fulton Homes Enclave

Maricopa County, Arizona

Prepared for:

Owner/Developer

Fulton Homes Corporation
9140 S. Kyrene Road Ste 202
Tempe, Arizona 85284
(480) 753-6789
Contact: Norm Nicholls

Prepared by:

Civil Engineer

EPS Group Inc.

1130 N. Alma School Road, Suite 120
Mesa, Arizona 85201
Tel: (480) 503 - 2250
Contact: Brian Nicholls



Project No. 19-0254

Date: June 2020

1130 N Alma School Road, Suite 120
Mesa, Arizona 85201
o: 480.503.2250
f: 480.503.2258
epsgroupinc.com

Table of Contents

1.0	Introduction	1
2.0	Design Documentation.....	1
3.0	Existing Conditions.....	1
4.0	Proposed Conditions	1
5.0	Computations and Design Documentation.....	2
5.1	Calculations:.....	4
6.0	Construction Phasing.....	4
6.1	Financing.....	5
7.0	Conclusions.....	6
8.0	References.....	6

Appendix

Appendix A.....	Figures: Vicinity Map, Overall Sewer Model, Service Map & Phasing Plan, Boundary & Corporate Limits Map, Boundary & Land Ownership Map
Appendix B.....	Sewer Calculations
Appendix C.....	Estimated Total Construction Costs
Appendix D.....	Legal Description
Appendix E.....	Request for Service Letter



1.0 Introduction

Fulton Homes Enclave (the Project) is an approximately 184.24 gross acre project of 675 single-family residential homes. The project is generally bounded by existing 1-acre residential lots to the north, Indian School Road to the south, Perryville Road to the east, and the Beardsley Canal to the west. The project is located in Section 21, Township 2 North, Range 2 West of the Gila and Salt River Base and Meridian in Maricopa County, Arizona. See Appendix A, Figure 1: Vicinity Map.

The Project will include four different typical lot sizes: 45' x 115', 50' x 120', 55 x 120', and 63' x 125', with minimum lot areas ranging between 5,175 SF and 7,875 SF. The inclusion of four lot sizes will allow for a range and diversity in anticipated housing product throughout the Community.

This preliminary sewer report will evaluate wastewater characteristics within the project. Design parameters from the Maricopa County and EPCOR Design Criteria for Wastewater Systems from the EPCOR Water 2015 Developer and Engineering Guide will be applied to this proposed project to ensure adherence to regulations. A more detailed and final analysis of the wastewater system will be provided during the final engineering stage of this project.

2.0 Design Documentation

All wastewater facilities for this project will be designed in accordance with the latest EPCOR Design Criteria for Wastewater Systems, Maricopa County Environmental Services requirements, MAG standards/specifications, and ADEQ Engineering Bulletin No. 11, "Minimum Requirements for Design, Submission of Plans and Specifications of Sewage Works."

3.0 Existing Conditions

The Project site is currently an operating dairy and farm, bounded by the Beardsley Canal, an organic farm, and residential development. The site has a slight existing slope of approximately 1% from the northwest to the southeast.

4.0 Proposed Conditions

Wastewater service for the Project is anticipated to be provided by EPCOR, even though the Site is currently within the City of Buckeye's planning area. The nearest sewer main of the City of Buckeye was not designed to receive sewage from the Project and there has not been any discussion about the Buckeye Sewer System to be extended in order to accommodate the Fulton Homes Enclave site as a part of the City of Buckeye's overall sewer design. Furthermore, the area's topography and

the depth of the City's closest sewer main make a gravity sewer connection to the City's wastewater system not feasible.

A network of 8-inch onsite sewer mains will convey wastewater flows from each lot to the southeast corner of the Project. At the southeast corner, the 8-inch sewer mains connect to a 10-inch sewer main, approximately 70-feet in length, which connects the entire onsite sewer system to the lift station. See Appendix A, Figure 2: Overall Sewer Model. The lift station is being designed to allow wastewater to flow north along Perryville Road to Camelback Road.

From Perryville Road, the force main will extend eastward, along the north side of Camelback Road to the intersection of 181st Avenue. From there, it will flow north within 181st Avenue and tie into an EPCOR Gravity Sewer manhole and join the flows going into the Russell Ranch Water Reclamation Facility. The force main is approximately 9,565-feet in length, see Figure 3: Service Map & Phasing Plan, Appendix A.

5.0 Computations and Design Documentation

Wastewater flow computations for Fulton Homes Enclave have been based on the EPCOR Design Criteria for Wastewater Systems, Tables 1 and 2, of the EPCOR Water 2015 Developer and Engineering Guide, this project assumes 100 gallon per person per day at 2.4 person per dwelling unit (240 gallons per unit per day).

The overall sewer network is shown in Appendix A, Figure 2. Minimum cover of 6-feet is required for sewer lines of 12-inches or less, and sewer service lines will have a minimum of 5-feet of cover at the property line. Pipe slope, velocity, and capacity are all designed per EPCOR Design Criteria for Wastewater Systems, Table 2, which specifies minimum slopes:

- 8" sewer pipes must have a minimum slope of 0.00368 ft/ft (0.368%)
- 10" sewer pipes must have a minimum slope of 0.0030 ft/ft (0.30%)
- 12" sewer pipes must have a minimum slope of 0.00257 ft/ft (0.257%)

The maximum flow velocity for sewer is 9.0 ft/s, therefore the maximum pipe slopes are:

- 0.0676 ft/ft (6.76%) for 8" sewer pipes
- 0.05020 (5.020%) for 10" sewer pipes
- 0.03937 (3.937%) for 12" sewer pipes

Design flows and peaking factors are calculated per the EPCOR Water 2015 Developer and Engineering Guide, which states the peaking factor is (3.0) for all sewer lines.

A network summary table is included in Appendix B, which calculates the demand for the Project. Peak wastewater production for Fulton Homes Enclave will be 486,000 gallons per day which will be deposited into the lift station.

EPCOR Design Standard Summary:

Table 1 – Average Daily Waste Water Design Flows

Land Use	Unit	Average Daily Flow (gal/day/unit)	Peak Hour Peaking Factor
Single Family	Dwelling	240	3.0
Commercial ¹	Acre	1500	3.0

¹Acreage is based on gross number of acres.

Table 2 – EPCOR Design Standard – Minimum/ Maximum Slopes (Manning’s Roughness Coefficient of 0,013)

Pipe Diameter (inches)	Minimum Slope (%)	Minimum Velocity (ft/sec)	Maximum Slope (%)	Maximum Velocity (ft/sec)
8	0.368	2.1	6.670	9
10	0.300	2.2	5.020	9
12	0.257	2.3	3.937	9

Manhole spacing and sizing is designed per EPCOR Design Criteria for Wastewater Systems, which states the maximum manhole spacing is 500 feet. The Enclave wastewater system does not include any irregular structures or wash crossings. the EPCOR Water 2015 Developer and Engineering Guide also describes the manhole sizing requirements.

It is typical that a 4-foot diameter manhole is used on sewers that are up to 10-feet deep (flow line to rim). If the sewer is greater than 10-feet deep (flow line to rim), a 5-foot diameter manhole is required. A 5-foot diameter manhole is required for mains that are 15-inch diameter or larger. If a manhole has a sewer direction change that is less than 45 degrees, the design should accommodate a 0.1-foot drop across the manhole. If the manhole has a sewer direction change that is greater than 45

degrees, the design should accommodate a 0.2-foot drop across the manhole. All manholes will have a 30-inch frame and cover.

All manhole rims must be above the 100-year floodplain elevation. Water tight manhole covers are required where covers are located within 2 feet of the edge of a gutter, in areas that are unpaved, and in areas that are prone to flooding. Rim elevations should be set 0.2 feet above finish grade in all unpaved areas and a minimum of 18-inches above finish grade in washes.

Flow velocity and pipe capacity are calculated based on a depth to diameter ratio (d/D) of 0.75 max in peak hour flow conditions. Flow velocities are greater than 2 feet per second, flowing full, and are based on the geometry of the pipe rather than the actual flows in the pipe. All pipes in the system are shown to have capacity for the design flows they will carry.

5.1 Calculations:

Average Daily Flow and Peak Flow Calculations:

Flow Through Fulton Homes Enclave Single Family Residences =

$675 \text{ Lots} \times 2.4 \text{ persons/du.} = 1620 \times 100 \text{ gal/day} = 162,000 \text{ gal/day} \times 3.0 \text{ P. F.}$

Peak Hour Demand Calculations:

$162,000 \text{ gal/day} \times 3.0 \text{ P. F.} = 486,000 \text{ GPD}$

6.0 Construction Phasing

The Project will be constructed in 5 Phases, beginning with Phase IA, which includes Indian School Road improvements, onsite collector roads, as well as the lift station and all of the offsite force main line along Perryville Road from the lift station north to Camelback Road, then east to the EPCOR facility. Phase IB completes the local roads and lots in the southern half of the Project, Phases 2, 3, and 4 will complete the development in the northern half of Fulton Homes Enclave site. See Figure 3: Service Map & Phasing Plan, Appendix A.

It is assumed that 675 customers will be served in this community within the first 5 years of operation which will be all 675 lots of the Fulton Homes Enclave project.

Construction is estimated to begin July 1, 2021 and the last phase is scheduled to be completed on January 1, 2023.

Table 3 – Estimated Construction Timeline, by Phase

Phase	Number of Lots	Start Date	Completion Date
1A	24	July 1, 2021	October 1, 2021
1B	234	July 1, 2021	October 1, 2021
2	151	October 1, 2021	January 1, 2022
3	172	January 1, 2022	October 1, 2022
4	94	July 1, 2022	January 1, 2023

6.1 Financing

The construction costs of both the required on-site sewer facilities and off-site sewer facilities (lift station and force main) will be financed by developer and constitute an advance in aid of construction subject to refund from utility to the developer per Arizona Administrative Code R14-2-606, pursuant to a line extension agreement(s) to be entered into by and between developer and utility.

7.0 Conclusions

This basis of design report has shown:

- The average daily amount of wastewater that will be generated by Fulton Homes Enclave is 486,000 GPD.
- Total length of 8-inch Sewer Line proposed for the site is 26,312 LF.
- Total length of 10-inch Sewer Line proposed for the site is 70 LF.
- Total length of 6-inch Force Main is 9,565 LF.
- Total number of 4-foot Diameter Manholes with 30-inch cover is 89.
- The collection system designed for the Project is capable of handling the calculated design flows for Fulton Homes Enclave.
- The sewer collection network meets the applicable design criteria.
- A lift station will be necessary to transfer wastewater from the site to the EPCOR gravity sewer main at the northwest corner of Camelback Road and 181st Avenue. From there, the waste will continue east along Camelback road to EPCOR's Russell Ranch Water Reclamation Facility for treatment.
- Construction will be completed in 5 phases (Phase 1A – 24 lots, 1B – 234 lots, 2 – 151 lots, 3 – 172 lots, and 4 – 94 lots).
- Construction is estimated to begin July 1, 2021 with Phases 1A and 1B and all phases are scheduled to be completed by January 1, 2023.

8.0 References

- EPCOR Design Criteria for Wastewater Systems from the EPCOR Water 2015 Developer and Engineering Guide
- EPCOR Detail 100-4: Sewer System Material Specification; January 2019
- ADEQ Engineering Bulletin No. 11: Minimum Requirements for Design, Submission of Plans and Specifications of Sewage Works, July 1978

https://legacy.azdeq.gov/function/forms/download/list/Engineering_Bulletin_No_11_Minimum_Requirements_for_Design_Submission_of_Plans_and_specifications_of_Sewage_Works_July_78.PDF

Appendix A

Figures

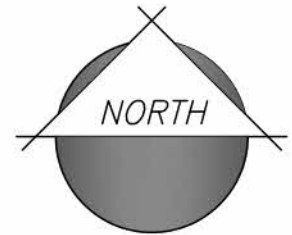

N.T.S.

19-0254

Fulton Homes Enclave
Maricopa County, Arizona

Figure 1: Vicinity Map



1130 N. Alma School Rd
Suite 120 Mesa, AZ 85201
T:480.503.2250 | F:480.503.2258
www.epsgroupinc.com

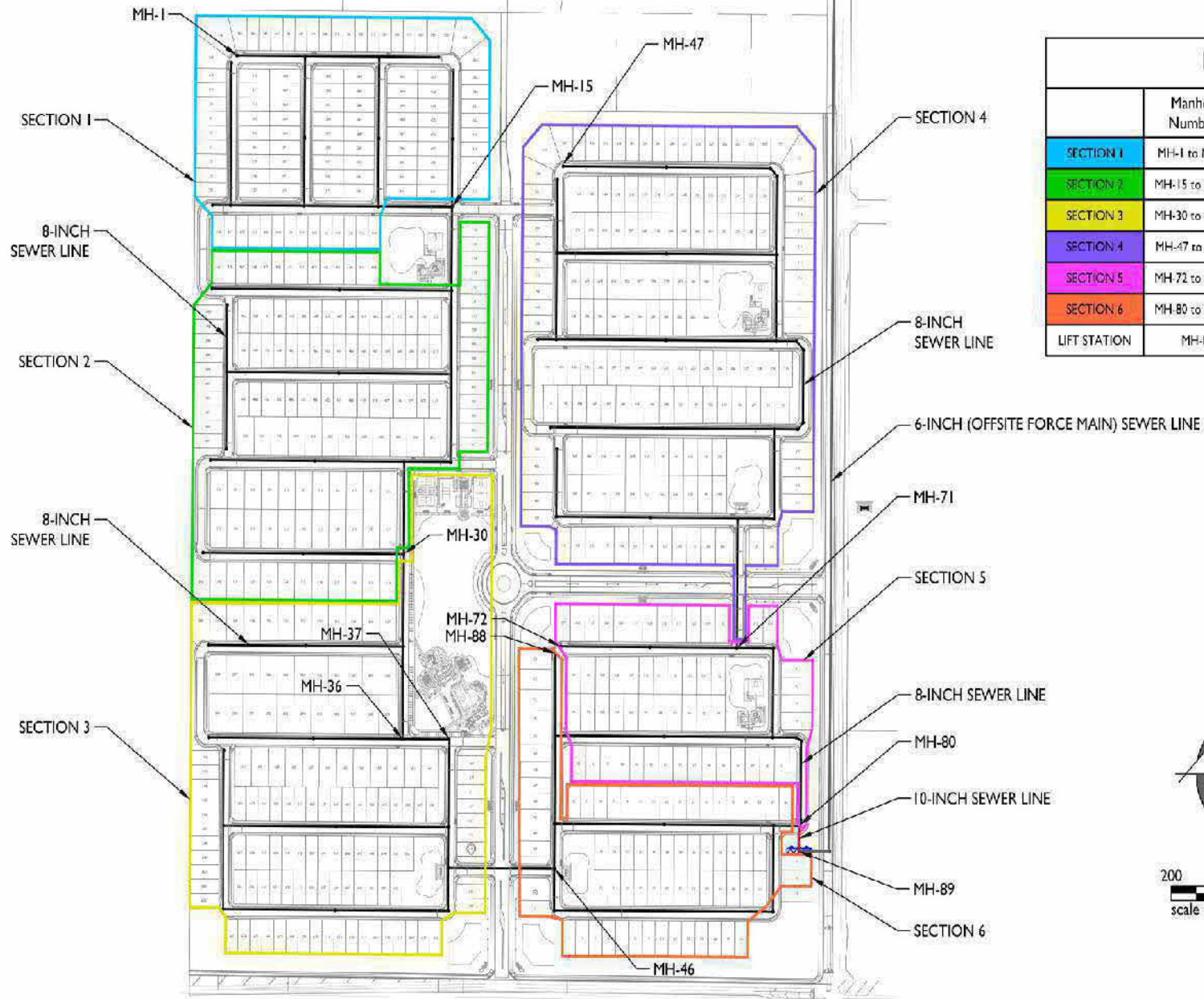

Legend			
	Manhole Numbers	Total Length (ft) 8" Sewer Line	Number of Lots
SECTION 1	MH-1 to MH-15	3708'	108
SECTION 2	MH-15 to MH-30	4466'	137
SECTION 3	MH-30 to MH-46	5697'	130
SECTION 4	MH-47 to MH-71	7014'	172
SECTION 5	MH-72 to MH-80	2432'	55
SECTION 6	MH-80 to MH-88	2995'	73
LIFT STATION	MH-89	70' (10" Sewer Line)	-

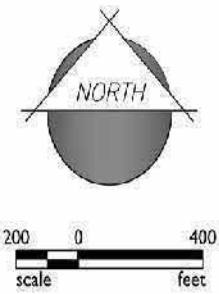

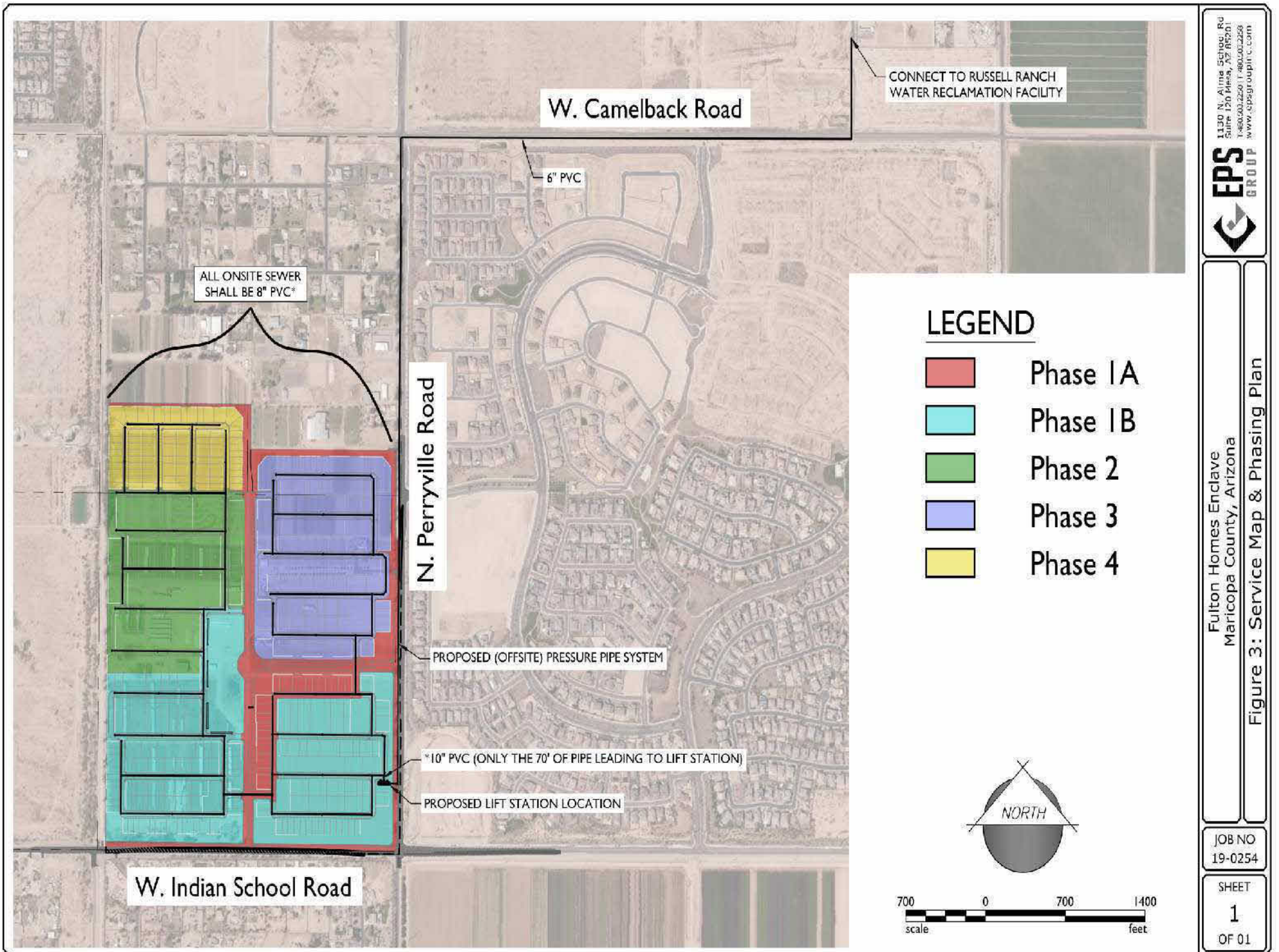

CONNECT TO RUSSELL RANCH WATER RECLAMATION FACILITY

W. Camelback Road

6" PVC

ALL ONSITE SEWER SHALL BE 8" PVC*

N. Perryville Road

LEGEND

- Phase 1A
- Phase 1B
- Phase 2
- Phase 3
- Phase 4

PROPOSED (OFFSITE) PRESSURE PIPE SYSTEM

*10" PVC (ONLY THE 70' OF PIPE LEADING TO LIFT STATION)

PROPOSED LIFT STATION LOCATION

W. Indian School Road

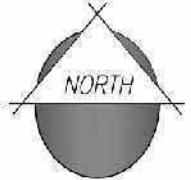

1130 N. Alma School, Ru
Suite 120 Mesa, AZ 85201
T-480.002.2250 F-480.002.2258
www.epsgroupinc.com



Fulton Homes Enclave
Maricopa County, Arizona

Figure 3: Service Map & Phasing Plan

JOB NO
19-0254

SHEET
1
OF 01

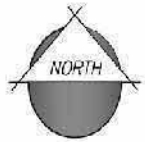

2500 0 5000
scale feet

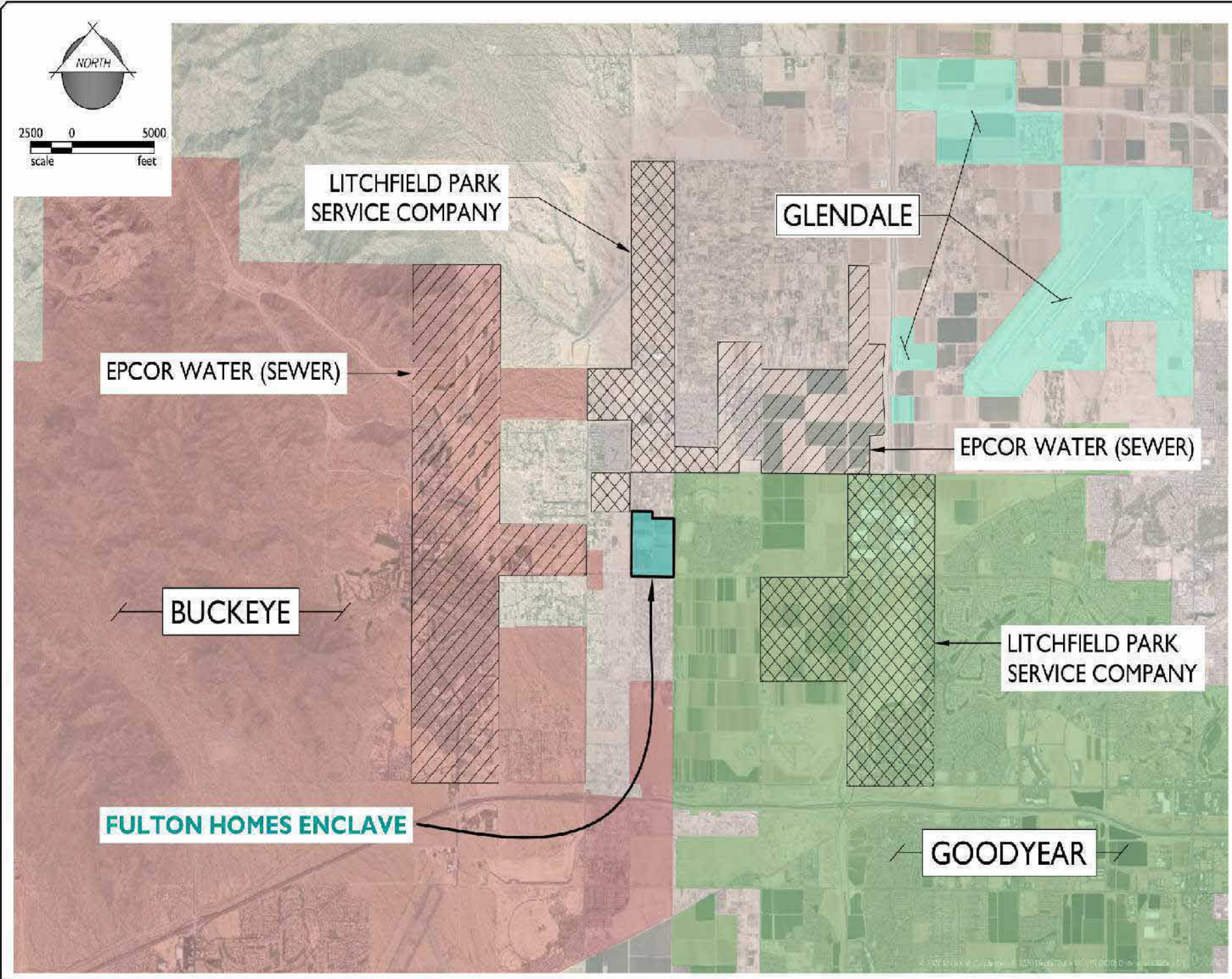

1130 N. Alma School, Ru
Suite 120 Mesa, AZ 85201
T: 480.001.2260 F: 480.001.2268
www.epsgroupinc.com



Fulton Homes Enclave
Maricopa County, Arizona
Figure 4: Boundary & Corporate Limits Map

JOB NO
19-0254

SHEET
1
OF 01

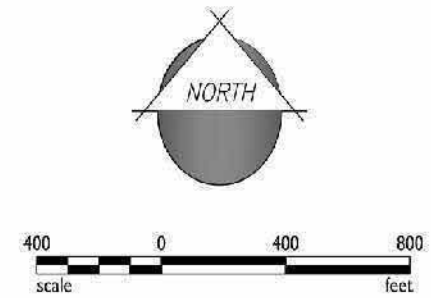
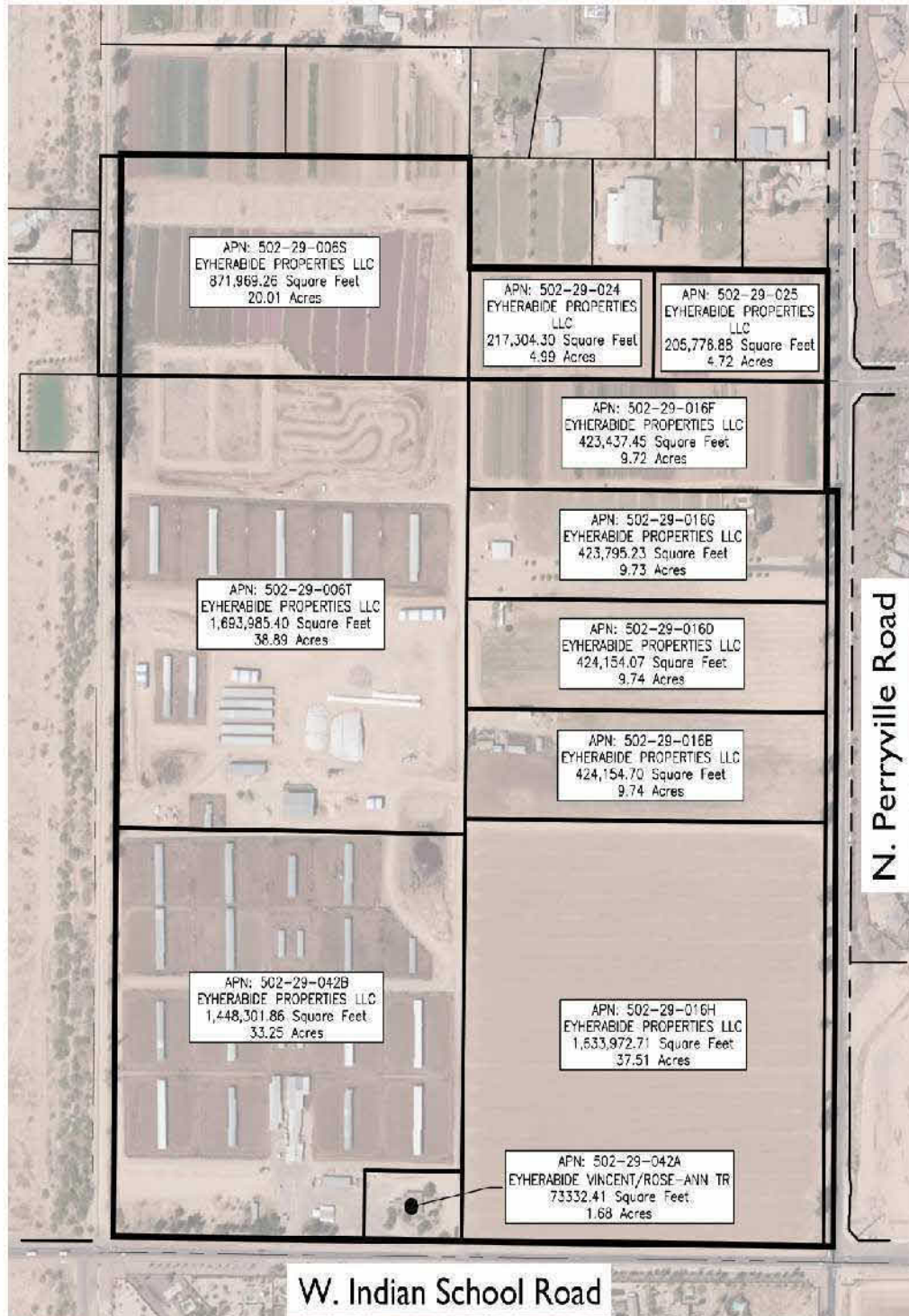

1130 N. Alma School Rd
Suite 120 Mesa, AZ 85201
T: 480.902.2250 F: 480.902.2258
www.epsgroupinc.com



Fulton Homes Enclave
Maricopa County, Arizona

Figure 5: Boundary & Land Ownership Map

JOB NO
19-0254

SHEET
1
OF 01

Appendix B

Sewer Calculations

Average Daily Sewer Flows and Pipe Capacity Using Manning's Equation

Project: 19-0254 - Fulton Homes Enclave

Prepared by: Cassie Farwell

Date: 2/26/2020

Calculations Assume 100 GPD/capita

Calculations Assume 2.4 Persons/D.U.

Calculations Assume 1,500 GPD/acre

Sewer Pipe Information					Additional Flow Information				Peak Demand Information					Full Flow Check		Non-Pressurized Flow Calculations					
Sewer Reach	Length (ft)	Pipe Diameter (in)	Slope (ft/ft)	Manning's Roughness	Description	Additional Contributing Lots	Other Additional Contributing Flow (GPD)	Additional Upstream Flow (GPD)	Cumulative Daily Flow (GPD)	Equivalent Population	Peaking Factor	Peak Demand (GPD)	Peak Demand (MGD)	Peak Demand (cfs)	Full Flow Capacity (cfs)	Pressurized Flow?	Theta of flow (rad)	Depth of Flow (ft)	Percent Full (d/D)	Area of Flow (ft ²)	Wetted Perimeter of flow (ft)
MH-1 - MH-15	1366	8	0.00368	0.013	Section 1 to Section 2	108			25,920	259	3.00	77,760	0.07776	0.120	0.74	NO	2.20	0.19	27%	0.0775	0.734
MH-15 - MH-30	2032	8	0.00368	0.013	Section 2 to Section 3	137		25,920	58,800	586	3.00	176,400	0.176	0.273	0.74	NO	2.83	0.29	42%	0.1400	0.943
MH-30 - MH-46	1661	8	0.00368	0.013	Section 3 to Section 6	130		58,800	90,000	900	3.00	270,000	0.270	0.418	0.74	NO	3.30	0.36	54%	0.1923	1.100
MH-36 - MH-37	187	8	0.00368	0.013	Amenities/ Pool Area		9,172	90,000	99,172	992	3.00	297,516	0.298	0.460	0.74	NO	3.44	0.38	57%	0.2071	1.146
MH-47 - MH-71	2791	8	0.00368	0.013	Section 4 to Section 5	172			41,200	413	3.00	123,640	0.124	0.192	0.74	NO	2.53	0.23	35%	0.1002	0.842
MH-72 - MH-80	1561	8	0.00368	0.013	Section 5 to Lift Station	55		41,200	54,480	545	3.00	163,440	0.163	0.253	0.74	NO	2.76	0.27	40%	0.1324	0.919
MH-86 - MH-80	2119	8	0.00368	0.013	Section 6 to Lift Station	73		99,172	116,892	1,167	3.00	350,076	0.350	0.542	0.74	NO	3.70	0.43	64%	0.2352	1.234
MH-80 - MH-89	70	10	0.00300	0.013	Lift Station to Offsite		54,400	116,692	171,172	1,712	3.00	513,516	0.514	0.795	1.20	NO	3.52	0.49	59%	0.3371	1.465

Notes:

Appendix C

Estimated Total Construction Costs

Engineer's Estimate of Probable Cost

Project Name: Fulton Homes Enclave
Project Phase: Construction Documents
EPS Project No.: 19-0254
Date: 6/24/2020



Description	Unit Price	Quantity	Unit	Cost
Sewer Infrastructure Improvements				
6" PVC Force Main (Class 300)	\$ 35.00	9,179	LF	\$ 321,265.00
8" PVC (SDR-35) Sewer Pipe	\$ 39.00	26,312	LF	\$ 1,026,168.00
10" PVC (SDR-35) Sewer Pipe	\$ 44.00	70	LF	\$ 3,080.00
4' Sewer Manhole w/30" cover; MAG 420-1,423-2	\$ 4,300.00	89	EA	\$ 382,700.00
Sewer Testing	\$ 5.00	35,561	LF	\$ 177,805.00
Lift Station	\$ 330,477.50	1	LS	\$ 330,477.50
Sawcut Pavement, Remove, and Replace pavement in kind	\$ 25.00	796	SY	\$ 19,900.00
Combination Air/Vacuum Sewage Release Valve	\$ 5,000.00	1	EA	\$ 5,000.00
Connection to Ex. Manhole	\$ 4,500.00	1	EA	\$ 4,500.00
Sewer Vertical Realignment	\$ 1,500.00	2	EA	\$ 3,000.00
Jack & Jack w/ Casing	\$ 1,000.00	20	LF	\$ 20,000.00
Traffic Control	\$ 150,000.00	1	LS	\$ 150,000.00
				Total= \$ 2,443,895.50
				Contingency (10%) = \$ 244,389.55
				Construction Total = \$ 2,688,285.05

Appendix D

Legal Description



**Legal Description
Fulton Homes Enclave**

Job No. 19-0254

March 2, 2020

A portion of East Half of Section 21, Township 2 North, Range 2 West, of the Gila and Salt River Meridian, Maricopa County, Arizona, and more particularly described as follows:

BEGINNING at a 3" C.O.G. brass cap in a hand hole at the southeast corner of said Section 21, from which a 3" C.O.G. brass cap in a hand hole at the south quarter corner of said Section 21, bears North 89 degrees 20 minutes 44 seconds West (an assumed bearing) at a distance of 2,649.31 feet;

thence North 89 degrees 20 minutes 44 seconds West, along the south line of the Southeast Quarter of said Section 21, 2574.31 feet to a point on the east line of the west 75.00 feet of said East Half;

thence North 0 degrees 30 minutes 45 seconds East, along said east line, 2626.82 feet;

thence continuing along said east line, North 0 degrees 30 minutes 45 seconds East, 659.08 feet to a point on the north line of the South Half of the Southwest Quarter of the Northeast Quarter of said Section 21;

thence South 89 degrees 35 minutes 47 seconds East, along said north line, 1245.94 feet to the northeast corner of the South Half of the Southwest Quarter of the Northeast Quarter of said Section 21;

thence South 0 degrees 26 minutes 53 seconds West, along the east line of the South Half of the Southwest Quarter of the Northeast Quarter of said Section 21, 329.61 feet to the northwest corner of the South Half of the South Half of the Southeast Quarter of the Northeast Quarter of said Section 21;

thence South 89 degrees 35 minutes 36 seconds East, along the north line of the South Half of the South Half of the Southeast Quarter of the Northeast Quarter of said Section 21, 1321.31 feet to the northeast corner of the South Half of the South Half of the Southeast Quarter of the Northeast Quarter of said Section 21, said point being on the east line of the Northeast Quarter of said Section 21;

thence South 0 degrees 23 minutes 02 seconds West, along said east line, 329.68 feet to the east quarter corner of said Section 21;

thence South 0 degrees 23 minutes 00 seconds West, along the east line of the Southeast Quarter of said Section 21, 2637.80 feet to the POINT OF BEGINNING.



Containing an area of 8,025,650 square feet or 184.2436 acres, more or less.



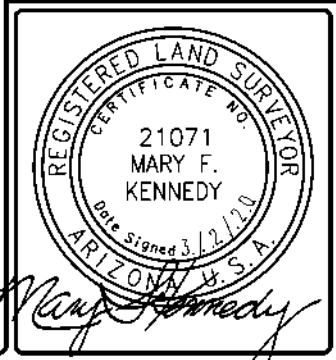
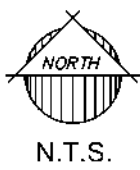
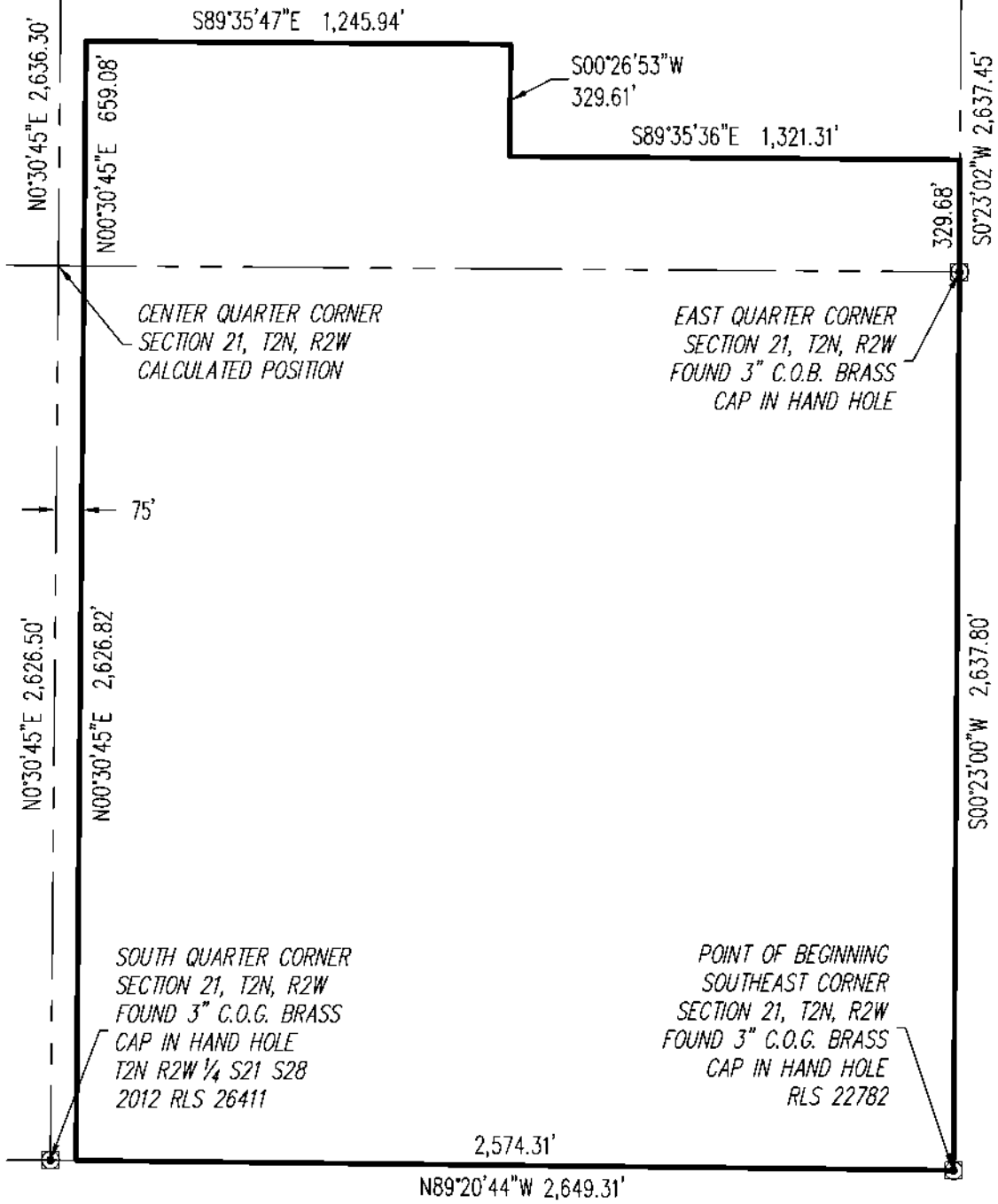

Mary Kennedy

19-0254	Fulton Homes Enclave		1130 N. Alma School Rd. Ste. 120 Mesa, AZ 85201 T:480.503.2250 F:480.503.2258 www.epsgroupinc.com
	EXHIBIT		

Appendix E

Request for Service Letter

Eyherabide Properties, LLC
&
Vincent and Rose-Ann Eyherabide Family Trust

18912 W. Indian School Road
Litchfield Park, Arizona 85340

January 6, 2020

Brad Finke, P.E.
Engineering Manager
EPCOR
2355 W. Pinnacle Peak Road, Suite 300
Phoenix, AZ 85027

RE: Request for Sewer Service – Eyherabide Property (NWC Indian School & Perryville)

Dear Mr. Finke:

This letter serves as a formal request for EPCOR Water Arizona Inc. to expand its sanitary sewer service area to include the Eyherabide property (APN's 502-29-006S, -006T, -016B, -016D, -016F, -016G, -016H, -024, -025, -042A and -042B) located at the NWC of Indian School Road and Perryville Road in Maricopa County, Arizona. No portion of this property is currently within EPCOR's sewer CC&N service area.

The requested expansion area covers approximately 181 acres located in the East Half of Section 21, Township 2 North, Range 2 West of the Gila and Salt River Meridian. The expansion area identified in this request is not currently served by any sewer utilities.

I appreciate your consideration of this request. Please feel free to contact Chris Webb with Rose Law Group pc at (480) 240-5648 or cwebb@roselawgroup.com if you need additional information.

Respectfully submitted,

Eyherabide Properties, LLC and the Vincent and Rose-Ann Eyherabide Family Trust



By: Rose-Ann Eyherabide

Exhibit 5
Aquifer Protection Permit



Jane Dee Hull
Governor

ARIZONA DEPARTMENT OF ENVIRONMENTAL QUALITY

1110 West Washington Street • Phoenix, Arizona 85007
(602) 771-2300 • www.adeq.state.az.us



Richard W. Tobin II
Acting Director

December 19, 2002

Troy Day, Director
Arizona-American Water Company
19820 N. 7th Street, Suite 201
Phoenix, AZ 85024

Re: Russell Ranch Wastewater Treatment Plant (WWTP)
Signed Aquifer Protection Permit (APP), File No. 105229

Dear Mr. Day:

Enclosed is a signed APP with Executive Summary for the above referenced facility. The permit conditions shall apply from December 18, 2002 which is the date of the Water Quality Division Director's signature, and shall be valid for the life of the facility. Thank you for your cooperation in protecting the water quality of the State of Arizona.

If you have any questions about this permit or need further assistance, please contact me at (800) 234-5677 ext. 771-4743 or at (602) 771-4743.

Sincerely,

Matthew Hodge, Project Manager
Wastewater, Recharge, & Reuse Unit
Water Permits Section, Water Quality Division

cc: Asif Majeed, Manager, Wastewater, Recharge, & Reuse Unit
Robert Casey, Manager, Enforcement Unit, Water Quality Compliance Section
Don Shroyer, Manager, Data Unit, Water Quality Compliance Section
Lynne Dekarske, Administrative Assistant, Water Permits Section
Lisa Farrington, Farrington Engineers, Inc, 4005 East Gable Circle Mesa, AZ 85206
Lisa Gregory, Recharge Coordinator, ADWR

MWR02:1104

Northern Regional Office
1515 East Cedar Avenue • Suite F • Flagstaff, AZ 86004
(928) 779-0313

Southern Regional Office
400 West Congress Street • Suite 433 • Tucson, AZ 85701
(520) 628-6733

EXECUTIVE SUMMARY
AQUIFER PROTECTION PERMIT NO. 105229

Facility Name:

Russell Ranch Water Reclamation Plant

Facility Location:

Russell Ranch Water Reclamation Plant is located in Glendale, Arizona in Maricopa County, over groundwater of the Phoenix Active Management Area, in Township 2 North, Range 2 West, and Section 15 of the Gila and Salt River Base Line and Meridian.

Regulatory Status:

This is a new facility and does not have any permits at present. The APP application for this facility was received on March 25, 2002.

Facility Description:

The Russell Ranch Water Reclamation Plant (WRP) will treat domestic effluent only derived from the Russell ranch sub-division. The WRP will be constructed in two phases consisting of 60,000 gallons per day (gpd) capacity and 138,000 gpd with a total build-out capacity of 198,000 gpd.

Wastewater processes include influent pumping, coarse screening, equalization, biological and biological nutrient removal (nitrification/de-nitrification) using an activated sludge system with clarification, and hypochlorite disinfection, followed by de-chlorination for removal of any chlorine residual.

Effluent will be recharged to the subsurface via two recharge basins adjacent to the WRP. Biosolids will be transported by the Arizona-American Water Company to its Sun City Wastewater Treatment Plant that currently provides solids handling.

Best Available Demonstrated Control Technology (BADCT):

The Wastewater Treatment Plant is designed to meet the treatment performance criteria for new facilities as specified in Arizona Administrative Code R18-9-B204.

Compliance with Aquifer Water Quality Standards (AWQS):

The facility performs discharge monitoring and is required to be in compliance with AWQS. As a result the AWQS are not expected to be violated at the at the point of compliance.

EXECUTIVE SUMMARY
AQUIFER PROTECTION PERMIT NO. 105229

Point of Compliance:

The Points of Compliance are established by the following locations:

P.O.C. Locations	Latitude	Longitude
Northeast corner of Basin 2	33° 30' 38" N	112° 26' 46" W
Approximately 60 ft east of the southeast corner of Basin 2	33° 30' 36" N	112° 26' 45" W

Storm/Surface Water Considerations:

The WWTP is outside the 100 year flood zone.

Zoning Requirements:

The permittee has provided the zoning information required pursuant to A.A.C. R18-9-A201(A)(2)(c).

Financial Capability:

The permittee has provided the financial capability information required pursuant to Rule R18-9-A203.

Technical Capability:

The permittee has provided the technical capability information required pursuant to Rule R18-9-A202.

**STATE OF ARIZONA
AQUIFER PROTECTION PERMIT NO. P- 105229
PLACE ID 16296, LTF 26497**

1.0 AUTHORIZATION

In compliance with the provisions of Arizona Revised Statutes (A.R.S.) Title 49, Chapter 2, Articles 1, 2 and 3, Arizona Administrative Code (A.A.C.) Title 18, Chapter 9, Articles 1 and 2, A.A.C. Title 18, Chapter 11, Article 4 and amendments thereto, and the conditions set forth in this permit, Arizona-American Water Company is hereby authorized to operate the Russell Ranch Water Reclamation Plant located in Glendale, Arizona in Maricopa County, over groundwater of the Phoenix Active Management Area, in Township 2 North, Range 2 West, and Section 15 of the Gila and Salt River Base Line and Meridian.

This permit becomes effective on the date of the Water Quality Division Director's signature and shall be valid for the life of the facility provided that the facility is constructed, operated, and maintained:

1. following all the conditions of this permit including the design and operational information documented or referenced below, and
2. such that Aquifer Water Quality Standards are not violated at the applicable point(s) of compliance set forth below.

1.1 PERMITTEE INFORMATION

Facility Name:	Russell Ranch Water Reclamation Plant	
Permittee:	Mailing Address:	Facility's Street Address:
Arizona-American Water Company	15626 North Del Webb Blvd. Sun City, AZ 85351	

Facility Contact: Mark Cardoza

Emergency Telephone Number: (623) 319-0226

Latitude: 33° 30' 37" N

Longitude: 112° 26' 54" W

Legal Description: Township 2 North, Range 2 West, and Section 15 of the Gila and Salt River Base Line and Meridian.

1.2 AUTHORIZING SIGNATURE



Karen L. Smith, Director
Water Quality Division

Arizona Department of Environmental Quality

Signed this 19th day of DECEMBER, 2002

2.0 SPECIFIC CONDITIONS [A.R.S. §§ 49-203(4), 49-241(A)]

2.1 Facility / Site Description [A.R.S. § 49-243(K)(8)]

The Russell Ranch Water Reclamation Plant (WRP) will treat domestic effluent only derived from the Russell ranch sub-division. The WRP will be constructed in two phases consisting of 60,000 gallons per day (gpd) capacity and 138,000 gpd with a total build-out capacity of 198,000 gpd.

Wastewater processes include influent pumping, coarse screening, equalization, and biological nutrient removal (nitrification/de-nitrification) using an activated sludge system with clarification, and hypochlorite disinfection, followed by de-chlorination for removal of any chlorine residual.

Effluent will be recharged to the subsurface via two recharge basins adjacent to the WRP. Biosolids will be transported by the Arizona-American Water Company to its Sun city Wastewater Treatment Plant that currently provides solids handling.

The site includes the following permitted discharging facilities:

Facility	Latitude	Longitude
Water Reclamation Plant	33° 30' 37" N	112° 26' 54" W

2.2 Best Available Demonstrated Control Technology [A.R.S. § 49-243(B) and A.A.C. R18-9-A202(A)(5)]

The Water Reclamation Plant is designed to meet the treatment performance criteria for new facilities as specified in Arizona Administrative Code R18-9-B204.

2.2.1 Engineering Design

This facility conforms with the specifications and design report, sealed and stamped February 28, 2002.

2.2.2 Site-specific Characteristics

Not Applicable.

2.2.3 Pre-Operational Requirements

Within 60 days of the signature date of this permit, the operator shall inspect the facility to verify that all components function as designed. The permittee shall provide written certification within 90 days of the signature date of this permit to ADEQ Water Quality Compliance, that inspection of all components was performed. The results of inspection should also be indicated.

2.2.4 Operational Requirements

1. The permittee shall maintain a copy of the new O & M manual at the WRP site at all times and shall be available upon request during inspections by ADEQ personnel.
2. The pollution control structures shall be inspected for the items listed in Section 4.0, TABLE III - FACILITY INSPECTION (OPERATIONAL MONITORING).
3. If any damage of the pollution control structures is identified during inspection, proper repair procedures shall be performed. All repair procedures and material(s) used shall be

documented on the Self-Monitoring Report Form submitted quarterly to the ADEQ Water Quality Compliance.

2.3 Discharge Limitations [A.R.S. §§ 49-201(14), 49-243 and A.A.C. R18-9-A205(B)]

The permittee is authorized to operate the Russell Ranch Water Reclamation Plant with a maximum average monthly flow of 198,000 gpd.

2.4 Point(s) of Compliance (P.O.C.) [A.R.S. § 49-244]

The Points of Compliance are established by the following locations:

P.O.C. Locations	Latitude	Longitude
Northeast corner of Basin 2	33° 30' 38" N	112° 26' 46" W
Approximately 60 ft east of the southeast corner of Basin 2	33° 30' 36" N	112° 26' 45" W

The Director may designate additional points of compliance if information on groundwater gradients or groundwater usage indicates the need.

2.5 Monitoring Requirements [A.R.S. § 49-243(K)(1), A.A.C. R18-9-A206(A)]

All monitoring required in this permit shall continue for the duration of the permit, regardless of the status of the facility. All sampling, preservation and holding times shall be in accordance with currently accepted standards of professional practice. Trip blanks, equipment blanks and duplicate samples shall also be obtained, and chain of custody procedures shall be followed, in accordance with currently accepted standards of professional practice. The permittee shall consult the most recent version of the ADEQ Quality Assurance Project Plan (QAPP) and EPA 40 CFR PART 136 for guidance in this regard. Copies of laboratory analyses and chain of custody forms shall be maintained at the permitted facility. Upon request these documents shall be made immediately available for review by ADEQ personnel.

2.5.1 Discharge Monitoring

The permittee shall monitor the wastewater according to Section 4.0, TABLE I. A representative sample of the wastewater shall be collected from the point of discharge from the chlorination basin.

It is suggested that flows of 25 homes or more are needed to allow the biologic process to work. The Maricopa County Environmental Health Services Department has agreed to allow Arizona-American to pump and haul the effluent until there are sufficient flows to the plant. The material hauled will be taken to the Sun City West (SCW) WWTP for treatment. Material from the SCW WWTP will be used at the Russell Ranch WWTP to "seed" the precess and allow for a quicker startup time for the biologic processes to begin.

2.5.2 Facility / Operational Monitoring

Operational monitoring inspections shall be conducted according to Section 4.0, TABLE III.

- a. If any damage of the pollution control structures is identified during inspection, proper repair procedures shall be performed. All repair procedures and materials used shall be documented on the Self-Monitoring Report Form (SMRF) submitted quarterly to the ADEQ Water

Quality Compliance. If none of the conditions occur, the report shall say "no event" for a particular reporting period. If the facility is not in operation, the permittee shall indicate that fact in the SMRF.

- b. The permittee shall submit data required in Section 4.0, TABLE III regardless of the operating status of the facility unless otherwise approved by the Department or allowed in this permit.

2.5.3 Groundwater Monitoring and Sampling Protocols

Routine groundwater monitoring is not required under the terms of this permit.

2.5.4 Surface Water Monitoring and Sampling Protocols

Not applicable. No surface monitoring is required.

2.5.5 Analytical Methodology

All samples collected for compliance monitoring shall be analyzed using Arizona state approved methods. If no state approved method exists, then any appropriate EPA approved method shall be used. Regardless of the method used, the detection limits must be sufficient to determine compliance with the regulatory limits of the parameters specified in this permit. Analyses shall be performed by a laboratory licensed by the Arizona Department of Health Services, Office of Laboratory Licensure and Certification. For results to be considered valid, all analytical work shall meet quality control standards specified in the approved methods. A list of Arizona state certified laboratories can be obtained at the address below:

Arizona Department of Health Services
Office of Laboratory Licensure and Certification
1740 W. Adams Street, Room 203 North
Phoenix, AZ 85007
Phone: (602) 364-0720

2.5.6 Installation and Maintenance of Monitoring Equipment

Monitoring equipment required by this permit shall be installed and maintained so that representative wastewater, groundwater, soil, water, or sludge samples can be collected. Should new groundwater wells be determined to be necessary, the construction details shall be submitted to the ADEQ Water Permits Section for approval.

2.6 Contingency Plan Requirements

[A.R.S. § 49-243(K)(3), (K)(7) and A.A.C. R18-9-A204 and R18-9-A205]

2.6.1 General Contingency Plan Considerations

At least one copy of the approved contingency and emergency response plan(s) submitted in the application shall be maintained at the location where day-to-day decisions regarding the operation of the facility are made. The permittee shall be aware of and follow the contingency and emergency plans.

Any alert level (AL) that is exceeded or any violation of an aquifer quality limit (AQL), discharge limit (DL), or other permit condition shall be reported to ADEQ following the reporting requirements in Section 2.7.3.

Some contingency actions involve verification sampling. Verification sampling shall consist of the first followup sample collected from a location that previously indicated a violation or that an

AL has been exceeded. Collection and analysis of the verification sample shall use the same protocols and test methods to analyze for the pollutant or pollutants that exceeded an AL or violated an AQL.

2.6.2 Exceeding of Alert Levels/Performance Levels

2.6.2.1 Exceeding of Alert Levels Set for Operational Conditions

1. If the operational PL set in Section 4.0, TABLE III has been exceeded the permittee shall:
 - a. Notify the ADEQ Water Quality Compliance Section within five (5) days of becoming aware of a violation of any permit condition.
 - b. Submit a written report within thirty (30) days after becoming aware of a violation of a permit condition. The report shall document all of the following:
 1. A description of the violation and its cause;
 2. the period of violation, including exact date(s) and time(s), if known, and the anticipated time period during which the violation is expected to continue;
 3. any action taken or planned to mitigate the effects or the violation, or the spill, or to eliminate or prevent recurrence of the violation;
 4. any monitoring activity or other information which indicates that any pollutants would be reasonably expected to cause a violation of an Aquifer Water Quality Standard; and
 5. any malfunction or failure of pollution control devices or other equipment or process.
2. The facility is no longer on alert status once the operational indicator no longer indicates that an PL is being exceeded. The permittee shall, however, complete all tasks necessary to return the facility to its pre-alert operating condition.

2.6.2.2 Exceeding of Alert Levels (AL) Set for Discharge Monitoring

1. If an AL set in Section 4.0, TABLE I has been exceeded, the permittee shall conduct verification sampling within 24 hours of becoming aware of the alert status.
2. If the verification sampling confirms that the AL has been exceeded, the permittee shall immediately investigate to determine the cause of the AL being exceeded. The investigation shall include the following:
 - a. Inspection, testing, and assessment of the current condition of all treatment or pollutant discharge control systems that may have contributed to the AL being exceeded.
 - b. Review of recent process logs, reports, and other operational control information to identify any unusual occurrences;
3. The permittee shall initiate actions identified in the approved contingency plan referenced in Part 5.0 and specific contingency measures identified in Part 2.6 to

resolve any problems identified by the investigation which may have led to an AL being exceeded. To implement any other corrective action the permittee shall obtain prior approval from ADEQ according to Section 2.6.6.

4. Within thirty (30) days after confirmation of an AL being exceeded, the permittee shall submit the laboratory results to the ADEQ Water Quality Compliance Section, Data Unit, along with a summary of the findings of the investigation, the cause of the AL being exceeded, and actions taken to resolve the problem.
5. Upon review of the submitted report, the Department may require additional monitoring, increased frequency of monitoring, amendments to permit conditions or other actions.

2.6.2.3 Exceeding of Alert Levels in Groundwater Monitoring

2.6.2.3.1 Alert Levels for Indicator Parameters

Not Applicable.

2.6.2.3.2 Alert Levels for Pollutants with Numeric Aquifer Water Quality Standards

Not Applicable

2.6.2.3.3 Alert Levels to Protect Down-gradient Users from Pollutants Without Numeric Aquifer Water Quality Standards

Not Applicable.

2.6.3 Discharge Limitations (DL) Violations

1. If a DL set in Section 4.0, TABLE I has been exceeded, the permittee shall conduct verification sampling within 24 hours of becoming aware of a DL being exceeded.
2. If verification sampling confirms that the DL has been violated, the permittee shall immediately investigate to determine the cause of the violation. The investigation shall include the following:
 - a. Inspection, testing, and assessment of the current condition of all treatment or pollutant discharge control systems that may have contributed to the violation;
 - b. Review of recent process logs, reports, and other operational control information to identify any unusual occurrences;
3. The permittee also shall submit a report according to Section 2.7.3, which includes a summary of the findings of the investigation, the cause of the violation, and actions taken to resolve the problem. The permittee shall consider and ADEQ may require corrective action that may include control of the source of discharge, cleanup of affected soil, surface water or groundwater, and mitigation of the impact of pollutants on existing uses of the aquifer. Corrective actions shall either be specifically identified in this permit, included in an ADEQ approved contingency plan, or separately approved according to Section 2.6.6.
4. Upon review of the submitted report, the Department may require additional monitoring, increased frequency of monitoring, amendments to permit conditions or other actions.

2.6.4 Aquifer Quality Limit (AQL) Violation

Not Applicable. Groundwater monitoring is not required at the current time.

2.6.5 Emergency Response and Contingency Requirements for Spills and Unauthorized Discharges**2.6.5.1 Duty to Respond**

The permittee shall act immediately to correct any condition that could pose an endangerment to public health or the environment.

2.6.5.2 Spills of Hazardous Substances or Toxic Pollutants

In the event of any accidental spill or unauthorized discharge (A.R.S. § 49-201(12)) of suspected hazardous substances (A.R.S. § 49-201(18)) or toxic pollutants (A.R.S. § 49-243(I)) on the facility site, the permittee shall promptly isolate the area and attempt to identify the spilled material. The permittee shall record information, including name, nature of exposure and follow-up medical treatment, if necessary, on persons who may have been exposed during the incident. Spilled materials, absorbents, and contaminated media generated during emergency response shall be removed and disposed of according to applicable federal, state and local regulations. The emergency response coordinator shall notify the ADEQ Emergency Response Unit at (602) 771-2300 immediately upon discovering a release of a hazardous substance in excess of a reportable quantity in accordance with 40 CFR Part 302, *et seq.*

2.6.5.3 Discharge of Non-hazardous Materials

In the event of any unauthorized discharge of non-hazardous materials from the facility, the permittee shall promptly attempt to cease the discharge and isolate the discharged material. Discharged material shall be removed and the site cleaned up as soon as possible. The permittee shall notify the ADEQ Water Quality Compliance Section, Enforcement Unit at (602) 771-2300 within 24-hours upon discovering the discharge of non-hazardous material which: a) has the potential to cause an AQL to be exceeded; or b) could pose an endangerment to public health or the environment.

2.6.5.4 Reporting Requirements

The permittee shall submit a written report for any unauthorized discharges described in Sections 2.6.5.2 and 2.6.5.3 to ADEQ Water Quality Compliance Section, Enforcement Unit, Mail Code: 5415B-1, 1110 West Washington Street, Phoenix, AZ 85007 within thirty days of the discharge or as required by subsequent ADEQ action. The report shall summarize the event, including any human exposure, and facility response activities and include all information specified in Section 2.7.3. If a notice is issued by ADEQ subsequent to the discharge notification, any additional information requested in the notice shall also be submitted within the time frame specified in that notice. Upon review of the submitted report, ADEQ may require additional monitoring or corrective actions.

2.6.6 Corrective Actions

Specific contingency measures identified in Part 2.6 have already been approved by ADEQ and do not require written approval to implement.

With the exception of emergency response actions taken under Section 2.6.5, the permittee shall

obtain written approval from the Water Permits Section prior to implementing a corrective action to accomplish any of the following goals in response to exceeding an AL or violation of an AQL, DL, or other permit condition:

1. Control of the source of an unauthorized discharge;
2. Soil cleanup;
3. Cleanup of affected surface waters;
4. Cleanup of affected parts of the aquifer;
5. Mitigation to limit the impact of pollutants on existing uses of the aquifer.

Within 30 days of completion of any corrective action, the operator shall submit to the ADEQ Water Quality Compliance Section, a written report describing the causes, impacts, and actions taken to resolve the problem.

2.7 Reporting and Recordkeeping Requirements

[A.R.S. § 49-243(K)(2) and A.A.C. R18-9-A206(B) and R18-9-A207]

2.7.1 Self Monitoring Report Forms (SMRF)

1. The permittee shall complete the SMRFs provided by ADEQ, and submit them to the Water Quality Compliance Section, Data Unit.
2. The permittee shall complete the SMRF to the extent that the information reported may be entered on the form. If no information is required during a quarter, the permittee shall enter "not required" on the SMRF and submit the report to ADEQ. The permittee shall use the format devised by ADEQ.
3. The tables contained in Sections 4.0 list the parameters to be monitored and the frequency for reporting results for groundwater compliance monitoring. Monitoring methods shall be recorded on the SMRFs.
4. In addition to the SMRF, the information contained in Section 6.9.3 shall be included for exceeding an AL or violation of an AQL, DL, or any other permit condition being reported in the current reporting period.

2.7.2 Operation Inspection/Log Book Recordkeeping

A signed copy of this permit shall be maintained at all times at the location where day-to-day decisions regarding the operation of the facility are made. A log book of the inspections and measurements required by this permit shall be maintained at the location where day-to-day decisions are made regarding the operation of the facility. The log book shall be retained for ten years from the date of each inspection, and upon request, the permit and the log book shall be made immediately available for review by ADEQ personnel. The information in the log book shall include, but not be limited to, the following information as applicable:

1. name of inspector;
2. date and shift inspection was conducted;
3. condition of applicable facility components;

4. any damage or malfunction, and the date and time any repairs were performed;
5. documentation of sampling data and time;
6. names of samples;
7. static water level in monitor well prior to sampling;
8. sampling method;
9. purging volume;
10. indicator parameters including field conductance ($\mu\text{mhos/cm}$), field temperature ($^{\circ}\text{C}$), and field pH (standard units);
11. date of analysis;
12. preservation and transportation procedures;
13. the name of the analytical facility, and;
14. any other information as specified by this permit to be entered in the log book.

2.7.3 Permit Violation and Alert Level Status Reporting

1. The permittee shall notify the Water Quality Compliance Section, Enforcement Unit in writing within five days (except as provided in Section 2.6.5) of becoming aware of a violation of any permit condition, discharge limitation or of an Alert Level being exceeded.
2. The permittee shall submit a written report to the Water Quality Compliance Section, Enforcement Unit within 30 days of becoming aware of the violation of any permit condition or discharge limitation. The report shall document all of the following:
 - a. Identification and description of the permit condition for which there has been a violation and a description of its cause.
 - b. The period of violation including exact date(s) and time(s), if known, and the anticipated time period during which the violation is expected to continue.
 - c. Any corrective action taken or planned to mitigate the effects of the violation, or to eliminate or prevent a recurrence of the violation.
 - d. Any monitoring activity or other information which indicates that any pollutants would be reasonably expected to cause a violation of an Aquifer Water Quality Standard.
 - e. Proposed changes to the monitoring which include changes in constituents or increased frequency of monitoring.
 - f. Description of any malfunction or failure of pollution control devices or other equipment or processes.

2.7.4 Operational, Other or Miscellaneous Reporting

The permittee shall complete the Self-Monitoring Report Form provided by the Department to reflect facility inspection requirements designated in Section 4.0, TABLE III and submit to the

ADEQ, Water Quality Compliance quarterly along with other reports required by this permit. Facility inspection reports shall be submitted no less frequently than quarterly, regardless of operational status.

The permittee shall submit the results of water quality testing for total nitrogen, fecal coliform, turbidity and flow volumes to any of the following in accordance with A.A.C. R18-9-703(C)(2)(c):

1. Any reclaimed water agent who has contracted for delivery of reclaimed water from the permittee;
2. Any end user who has not waived interest in receiving this information.

2.7.5 Reporting Location

All SMRFs shall be submitted to:

Arizona Department of Environmental Quality
Water Quality Compliance Section, Data Unit
Mail Code: 5415B-1
1110 W. Washington Street
Phoenix, AZ 85007
Phone (602) 771-4681

All documents required by this permit to be submitted to the Water Quality Compliance Section shall be directed to:

Water Quality Compliance Section, Enforcement Unit
Mail Code: 5415B-1
1110 W. Washington Street
Phoenix, AZ 85007
Phone (602) 771-4614

All documents required by this permit to be submitted to the Water Permits Section shall be directed to:

Arizona Department of Environmental Quality
Water Permits Section
Mail Code: 5415B-3
1110 W. Washington Street
Phoenix, AZ 85007
Phone (602) 771-4428

2.7.6 Reporting Deadline

The following table lists the quarterly report due dates:

Monitoring conducted during quarter:	Quarterly Report due by:
January-March	April 30
April-June	July 30
July-September	October 30
October-December	January 30

2.7.7 Changes to Facility Information in Section 1.0

The Water Permits Section and Water Quality Compliance Section shall be notified within 10 days of any change of facility information including Facility Name, Permittee Name, Mailing or Street Address, Facility Contact Person or Emergency Telephone Number.

2.8 Temporary Cessation [A.R.S. § 49-243(K)(8) and A.A.C. R18-9-A209(A)]

The permittee shall give written notice to the Water Quality Compliance Section upon ceasing operation of the facility for a period of 60 days or greater. The permittee shall take the following measures upon temporary cessation:

1. If applicable, direct the wastewater flows from the facility to another State approved wastewater treatment facility.
2. Correct the problem that caused the temporary cessation of the facility.
3. Notify ADEQ with a monthly facility Status Report describing the activities conducted on the WWTP to correct the problem

At the time of notification the permittee shall submit for ADEQ approval a plan for maintenance of discharge control systems and for monitoring during the period of temporary cessation. Immediately following ADEQ's approval, the permittee shall implement the approved plan. If necessary, ADEQ shall amend permit conditions to incorporate conditions to address temporary cessation. If the facility will cease operation, the permittee shall submit closure notification, as set forth in Section 2.9 below.

2.9 Closure [A.R.S. §§ 49-243(K)(6), 49-252 and A.A.C. R18-9-A209(B)]

The permittee shall give written notice of closure to the Water Quality Compliance Section before closing, or before ceasing use of a facility addressed under this permit if the cessation is projected to last more than three years.

Within 90 days following notification of closure, the permittee shall submit for approval to the Water Permits Section, a detailed Closure Plan which meets the requirements of A.R.S. § 49-252 and A.A.C. R18-9-A209(B)(1)(a).

If the closure plan achieves clean closure immediately, ADEQ shall issue a letter of approval to the permittee. If the closure plan contains a schedule for bringing the facility to a clean closure configuration at a future date, ADEQ may incorporate any part of the schedule as an amendment to this permit.

Upon completion of closure activities, the permittee shall give written notice to the Water Permits Section indicating that the approved Closure Plan has been implemented fully. If clean closure has been achieved, ADEQ shall issue a letter of approval to the permittee at that time. If any of the following conditions apply, the permittee shall follow the terms of Post Closure stated in this permit:

1. Clean closure cannot be achieved at the time of closure notification or within one year thereafter under a diligent schedule of closure actions;
2. Further action is necessary to keep the facility in compliance with aquifer water quality standards at the applicable point of compliance;
3. Continued action is required to verify that the closure design has eliminated discharge to the extent intended;
4. Remedial or mitigative measures are necessary to achieve compliance with Title 49, Ch. 2;
5. Further action is necessary to meet property use restrictions.

2.9.1 Closure Plan

A specific closure plan is not required at the time of permit issuance.

2.9.2 Closure Completion

Not required at the time of permit issuance.

2.10 Post-Closure [A.R.S. §§ 49-243(K)(6), 49-252 and A.A.C. R18-9 A209(C)]

Post-closure requirements shall be established based on a review of facility closure actions and will be subject to review and approval by the Water Permits Section.

In the event clean closure cannot be achieved pursuant to A.R.S. § 49-252, the permittee shall submit for approval to the Water Permits Section a Post-Closure Plan that addresses post-closure maintenance and monitoring actions at the facility. The Post-Closure Plan shall meet all requirements of A.R.S. §§ 49-201(29) and 49-252 and A.A.C. R18-9-A209(C). Upon approval of the Post-Closure Plan, this permit shall be amended or a new permit shall be issued to incorporate all post-closure controls and monitoring activities of the Post-Closure Plan.

2.10.1 Post-Closure Plan

A specific post-closure plan is not required at the time of permit issuance.

2.10.2 Post-Closure Completion

Not required at the time of permit issuance.

3.0 COMPLIANCE SCHEDULE [A.R.S. § 49-243(K)(5) and A.A.C. R18-9-A208]

None required at this time.

4.0 TABLES OF MONITORING REQUIREMENTS

**TABLE I
DISCHARGE MONITORING**

Sampling Point Number	Sampling Point Identification	Latitude	Longitude		
1	Point of discharge from chlorination basin.	33° 30' 37" N	112° 26' 52" W		
Parameter	AL ¹	DL ²	Units	Sampling Frequency	Reporting Frequency
Flow: Daily	Reserved	Reserved ³	N/A	Daily ⁴	Quarterly
Flow: Average Monthly	0.188	0.198	MGD ⁵	Monthly ⁶	Quarterly
Fecal Coliform (single sample maximum)	Reserved	800	CFU ⁷	Monthly	Quarterly
Fecal Coliform (4 of 7 samples)	Reserved	200	CFU	Monthly (Calculated)	Quarterly
Total Nitrogen ⁸	Reserved	10.0 ⁹	mg/l	Monthly	Quarterly
Nitrate as N	8.0	10.0	mg/l	Monthly	Quarterly
Nitrite as N	0.8	1.0	mg/l	Monthly	Quarterly
Total Kjeldahl Nitrogen (TKN)	Reserved	Reserved	mg/l	Monthly	Quarterly

¹ AL = Alert Level.

² DL = Discharge Limit.

³ Reserved = No limits are specified.

⁴ Flow shall be measured using a continuous recording flow meter.

⁵ MGD = Million Gallons per Day

⁶ Monthly = Calculated value = Average of daily flows in a month.

⁷ CFU = Colony Forming Units per 100 ml

⁸ Total Nitrogen is equal to nitrate as N plus nitrite as N plus TKN.

⁹ A 5-Month Geometric Mean of the results of the 5 most recent samples.

4.0 TABLES OF MONITORING REQUIREMENTS

TABLE I
DISCHARGE MONITORING (Continued)

Parameter	AL	DL	Units	Sampling Frequency	Reporting Frequency
Metals (Total):					
Antimony	0.0048	0.006	mg/l	Quarterly	Quarterly
Arsenic	0.04	0.05	mg/l	Quarterly	Quarterly
Barium	1.60	2.00	mg/l	Quarterly	Quarterly
Beryllium	0.0032	0.004	mg/l	Quarterly	Quarterly
Cadmium	0.004	0.005	mg/l	Quarterly	Quarterly
Chromium	0.08	0.1	mg/l	Quarterly	Quarterly
Cyanide (As free cyanide)	0.16	0.2	mg/l	Quarterly	Quarterly
Fluoride	3.2	4.0	mg/l	Quarterly	Quarterly
Lead	0.04	0.05	mg/l	Quarterly	Quarterly
Mercury	0.0016	0.002	mg/l	Quarterly	Quarterly
Nickel	0.08	0.1	mg/l	Quarterly	Quarterly
Selenium	0.04	0.05	mg/l	Quarterly	Quarterly
Thallium	0.0016	0.002	mg/l	Quarterly	Quarterly

4.0 TABLES OF MONITORING REQUIREMENTS

TABLE I
DISCHARGE MONITORING (Continued)

Parameter	AL	DL	Units	Sampling Frequency	Reporting Frequency
Volatile Organic Compounds (VOCs):					
Benzene	4.0	5.0	ug/l	Annually	Annually
Carbon tetrachloride	4.0	5.0	ug/l	Annually	Annually
o-Dichlorobenzene	480.0	600.0	ug/l	Annually	Annually
para-Dichlorobenzene	60.0	75.0	ug/l	Annually	Annually
1,2-Dichloroethane	4.0	5.0	ug/l	Annually	Annually
1,1-Dichloroethylene	5.6	7.0	ug/l	Annually	Annually
cis-1,2-Dichloroethylene	56.0	70.0	ug/l	Annually	Annually
trans-1,2-Dichloroethylene	80.0	100.0	ug/l	Annually	Annually
Dichloromethane	4.0	5.0	ug/l	Annually	Annually
1,2-Dichloropropane	4.0	5.0	ug/l	Annually	Annually
Ethylbenzene	560.0	700.0	ug/l	Annually	Annually
Monochlorobenzene	80.0	100.0	ug/l	Annually	Annually
Styrene	80.0	100.0	ug/l	Annually	Annually
Tetrachloroethylene	4.0	5.0	ug/l	Annually	Annually
Toluene	800.0	1000.0	ug/l	Annually	Annually
Trihalomethanes (total) ¹⁰	80.0	100.0	ug/l	Annually	Annually
1,1,1-Trichloroethane	160.0	200.0	ug/l	Annually	Annually
1,2,4 - Trichlorobenzene	56.0	70.0	ug/l	Annually	Annually
1,1,2 - Trichloroethane	4.0	5.0	ug/l	Annually	Annually
Trichloroethylene	4.0	5.0	ug/l	Annually	Annually
Vinyl Chloride	1.6	2.0	ug/l	Annually	Annually
Xylenes (Total)	8000.0	10,000.0	ug/l	Annually	Annually

¹⁰ Total Trihalomethanes comprises of Bromoform, Bromodichloromethane, Chloroform, and Dibromochloromethane.

4.0 TABLES OF MONITORING REQUIREMENTS

**TABLE II
GROUNDWATER MONITORING
NOT REQUIRED**

**TABLE III
FACILITY INSPECTION (Operational Monitoring)**

Pollution Control Structures/Parameter	Performance Levels	Inspection Frequency
Pump Integrity	Good Working Condition	Weekly
Treatment Plant Components	Good Working Condition	Weekly
Berm Integrity	No Visible Erosion	Monthly

5.0 REFERENCES AND PERTINENT INFORMATION

The terms and conditions set forth in this permit have been developed based upon the information contained in the following, which are on file with the Department:

- 1 APP Application dated March 25, 2002.
- 2 Public Notice, dated October 17, 2002.
- 3 Public Hearing, dated N/A.
- 4 Responsiveness Summary, dated N/A.

6.0 GENERAL CONDITIONS AND RESPONSIBILITIES

6.1 Annual Registration Fees

The permittee shall pay an Annual Registration Fee to ADEQ. The Annual Registration Fee is based upon the amount of daily influent or discharge of pollutants in gallons per day as established by A.R.S. § 49-242(D). This fee is payable to ADEQ by January 31, each year.

6.2 Duty to Comply [A.R.S. §§ 49-221 through 263]

The permittee shall comply with all conditions of this permit and all applicable provisions of Title 49, Chapter 2, Articles 1, 2 and 3 of the Arizona Revised Statutes, Title 18, Chapter 9, Articles 1 through 4, and Title 18, Chapter 11, Article 4 of the Arizona Administrative Code. Any permit non-compliance constitutes a violation and is grounds for an enforcement action pursuant to Title 49, Chapter 2, Article 4 or permit modification, suspension, or revocation.

6.3 Duty to Provide Information [A.R.S. §§ 49-243(K)(2) and 49-243(K)(8)]

The permittee shall furnish to the Director, or an authorized representative, within a time specified, any information which the Director may request to determine whether cause exists for amending or terminating this permit, or to determine compliance with this permit. The permittee shall also furnish to the Director, upon request, copies of records required to be kept by this permit.

6.4 Severability [A.R.S. § 49-243(K)(8)]

The provisions of this permit are severable, and if any provision of this permit, or the application of any provision of this permit to any circumstance, is held invalid, the application of such provision to other circumstances, and the remainder of this permit, shall not be affected thereby.

6.5 Proper Operation and Maintenance [A.R.S. § 49-243(K)(8)]

The permittee shall, at all times, properly operate and maintain all facilities, treatment processes, and discharge control systems which are installed or used by the permittee to achieve compliance with the terms and conditions of this permit.

6.6 Compliance with Aquifer Water Quality Standards [A.R.S. §§ 49-243(B)(2) and 49-243(B)(3)]

The permittee shall not cause or contribute to a violation of an aquifer water quality standard at the applicable point of compliance for the facility. Where, at the time of issuance of the permit, an aquifer already exceeds an aquifer water quality standard for a pollutant, the permittee shall not discharge that pollutant so as to further degrade, at the applicable point of compliance for the facility, the water quality of any aquifer for that pollutant.

6.7 Technical and Financial Capability [A.R.S. §§ 49-243(K)(8) and 49-243(N) and A.A.C. R18-9-A202(B) and R18-9-A203(E) and (F)]

The permittee shall have and maintain the technical and financial capability necessary to fully carry out the terms and conditions of this permit. Any bond, insurance policy, trust fund, or other financial assurance mechanism provided as a demonstration of financial capability in the permit application, pursuant to A.A.C. R18-9-A203(D), shall be in effect prior to any discharge authorized by this permit and shall remain in effect for the duration of the permit.

6.8 Reporting of Bankruptcy or Environmental Enforcement [A.A.C. R18-9-A207(C)]

The permittee shall notify the Director within five days after the occurrence of any one of the following:

1. The filing of bankruptcy by the permittee.
2. The entry of any order or judgment not issued by the Director against the permittee for the enforcement of any environmental protection statute or rule.

6.9 Monitoring and Records [A.R.S. § 49-243(K)(8) and A.A.C. R18-9-A206]

The permittee shall conduct any monitoring activity necessary to assure compliance with this permit, with the applicable water quality standards established pursuant to A.R.S. §§ 49-221 and 49-223 and §§ 49-241 through 49-252.

1. Samples and measurements taken for the purpose of monitoring shall be representative of the monitored activity.
2. The permittee shall retain records of all monitoring information, including copies of all reports required by this permit and records of all data used to complete the application for this permit, for a period of 10 years from the date of the sample, measurement report, or application. This period may be extended by request of the Director at any time.
3. At a minimum, records of monitoring information shall include:
 - a. The date, time, and exact place of sampling or measurements
 - b. The individual(s) who performed the sampling or measurements
 - c. The date(s) analyses were performed
 - d. The individual(s) who performed the analyses
 - e. The analytical techniques or methods used
 - f. The results of such analyses
 - g. The chain of custody records, and
 - h. Any field notes relating to the information described in (a) - (g) above.

6.10 Other information [A.R.S. § 49-243(K)(8)]

Where the permittee becomes aware that it failed to submit any relevant facts in a permit application, or submitted incorrect information in a permit application or in any report to the Director, the permittee shall promptly submit the correct facts or information.

6.11 Inspection and Entry [A.R.S. §§ 49-203(B) and 49-243(K)(8)]

The permittee shall allow the Director, or an authorized representative, upon the presentation of credentials and other documents as may be required by law, to enter and inspect the facility as reasonably necessary to ensure compliance with Title 49, Chapter 2, Article 3 of the Arizona Revised Statutes, and Title 18, Chapter 9, Articles 1 through 4 of the Arizona Administrative Code and the terms and conditions of this permit. In so doing, the Department representative may:

1. Enter upon the operator's premises where a regulated facility or activity is located or conducted, or locations where records must be kept under the conditions of this permit.
2. Have access to and copy, at reasonable times, any records required to be kept under the conditions

of this permit.

3. Inspect at reasonable times any facilities, equipment (including monitoring and control equipment), practices, or operations regulated or required under this permit.
4. Sample or monitor at reasonable times, for the purposes of assuring permit compliance, any substances or parameters at any location.
5. Take photographs or video tape.
6. Take other actions reasonably necessary to determine compliance with Aquifer Protection Permit statutes or rules or the terms and conditions of this permit.

6.12 Duty to Modify [A.R.S. § 49-243(K)(8)]

The permittee shall apply for and receive a written amendment before deviating from any of the designs or operational practices authorized by this permit.

**6.13 Permit Action: Amendment, Transfer, Suspension & Revocation
[A.R.S. §§ 49-201, 49-241 through 251, A.A.C. R18-9-A211, R18-9-A212 and R18-9-A213]**

This permit may be amended, transferred, renewed, or revoked for cause, under the rules of the Department. The filing of a request by the permittee for a permit action does not stay or suspend the effectiveness of any existing permit condition. The Director shall issue a public notice of all proposed permit actions pursuant to A.A.C. R18-9-A211, R18-9-A212 and R18-9-A213.

6.13.1 Permit Reopen

The Director may reopen this permit and amend it pursuant to A.A.C. R18-9-A211.

6.13.2 Permit Transfer

This permit may not be transferred to any other person except after notice to and approval of the transfer by the Department. No transfer will be approved until the applicant complies with all transfer requirements as specified in A.A.C. R18-9-A212(B) and (C).

The permittee shall notify the Water Permits Section in writing within 15 days after any change in the owner or operator of the facility. The notification shall state the permit number, the name of the facility, the date of property transfer, and the name, address, and phone number where the new owner or operator can be reached. The operator shall advise the new owner or operators of the terms of this permit and the need for permit transfer in accordance with the rules.

Exhibit 6
Estimated Total Construction Costs

Engineer's Estimate of Probable Cost

Project Name: Fulton Homes Enclave
Project Phase: Construction Documents
EPS Project No.: 19-0254
Date: 6/24/2020



Description	Unit Price	Quantity	Unit	Cost
Sewer Infrastructure Improvements				
6" PVC Force Main (Class 300)	\$ 35.00	9,179	LF	\$ 321,265.00
8" PVC (SDR-35) Sewer Pipe	\$ 39.00	26,312	LF	\$ 1,026,168.00
10" PVC (SDR-35) Sewer Pipe	\$ 44.00	70	LF	\$ 3,080.00
4' Sewer Manhole w/30" cover; MAG 420-1,423-2	\$ 4,300.00	89	EA	\$ 382,700.00
Sewer Testing	\$ 5.00	35,561	LF	\$ 177,805.00
Lift Station	\$ 330,477.50	1	LS	\$ 330,477.50
Sawcut Pavement, Remove, and Replace pavement in kind	\$ 25.00	796	SY	\$ 19,900.00
Combination Air/Vacuum Sewage Release Valve	\$ 5,000.00	1	EA	\$ 5,000.00
Connection to Ex. Manhole	\$ 4,500.00	1	EA	\$ 4,500.00
Sewer Vertical Realignment	\$ 1,500.00	2	EA	\$ 3,000.00
Jack & Jack w/ Casing	\$ 1,000.00	20	LF	\$ 20,000.00
Traffic Control	\$ 150,000.00	1	LS	\$ 150,000.00
				Total= \$ 2,443,895.50
				Contingency (10%) = \$ 244,389.55
				Construction Total = \$ 2,688,285.05

Exhibit 7
Financial Statement

EPCOR WATER ARIZONA INC.
BALANCE SHEET
DECEMBER 31, 2019
(in \$000)

ASSETS	December 31, 2019
Utility plant	\$ 1,300,914
Less: accumulated depreciation	(471,856)
Construction work in process	63,937
Net utility plant	<u>892,995</u>
Current assets	
Cash and cash equivalents	79
Trade and other receivables	6,444
Unbilled revenue	10,661
Prepaid expenses	1,848
Inventories	1,881
Total current assets	<u>20,914</u>
Non-current assets	
Regulatory assets	29,887
Inter-company receivable	72,714
Intangible assets	1,584
Total non-current assets	<u>104,185</u>
TOTAL ASSETS	<u><u>\$ 1,018,094</u></u>
CAPITALIZATION AND LIABILITIES	
Common stockholder's equity	\$ 261,773
Long term debt, less current maturities	256,150
Total capitalization	<u>517,922</u>
Current liabilities	
Trade and other payables, net	57,835
Loans and borrowings	598
Advances for Construction	2,040
Other current liabilities	1,061
Total current liabilities	<u>61,534</u>
Non-current liabilities	
Advances for Construction	143,313
Contributions in aid of construction, net	237,633
Deferred tax liabilities, net	18,914
Other liabilities	38,778
Total non-current liabilities	<u>438,637</u>
TOTAL CAPITALIZATION AND LIABILITIES	<u><u>\$ 1,018,094</u></u>

EPCOR WATER ARIZONA INC.
STATEMENTS OF INCOME
YEAR ENDED DECEMBER 31, 2019

(in thousands)

	<u>2019</u>
Revenue	
Water sales	143,362
Other income	4,872
Total operating revenues	148,234
Operating expenses	
Other raw materials and operating charges	19,594
Staff costs and employee benefits expenses	20,843
Other operating expenses	8,000
Depreciation and amortization	35,291
Other administrative expenses	14,809
Property Taxes	5,415
Total operating expenses, net	<u>103,952</u>
Operating income	<u>44,282</u>
Other income (expenses)	
Financing expenses	(10,166)
Income taxes	(5,082)
Total other income (expenses)	<u>(15,248)</u>
Net income	<u>\$ 29,034</u>

EPCOR Water Arizona Inc.

5 Year Utility Plant Projections

Total Company with added Agua Fria CC&N Extension

(In \$000's)

	BALANCE AT END OF 2019	Year 1 Projected Changes	Year 1 Projected Company Total	Year 2 Projected Changes	Year 2 Projected Company Total	Year 3 Projected Changes	Year 3 Projected Company Total	Year 4 Projected Changes	Year 4 Projected Company Total	Year 5 Projected Changes	Year 5 Projected Company Total
Utility plant	\$ 1,300,914	\$ 2,019	\$ 1,302,933	\$ 669	\$ 1,303,602	\$ -	\$ 1,303,602	\$ -	\$ 1,303,602	\$ -	\$ 1,303,602
Less: accumulated depreciation	\$ (471,856)	(28)	(471,884)	(65)	(471,949)	(74)	(472,023)	(74)	(472,098)	(74)	(472,172)
Construction work in process	\$ 63,937		63,937		63,937		63,937		63,937		63,937
Net utility plant	892,995	1,991	894,986	604	895,590	(74)	895,516	(74)	895,441	(74)	895,367

Exhibit 8
Authorized Tariffs

TABLE OF CONTENTS

General Wastewater Service	Sheet No. 1
General Wastewater Service (cont.)	Sheet No. 1a
General Wastewater Service (cont.)	Sheet No. 1b
General Wastewater Service (cont.)	Sheet No. 1c
General Wastewater Service (cont.)	Sheet No. 1d
General Wastewater Service (cont.)	Sheet No. 1e
General Wastewater Service (cont.)	Sheet No. 1f
General Wastewater Service (cont.)	Sheet No. 1g
General Wastewater Service (cont.)	Sheet No. 1h
Industrial Discharge Service	Sheet No. 2
Off-Site Facilities Hook-Up Fees	Sheet No. 3
Off-Site Facilities Hook-Up Fees (cont.)	Sheet No. 3a
Off-Site Facilities Hook-Up Fees (cont.)	Sheet No. 3b
Service Charges	Sheet No. 4
Effluent	Sheet No. 5
Low Income Program Tariff	Sheet No. 6
Deployed Service Member Program Tariff	Sheet No. 7
Tax Cuts and Jobs Act ("TCJA") Tariff Rider – On-Going Monthly Credit	Sheet No. 8
Tax Cuts and Jobs Act ("TCJA") Tariff Rider – On-Going Monthly Credit (cont.)	Sheet No. 8a
Tax Cuts and Jobs Act ("TCJA") Tariff Rider – One-Time Credit	Sheet No. 8b
Tax Cuts and Jobs Act ("TCJA") Tariff Rider – One-Time Credit (cont.)	Sheet No. 8c

APPROVED FOR FILING

DECISION #: 76772

EPCOR Water Arizona, Inc.
(Name of Company)Arizona Wastewater District
(Name of Service Area)

General Wastewater Service

Availability

Available to all customers in the served area but the Company reserves the right to restrict service to those customers using water service of Company or affiliated company.

Note: Charges are applied up to the usage indicated in the schedules. Amounts in excess of the gallons included have no charges.

Schedule of Charges

Step 1 Rates: Effective July 1, 2017 through June 30, 2018

Current Rate Schedules		Monthly Minimum Charge	Commodity Rates (per 1,000 gallons)	Maximum Gallons at Commodity Rates
Agua Fria Wastewater				
C1MS1	Residential	\$ 62.44	-N/A-	-N/A-
C2MS1	Commercial 5/8 Inch	\$ 42.27	\$ 4.8594	5,000
C2MS2	Commercial 3/4 Inch	\$ 56.12	\$ 4.8594	5,000
C2MS3	Commercial 1 Inch	\$ 91.97	\$ 4.8594	12,500
C2MS4	Commercial LG 1 1/2 Inch	\$ 162.01	\$ 4.8594	25,000
C2MS5	Commercial LG 2 Inch	\$ 183.94	\$ 4.8594	40,000
Anthem Wastewater				
E1MS1	Residential	\$ 59.15	-N/A-	-N/A-
E2MS1	Commercial 5/8 Inch	\$ 30.94	\$ 3.5359	5,000
E2MS2	Commercial 3/4 Inch	\$ 39.13	\$ 3.5359	5,000
E2MS3	Commercial 1 Inch	\$ 69.29	\$ 3.5359	12,500
E2MS4	Commercial 1 1/2 Inch	\$ 83.89	\$ 3.5359	25,000
E2MS5	Commercial 2 Inch	\$ 105.82	\$ 3.5359	40,000
E2MSA	Commercial LG 1 Inch	\$ 102.06	\$ 3.5359	12,500
E2MSB	Commercial LG 1 1/2 Inch	\$ 116.67	\$ 3.5359	25,000
E2MSC	Commercial LG 2 Inch	\$ 138.60	\$ 3.5359	40,000
E5M2	Wholesale (Phoenix) OWU	-N/A-	\$ 3.9232	All Usage
Mohave Wastewater				
P1MS1	Residential	\$ 57.28	-N/A-	-N/A-
P2MS1	Commercial	\$ 124.11	-N/A-	-N/A-
P2MS4	Commercial LG	\$ 111.98	\$ 2.6945	All Usage
P4MS1	OPA	\$ 63.98	-N/A-	-N/A-

(continued on Sheet 1a)

ISSUED: June 30, 2017 EFFECTIVE: July 1, 2017
 Month Day Year Month Day Year
 ISSUED BY: Sheryl Hubbard, Director, Regulatory & Rates
2355 W. Pinnacle Peak Rd., Phoenix, AZ 85027

APPROVED FOR FILING
 DECISION #: 76162

General Wastewater Service
(continued)

Step 1 Rates Continued:

Current Rate Schedules		Monthly Minimum Charge	Commodity Rates (per 1,000 gallons)	Maximum Gallons at Commodity Rates
Sun City West Wastewater				
B1S1A	Residential S Unit 5/8 x 3/4 Inch	\$ 37.59	-N/A-	-N/A-
B1S1B	Residential S Unit 1 Inch	\$ 37.59	-N/A-	-N/A-
B1S1D	Residential S Unit=> 2 Inch	\$ 37.59	-N/A-	-N/A-
B1S1N	Residential S Unit Non Water	\$ 37.59	-N/A-	-N/A-
B1S2A	Condos	\$ 37.59	-N/A-	-N/A-
B2S1A	Commercial S Unit 5/8 x 3/4 Inch	\$ 29.21	\$ 2.9711	5,000
B2S1B	Commercial S Unit 1 Inch	\$ 73.12	\$ 2.9711	12,500
B2S1C	Commercial S Unit 1 1/2 Inch	\$ 102.37	\$ 2.9711	25,000
B2S1D	Commercial S Unit 2 Inch	\$ 146.28	\$ 2.9711	40,000
B2S1E	Commercial S Unit >2 Inch	\$ 146.28	\$ 2.9711	All Usage
B2S1N	Commercial S Unit No Water	\$ 188.16	-N/A-	-N/A-
B2S1O	Commercial Laundry Non-Water	\$ 752.66	-N/A-	-N/A-
B2S1P	Commercial Hotel Non-Water	\$ 1,152.98	-N/A-	-N/A-
B2S2B	Commercial Multi Unit 1 Inch	\$ 73.12	\$ 2.9711	12,500
B2S2C	Commercial Multi Unit 1 1/2 Inch	\$ 102.37	\$ 2.9711	25,000
B2S2D	Commercial Multi Unit 2 Inch	\$ 143.71	\$ 2.9711	40,000
B2S2E	Commercial Multi Unit >2 Inch	\$ 143.71	\$ 2.9711	All Usage
B2S7D	Commercial Large User	\$ 143.71	\$ 2.9711	All Usage
Sun City Wastewater				
A1S1A	Residential S Unit 5/8 Inch	\$ 27.13	-N/A-	-N/A-
A1S1B	Residential S Unit 1 Inch	\$ 27.13	-N/A-	-N/A-
A1S1C	Residential S Unit 1 1/2 Inch	\$ 27.13	-N/A-	-N/A-
A1S1D	Residential M Unit=> 2 Inch	\$ 27.13	-N/A-	-N/A-
A1S1N	Residential S Unit Non Water	\$ 27.13	-N/A-	-N/A-
A1S2A	Residential Multi 1 1/2 Inch to 2 Inch	\$ 27.13	-N/A-	-N/A-
A1S2N	Residential Multi Family	\$ 27.13	-N/A-	-N/A-
A2MSP	Mobile Home	\$ 11,389.34	\$ 2.8884	All Usage
A2S1A	Commercial S Unit 5/8 x 3/4 Inch	\$ 28.24	\$ 2.8884	5,000
A2S1B	Commercial S Unit 1 Inch	\$ 70.69	\$ 2.8884	12,500
A2S1C	Commercial S Unit 1 1/2 Inch	\$ 99.59	\$ 2.8884	25,000
A2S1D	Commercial S Unit 2 Inch	\$ 142.65	\$ 2.8884	40,000
A2S1E	Commercial S Unit > 2 Inch	\$ 142.65	\$ 2.8884	All Usage
A2S1N	Commercial S Unit Non Water	\$ 182.58	-N/A-	-N/A-
A2S2A	Commercial M Unit 5/8 x 3/4 Inch	\$ 28.24	\$ 2.8884	5,000
A2S2B	Commercial M Unit 1 Inch	\$ 70.69	\$ 2.8884	12,500
A2S2C	Commercial M Unit 1 1/2 Inch	\$ 99.59	\$ 2.8884	25,000
A2S2D	Commercial M Unit 2 Inch	\$ 142.65	\$ 2.8884	40,000
A2S2E	Commercial M Unit >2 Inch	\$ 142.65	\$ 2.8884	All Usage
A2S7D	Commercial Large User =>2	\$ 142.65	\$ 2.8884	All Usage

(continued on Sheet 1b)

ISSUED: June 30, 2017 EFFECTIVE: July 1, 2017
 Month Day Year Month Day Year
 ISSUED BY: Sheryl Hubbard, Director, Regulatory & Rates
2355 W. Pinnacle Peak Rd., Phoenix, AZ 85027

APPROVED FOR FILING

DECISION #: 76162

General Wastewater Service
(continued)

Step 2 Rates: Effective July 1, 2018 through June 30, 2019

Current Rate Schedules		Monthly Minimum Charge	Commodity Rates (per 1,000 gallons)	Maximum Gallons at Commodity Rates
Agua Fria Wastewater				
C1MS1	Residential	\$ 56.50	-N/A-	-N/A-
C2MS1	Commercial 5/8 Inch	\$ 29.31	\$ 2.9722	5,000
C2MS2	Commercial 3/4 Inch	\$ 29.31	\$ 2.9722	5,000
C2MS3	Commercial 1 Inch	\$ 73.28	\$ 2.9722	12,500
C2MS4	Commercial LG 1 1/2 Inch	\$ 102.57	\$ 2.9722	25,000
C2MS5	Commercial LG 2 Inch	\$ 146.54	\$ 2.9722	40,000
Anthem Wastewater				
E1MS1	Residential	\$ 55.39	-N/A-	-N/A-
E2MS1	Commercial 5/8 Inch	\$ 29.31	\$ 2.9722	5,000
E2MS2	Commercial 3/4 Inch	\$ 29.31	\$ 2.9722	5,000
E2MS3	Commercial 1 Inch	\$ 73.28	\$ 2.9722	12,500
E2MS4	Commercial 1 1/2 Inch	\$ 102.57	\$ 2.9722	25,000
E2MS5	Commercial 2 Inch	\$ 146.54	\$ 2.9722	40,000
E2MSA	Commercial LG 1 Inch	\$ 73.28	\$ 2.9722	12,500
E2MSB	Commercial LG 1 1/2 Inch	\$ 102.57	\$ 2.9722	25,000
E2MSC	Commercial LG 2 Inch	\$ 146.54	\$ 2.9722	40,000
E5M2	Wholesale (Phoenix) OWU	-N/A-	\$ 3.9232	All Usage
Mohave Wastewater				
P1MS1	Residential	\$ 52.36	-N/A-	-N/A-
P2MS1	Commercial	\$ 188.17	-N/A-	-N/A-
P2MS4	Commercial LG	\$ 146.54	\$ 2.9722	All Usage
P4MS1	OPA	\$ 38.59	-N/A-	-N/A-
Sun City West Wastewater				
B1S1A	Residential S Unit 5/8 x 3/4 Inch	\$ 37.59	-N/A-	-N/A-
B1S1B	Residential S Unit 1 Inch	\$ 37.59	-N/A-	-N/A-
B1S1D	Residential S Unit=> 2 Inch	\$ 37.59	-N/A-	-N/A-
B1S1N	Residential S Unit Non Water	\$ 37.59	-N/A-	-N/A-
B1S2A	Condos	\$ 37.59	-N/A-	-N/A-
B2S1A	Commercial S Unit 5/8 x 3/4 Inch	\$ 29.31	\$ 2.9722	5,000
B2S1B	Commercial S Unit 1 Inch	\$ 73.28	\$ 2.9722	12,500
B2S1C	Commercial S Unit 1 1/2 Inch	\$ 102.57	\$ 2.9722	25,000
B2S1D	Commercial S Unit 2 Inch	\$ 146.54	\$ 2.9722	All Usage
B2S1E	Commercial S Unit >2 Inch	\$ 146.54	\$ 2.9722	All Usage
B2S1N	Commercial S Unit No Water	\$ 188.17	-N/A-	-N/A-
B2S1O	Commercial Laundry Non-Water	\$ 752.67	-N/A-	-N/A-
B2S1P	Commercial Hotel Non-Water	\$ 1,152.99	-N/A-	-N/A-
B2S2B	Commercial Multi Unit 1 Inch	\$ 73.28	\$ 2.9722	12,500
B2S2C	Commercial Multi Unit 1 1/2 Inch	\$ 102.57	\$ 2.9722	25,000
B2S2D	Commercial Multi Unit 2 Inch	\$ 146.54	\$ 2.9722	40,000
B2S2E	Commercial Multi Unit >2 Inch	\$ 146.54	\$ 2.9722	All Usage
B2S7D	Commercial Large User	\$ 146.54	\$ 2.9722	All Usage

(continued on Sheet 1c)

ISSUED: June 30, 2017 EFFECTIVE: July 1, 2017
Month Day Year Month Day Year
 ISSUED BY: Sheryl Hubbard, Director, Regulatory & Rates
2355 W. Pinnacle Peak Rd., Phoenix, AZ 85027

APPROVED FOR FILING

DECISION #: 76162

General Wastewater Service
(continued)

Step 2 Rates Continued:

Current Rate Schedules		Monthly Minimum Charge	Commodity Rates (per 1,000 gallons)	Maximum Gallons at Commodity Rates
	Sun City Wastewater			
A1S1A	Residential S Unit 5/8 Inch	\$ 29.74	-N/A-	-N/A-
A1S1B	Residential S Unit 1 Inch	\$ 29.74	-N/A-	-N/A-
A1S1C	Residential S Unit 1 1/2 Inch	\$ 29.74	-N/A-	-N/A-
A1S1D	Residential M Unit=> 2 Inch	\$ 29.74	-N/A-	-N/A-
A1S1N	Residential S Unit Non Water	\$ 29.74	-N/A-	-N/A-
A1S2A	Residential Multi 1 1/2 Inch to 2 Inch	\$ 29.74	-N/A-	-N/A-
A1S2N	Residential Multi Family	\$ 29.74	-N/A-	-N/A-
A2MSP	Mobile Home	\$ 11,546.82	\$ 2.9722	All Usage
A2S1A	Commercial S Unit 5/8 x 3/4 Inch	\$ 29.31	\$ 2.9722	5,000
A2S1B	Commercial S Unit 1 Inch	\$ 73.28	\$ 2.9722	12,500
A2S1C	Commercial S Unit 1 1/2 Inch	\$ 102.57	\$ 2.9722	25,000
A2S1D	Commercial S Unit 2 Inch	\$ 146.54	\$ 2.9722	40,000
A2S1E	Commercial S Unit > 2 Inch	\$ 146.54	\$ 2.9722	All Usage
A2S1N	Commercial S Unit Non Water	\$ 188.17	-N/A-	-N/A-
A2S2A	Commercial M Unit 5/8 x 3/4 Inch	\$ 29.31	\$ 2.9722	5,000
A2S2B	Commercial M Unit 1 Inch	\$ 73.28	\$ 2.9722	12,500
A2S2C	Commercial M Unit 1 1/2 Inch	\$ 102.57	\$ 2.9722	25,000
A2S2D	Commercial M Unit 2 Inch	\$ 146.54	\$ 2.9722	40,000
A2S2E	Commercial M Unit >2 Inch	\$ 146.54	\$ 2.9722	All Usage
A2S7D	Commercial Large User =>2 Inch	\$ 146.54	\$ 2.9722	All Usage

(continued on Sheet 1d)

ISSUED: June 30, 2017 EFFECTIVE: July 1, 2017
Month Day Year Month Day Year
 ISSUED BY: Sheryl Hubbard, Director, Regulatory & Rates
2355 W. Pinnacle Peak Rd., Phoenix, AZ 85027

APPROVED FOR FILING

DECISION #: 76162

General Wastewater Service
(continued)

Step 3 Rates: Effective July 1, 2019 through June 30, 2020

Current Rate Schedules		Monthly Minimum Charge	Commodity Rates (per 1,000 gallons)	Maximum Gallons at Commodity Rates
Agua Fria Wastewater				
C1MS1	Residential	\$ 50.53	-N/A-	-N/A-
C2MS1	Commercial 5/8 Inch	\$ 29.31	\$ 2.9722	5,000
C2MS2	Commercial 3/4 Inch	\$ 29.31	\$ 2.9722	5,000
C2MS3	Commercial 1 Inch	\$ 73.28	\$ 2.9722	12,500
C2MS4	Commercial LG 1 1/2 Inch	\$ 102.57	\$ 2.9722	25,000
C2MS5	Commercial LG 2 Inch	\$ 146.54	\$ 2.9722	40,000
Anthem Wastewater				
E1MS1	Residential	\$ 51.63	-N/A-	-N/A-
E2MS1	Commercial 5/8 Inch	\$ 29.31	\$ 2.9722	5,000
E2MS2	Commercial 3/4 Inch	\$ 29.31	\$ 2.9722	5,000
E2MS3	Commercial 1 Inch	\$ 73.28	\$ 2.9722	12,500
E2MS4	Commercial 1 1/2 Inch	\$ 102.57	\$ 2.9722	25,000
E2MS5	Commercial 2 Inch	\$ 146.54	\$ 2.9722	40,000
E2MSA	Commercial LG 1 Inch	\$ 73.28	\$ 2.9722	12,500
E2MSB	Commercial LG 1 1/2 Inch	\$ 102.57	\$ 2.9722	25,000
E2MSC	Commercial LG 2 Inch	\$ 146.54	\$ 2.9722	40,000
E5M2	Wholesale (Phoenix) OWU	-N/A-	\$ 3.9233	All Usage
Mohave Wastewater				
P1MS1	Residential	\$ 47.44	-N/A-	-N/A-
P2MS1	Commercial	\$ 188.17	-N/A-	-N/A-
P2MS4	Commercial LG	\$ 146.54	\$ 2.9722	All Usage
P4MS1	OPA	\$ 38.59	-N/A-	-N/A-
Sun City West Wastewater				
B1S1A	Residential S Unit 5/8 x 3/4 Inch	\$ 37.59	-N/A-	-N/A-
B1S1B	Residential S Unit 1 Inch	\$ 37.59	-N/A-	-N/A-
B1S1D	Residential S Unit=> 2 Inch	\$ 37.59	-N/A-	-N/A-
B1S1N	Residential S Unit Non Water	\$ 37.59	-N/A-	-N/A-
B1S2A	Condos	\$ 37.59	-N/A-	-N/A-
B2S1A	Commercial S Unit 5/8 x 3/4 Inch	\$ 29.31	\$ 2.9722	5,000
B2S1B	Commercial S Unit 1 Inch	\$ 73.28	\$ 2.9722	12,500
B2S1C	Commercial S Unit 1 1/2 Inch	\$ 102.57	\$ 2.9722	25,000
B2S1D	Commercial S Unit 2 Inch	\$ 146.54	\$ 2.9722	40,000
B2S1E	Commercial S Unit >2 Inch	\$ 146.54	\$ 2.9722	All Usage
B2S1N	Commercial S Unit No Water	\$ 188.17	-N/A-	-N/A-
B2S1O	Commercial Laundry Non-Water	\$ 752.67	-N/A-	-N/A-
B2S1P	Commercial Hotel Non-Water	\$ 1,152.99	-N/A-	-N/A-
B2S2B	Commercial Multi Unit 1 Inch	\$ 73.28	\$ 2.9722	12,500
B2S2C	Commercial Multi Unit 1 1/2 Inch	\$ 102.57	\$ 2.9722	25,000
B2S2D	Commercial Multi Unit 2 Inch	\$ 146.54	\$ 2.9722	40,000
B2S2E	Commercial Multi Unit >2 Inch	\$ 146.54	\$ 2.9722	All Usage
B2S7D	Commercial Large User	\$ 146.54	\$ 2.9722	All Usage

(continued on Sheet 1e)

ISSUED: June 30, 2017 EFFECTIVE: July 1, 2017
 Month Day Year Month Day Year
 ISSUED BY: Sheryl Hubbard, Director, Regulatory & Rates
2355 W. Pinnacle Peak Rd., Phoenix, AZ 85027

APPROVED FOR FILING

DECISION #: 76162

General Wastewater Service
(continued)

Step 3 Rates Continued:

Current Rate Schedules		Monthly Minimum Charge	Commodity Rates (per 1,000 gallons)	Maximum Gallons at Commodity Rates
	Sun City Wastewater			
A1S1A	Residential S Unit 5/8 Inch	\$ 32.36	-N/A-	-N/A-
A1S1B	Residential S Unit 1 Inch	\$ 32.36	-N/A-	-N/A-
A1S1C	Residential S Unit 1 1/2 Inch	\$ 32.36	-N/A-	-N/A-
A1S1D	Residential M Unit=> 2 Inch	\$ 32.36	-N/A-	-N/A-
A1S1N	Residential S Unit Non Water	\$ 32.36	-N/A-	-N/A-
A1S2A	Residential Multi 1 1/2 Inch to 2 Inch	\$ 32.36	-N/A-	-N/A-
A1S2N	Residential Multi Family	\$ 32.36	-N/A-	-N/A-
A2MSP	Mobile Home	\$ 11,546.96	\$ 2.9722	All Usage
A2S1A	Commercial S Unit 5/8 x 3/4 Inch	\$ 29.31	\$ 2.9722	5,000
A2S1B	Commercial S Unit 1 Inch	\$ 73.28	\$ 2.9722	12,500
A2S1C	Commercial S Unit 1 1/2 Inch	\$ 102.57	\$ 2.9722	25,000
A2S1D	Commercial S Unit 2 Inch	\$ 146.54	\$ 2.9722	40,000
A2S1E	Commercial S Unit > 2 Inch	\$ 146.54	\$ 2.9722	All Usage
A2S1N	Commercial S Unit Non Water	\$ 188.17	-N/A-	-N/A-
A2S2A	Commercial M Unit 5/8 x 3/4 Inch	\$ 29.31	\$ 2.9722	5,000
A2S2B	Commercial M Unit 1 Inch	\$ 73.28	\$ 2.9722	12,500
A2S2C	Commercial M Unit 1 1/2 Inch	\$ 102.57	\$ 2.9722	25,000
A2S2D	Commercial M Unit 2 Inch	\$ 146.54	\$ 2.9722	40,000
A2S2E	Commercial M Unit >2 Inch	\$ 146.54	\$ 2.9722	All Usage
A2S7D	Commercial Large User =>2 Inch	\$ 146.54	\$ 2.9722	All Usage

(continued on Sheet 1f)

ISSUED: June 30, 2017 EFFECTIVE: July 1, 2017
Month Day Year Month Day Year
 ISSUED BY: Sheryl Hubbard, Director, Regulatory & Rates
2355 W. Pinnacle Peak Rd., Phoenix, AZ 85027

APPROVED FOR FILING

DECISION #: 76162

General Wastewater Service
(continued)

Step 4 Rates: Effective July 1, 2020 through June 30, 2021

Current Rate Schedules		Monthly Minimum Charge	Commodity Rates (per 1,000 gallons)	Maximum Gallons at Commodity Rates
Agua Fria Wastewater				
C1MS1	Residential	\$ 44.55	-N/A-	-N/A-
C2MS1	Commercial 5/8 Inch	\$ 29.31	\$ 2.9722	5,000
C2MS2	Commercial ¾ Inch	\$ 29.31	\$ 2.9722	5,000
C2MS3	Commercial 1 Inch	\$ 73.28	\$ 2.9722	12,500
C2MS4	Commercial LG 1 ½ Inch	\$ 102.57	\$ 2.9722	25,000
C2MS5	Commercial LG 2 Inch	\$ 146.54	\$ 2.9722	40,000
Anthem Wastewater				
E1MS1	Residential	\$ 47.89	-N/A-	-N/A-
E2MS1	Commercial 5/8 Inch	\$ 29.31	\$ 2.9722	5,000
E2MS2	Commercial ¾ Inch	\$ 29.31	\$ 2.9722	5,000
E2MS3	Commercial 1 Inch	\$ 73.28	\$ 2.9722	12,500
E2MS4	Commercial 1 ½ Inch	\$ 102.57	\$ 2.9722	25,000
E2MS5	Commercial 2 Inch	\$ 146.54	\$ 2.9722	40,000
E2MSA	Commercial LG 1 Inch	\$ 73.28	\$ 2.9722	12,500
E2MSB	Commercial LG 1 ½ Inch	\$ 102.57	\$ 2.9722	25,000
E2MSC	Commercial LG 2 Inch	\$ 146.54	\$ 2.9722	40,000
E5M2	Wholesale (Phoenix) OWU	-N/A-	\$ 3.9233	All Usage
Mohave Wastewater				
P1MS1	Residential	\$ 42.52	-N/A-	-N/A-
P2MS1	Commercial	\$ 188.17	-N/A-	-N/A-
P2MS4	Commercial LG	\$ 146.54	\$ 2.9722	All Usage
P4MS1	OPA	\$ 38.59	-N/A-	-N/A-
Sun City West Wastewater				
B1S1A	Residential S Unit 5/8 x ¾ Inch	\$ 37.59	-N/A-	-N/A-
B1S1B	Residential S Unit 1 Inch	\$ 37.59	-N/A-	-N/A-
B1S1D	Residential S Unit=> 2 Inch	\$ 37.59	-N/A-	-N/A-
B1S1N	Residential S Unit Non Water	\$ 37.59	-N/A-	-N/A-
B1S2A	Condos	\$ 37.59	-N/A-	-N/A-
B2S1A	Commercial S Unit 5/8 x ¾ Inch	\$ 29.31	\$ 2.9722	5,000
B2S1B	Commercial S Unit 1 Inch	\$ 73.28	\$ 2.9722	12,500
B2S1C	Commercial S Unit 1 ½ Inch	\$ 102.57	\$ 2.9722	25,000
B2S1D	Commercial S Unit 2 Inch	\$ 146.54	\$ 2.9722	All Usage
B2S1E	Commercial S Unit >2 Inch	\$ 146.54	\$ 2.9722	All Usage
B2S1N	Commercial S Unit No Water	\$ 188.17	-N/A-	-N/A-
B2S1O	Commercial Laundry Non-Water	\$ 752.67	-N/A-	-N/A-
B2S1P	Commercial Hotel Non-Water	\$ 1,152.99	-N/A-	-N/A-
B2S2B	Commercial Multi Unit 1 Inch	\$ 73.28	\$ 2.9722	12,500
B2S2C	Commercial Multi Unit 1 ½ Inch	\$ 102.57	\$ 2.9722	25,000
B2S2D	Commercial Multi Unit 2 Inch	\$ 146.54	\$ 2.9722	40,000
B2S2E	Commercial Multi Unit >2 Inch	\$ 146.54	\$ 2.9722	All Usage
B2S7D	Commercial Large User	\$ 146.54	\$ 2.9722	All Usage

(continued on Sheet 1g)

ISSUED: June 30, 2017 EFFECTIVE: July 1, 2017
 Month Day Year Month Day Year
 ISSUED BY: Sheryl Hubbard, Director, Regulatory & Rates
2355 W. Pinnacle Peak Rd., Phoenix, AZ 85027

APPROVED FOR FILING
 DECISION #: 76162

General Wastewater Service
(continued)

Step 4 Rates 4 Continued:

Current Rate Schedules		Monthly Minimum Charge	Commodity Rates (per 1,000 gallons)	Maximum Gallons at Commodity Rates
	Sun City Wastewater			
A1S1A	Residential S Unit 5/8 Inch	\$ 34.98	-N/A-	-N/A-
A1S1B	Residential S Unit 1 Inch	\$ 34.98	-N/A-	-N/A-
A1S1C	Residential S Unit 1 1/2 Inch	\$ 34.98	-N/A-	-N/A-
A1S1D	Residential M Unit=> 2 Inch	\$ 34.98	-N/A-	-N/A-
A1S1N	Residential S Unit Non Water	\$ 34.98	-N/A-	-N/A-
A1S2A	Residential Multi 1 1/2 Inch to 2 Inch	\$ 34.98	-N/A-	-N/A-
A1S2N	Residential Multi Family	\$ 34.98	-N/A-	-N/A-
A2MSP	Mobile Home	\$ 11,546.96	\$ 2.9722	All Usage
A2S1A	Commercial S Unit 5/8 x 3/4 Inch	\$ 29.31	\$ 2.9722	5,000
A2S1B	Commercial S Unit 1 Inch	\$ 73.28	\$ 2.9722	12,500
A2S1C	Commercial S Unit 1 1/2 Inch	\$ 102.57	\$ 2.9722	25,000
A2S1D	Commercial S Unit 2 Inch	\$ 146.54	\$ 2.9722	40,000
A2S1E	Commercial S Unit > 2 Inch	\$ 146.54	\$ 2.9722	All Usage
A2S1N	Commercial S Unit Non Water	\$ 188.17	-N/A-	-N/A-
A2S2A	Commercial M Unit 5/8 x 3/4 Inch	\$ 29.31	\$ 2.9722	5,000
A2S2B	Commercial M Unit 1 Inch	\$ 73.28	\$ 2.9722	12,500
A2S2C	Commercial M Unit 1 1/2 Inch	\$ 102.57	\$ 2.9722	25,000
A2S2D	Commercial M Unit 2 Inch	\$ 146.54	\$ 2.9722	40,000
A2S2E	Commercial M Unit >2 Inch	\$ 146.54	\$ 2.9722	All Usage
A2S7D	Commercial Large User =>2 Inch	\$ 146.54	\$ 2.9722	All Usage

(continued on Sheet 1h)

ISSUED: June 30, 2017 EFFECTIVE: July 1, 2017
Month Day Year Month Day Year
 ISSUED BY: Sheryl Hubbard, Director, Regulatory & Rates
2355 W. Pinnacle Peak Rd., Phoenix, AZ 85027

APPROVED FOR FILING
 DECISION #: 76162

**General Wastewater Service
(continued)**

Step 5 Rates: Effective July 1, 2021 and beyond

Consolidated Rate Schedule		Monthly Minimum Charge	Commodity Rates (per 1,000 gallons)	Maximum Gallons at Commodity Rates
X1MS1	Residential Units	\$ 38.59	-N/A-	-N/A-
X2MS1	Commercial Unit 5/8 Inch	\$ 29.31	\$ 2.9722	5,000
X2MS1	Commercial Unit 3/4 Inch	\$ 29.31	\$ 2.9722	5,000
X2MS3	Commercial Unit 1 Inch	\$ 73.28	\$ 2.9722	12,500
X2MS4	Commercial Unit LG 1 1/2 Inch	\$ 102.57	\$ 2.9722	25,000
X2MS5	Commercial Unit LG 2 Inch	\$ 146.54	\$ 2.9722	40,000
X2MS6	Commercial Unit LG > 2 Inch	\$ 146.54	\$ 2.9722	All Usage
X2N1	Commercial Single Unit No Water	\$ 188.17	-N/A-	-N/A-
X2N2	Commercial Laundry Non-Water	\$ 752.67	-N/A-	-N/A-
X2N3	Commercial Hotel Non-Water	\$ 1,152.99	-N/A-	-N/A-
X2MSP	Mobile Home	\$ 11,546.96	\$ 2.9722	All Usage
X4MS1	OPA	\$ 38.59	-N/A-	-N/A-
X5MS2	Wholesale OWU	-N/A-	\$ 3.9233	All Usage

Terms and Conditions

Wastewater service provided under this rate schedule is subject to Arizona Administrative Code Rules and Regulations applicable to Wastewater Service and may be subject to the Company's Service Charges set forth in Rate Schedule Service Charges and adjustor mechanisms included in the Company's tariffs on file with the Arizona Corporation Commission.

Wastewater services under this schedule are for the exclusive use of the customer and wastewater services shall not be resold or provided to others.

In addition to the collection of regular rates, the Company will collect from its customers a proportionate share of any privilege, sales or use tax, or other imposition based on the gross revenues received by the Company. Per Commission Rule 14-2-608 (D)(5).

A 1 1/2% late payment penalty will be applied to account balances not paid within fifteen (15) days after the postmark date of the bill in accordance with Arizona Administrative Code R14-2-608(F)(3).

ISSUED: June 30, 2017 EFFECTIVE: July 1, 2017
Month Day Year Month Day Year
 ISSUED BY: Sheryl Hubbard, Director, Regulatory & Rates
2355 W. Pinnacle Peak Rd., Phoenix, AZ 85027

APPROVED FOR FILING
 DECISION #: 76162

Annual Fee for Industrial Discharge Service

Availability

Applicable to all customers covered by this District's Rule No. 10 "USE OF SANITARY WASTEWATER BY INDUSTRIAL DISCHARGERS" and who have entered an Industrial Discharge Service Agreement pursuant to Rule No. 10 per EPCOR Water Arizona, Inc.'s Arizona Wastewater District's Rules and Regulations.

Rates

For those customers consuming an amount of water less than or equal to 50,000 gallons per month through one or more water meters to the same facility, inclusive of meters used for irrigation;

\$ 500.00 per year

For those customers consuming more than 50,000 gallons per month of water through one or more water meters to the same facility, inclusive of meters used for irrigation;

\$1,000.00 per year

Special-Conditions

Charges shall be non-refundable and shall be assessed in advance each January by the Company by special billing.

For new Customers receiving this service, a prorated charge shall be assessed.

ISSUED: June 30, 2017 EFFECTIVE: July 1, 2017
Month Day Year Month Day Year
ISSUED BY: Sheryl Hubbard, Director, Regulatory & Rates
2355 W. Pinnacle Peak Rd., Phoenix, AZ 85027

APPROVED FOR FILING
DECISION #: 76162

ORIGINAL

Off-Site Facilities Hook-Up Fee (Wastewater)
Arizona Wastewater District

I. Purpose and Applicability

The purpose of the off-site facilities hook-up fees payable to EPCOR Water Arizona, Inc. – Arizona Wastewater District (“the Company”) pursuant to this tariff is to equitably apportion the costs of constructing additional off-site facilities to provide wastewater treatment plant facilities among all new service laterals. These charges are applicable to all new service laterals established after the effective date of this tariff. The charges are one-time charges and are payable as a condition to Company’s establishment of service, as more particularly provided below.

II. Definitions

Unless the context otherwise requires, the definitions set forth in R-14-2-601 of the Arizona Corporation Commission’s (“Commission”) rules and regulations governing wastewater utilities shall apply interpreting this tariff schedule.

“Applicant” means any party entering into an agreement with Company for the installation of wastewater facilities to serve new service laterals, and may include Developers and/or Builder of new residential subdivisions.

“Company” means EPCOR Water Arizona, Inc. – Arizona Wastewater District.

“Collection Main Extension Agreement” means any agreement whereby an Applicant, Developer and/or Builder agrees to advance the costs of the installation of wastewater facilities to the Company to serve new service laterals, or install wastewater facilities to serve new service laterals and transfer ownership of such wastewater facilities to the Company, which agreement does not require the approval of the Commission pursuant to A.A.C. R-14-2-606, and shall have the same meaning as “Wastewater Facilities Agreement.”

“Off-Site Facilities” means the wastewater treatment plant, sludge disposal facilities, effluent disposal facilities and related appurtenances for proper operation, including engineering and design costs. Off-site facilities may also include lift stations, transportation mains and related appurtenances necessary for proper operation if these facilities are not for the exclusive use of the applicant and benefit the entire wastewater system.

“Service Lateral” means and includes all service laterals for single-family residential or other uses.

III. Off-Site Facilities Hook-Up Fee

For each new service lateral, the Company shall collect an off-site facilities hook-up fee as listed in the following table

TREATMENT PLANT HOOK-UP FEE TARIFF TABLE	
Service Lateral Size	Fee
4-inch	\$ 765
6-inch	\$ 1,721
8-inch	\$ 3,060
10-inch	\$ 4,781

(continued on Sheet 3a)

ISSUED: June 30, 2017 EFFECTIVE: July 1, 2017
Month Day Year Month Day Year
ISSUED BY: Sheryl Hubbard, Director, Regulatory & Rates
2355 W. Pinnacle Peak Rd., Phoenix, AZ 85027

APPROVED FOR FILING
DECISION #: 76162

Off-Site Facilities Hook-Up Fee (Wastewater)
Arizona Wastewater District
(continued)

IV. Terms and Conditions

- (A). Assessment of One Time Off-Site Facilities Hook-Up Fee: The off-site facilities hook-up fee may be assessed only once per parcel, service lateral, or lot within a subdivision (similar to a service lateral installation charge).
- (B). Use of Off-Site Facilities Hook-Up Fee: Off-site facilities hook-up fees may only be used to pay for capital items of off-site facilities, or for repayment of loans obtained for installation of off-site facilities. Off-site hook-up fees shall not be used for repairs, maintenance, or operational purposes.
- (C). Time of Payment:
- (1) In the event that the person or entity that will be constructing improvements ("Applicant", "Developer" or "Builder") is otherwise required to enter into a Collection Main Extension Agreement, payment of the fees required hereunder shall be made by the Applicant, Developer or Builder prior to when acceptance is issued for the on-site wastewater facilities constructed to serve the improvement.
- (2) In the event that the Applicant, Developer or Builder for services is not required to enter into a Collection Main Extension Agreement, the charges hereunder shall be due and payable at the time wastewater service is requested for the property.

(continued on Sheet 3b)

ISSUED: June 30, 2017 EFFECTIVE: July 1, 2017
Month Day Year Month Day Year
ISSUED BY: Sheryl Hubbard, Director, Regulatory & Rates
2355 W. Pinnacle Peak Rd., Phoenix, AZ 85027

APPROVED FOR FILING

DECISION #: 76162

ORIGINAL

(Name of Company)

Arizona Wastewater District

(Name of Service Area)

Off-Site Facilities Hook-Up Fee (Wastewater)
Arizona Wastewater District
(continued)

- (D). Off-Site Facilities Construction by Developer: Company and Applicant, Developer, or Builder may agree to construction of off-site facilities necessary to serve a particular development by Applicant, Developer or Builder, which facilities are then conveyed to Company. In that event, Company shall credit the total cost of such off-site facilities as an offset to off-site hook-up fees due under this Tariff. If the total cost of the off-site facilities constructed by Applicant, Developer or Builder and conveyed to Company is less than the applicable off-site hook-up fees under this Tariff, Applicant, Developer or Builder shall pay the remaining amount of off-site hook-up fees owed hereunder. If the total cost of the off-site facilities contributed by Applicant, Developer or Builder and conveyed to Company is more than the applicable off-site hook-up fees under this Tariff, Applicant, Developer or Builder shall be refunded the difference upon acceptance of the off-site facilities by the Company.
- (E). Failure to Pay Charges; Delinquent Payments: The Company will not be obligated to provide wastewater service to any Developer, Builder or other applicant for service in the event that the Developer, Builder or other applicant for service has not paid in full all charges hereunder. Under no circumstances will the Company connect service or otherwise allow service to be established if the entire amount of any payment has not been paid.
- (F). Off-Site Hook-Up Fees Non-refundable: The amounts collected by the Company pursuant to the off-site facilities hook-up fee tariff shall be non-refundable contributions in aid of construction.
- (G). Use of Off-Site Hook-Up Fees Received: All funds collected by the Company as off-site facilities hook-up fees shall be deposited into a separate interest bearing trust account and used solely for the purpose of paying for the costs of off-site facilities, including repayment of loans obtained for the installation of off-site facilities.
- (H). Off-Site Facilities Hook-Up Fee in Addition to On-Site Facilities: The off-site facilities hook-up fee shall be in addition to any costs associated with the construction of on-site facilities under a Collection Main Extension Agreement.
- (I). Disposition of Excess Funds: After all necessary and desirable off-site facilities are constructed utilizing funds collected pursuant to the off-site facilities hook-up fees, or if the off-site facilities hook-up fee has been terminated by order of the Arizona Corporation Commission, any funds remaining in the trust shall be refunded. The manner of the refund shall be determined by the Commission at the time a refund becomes necessary.
- (J). Status Reporting Requirements to the Commission: The Company shall submit a calendar year Off-Site Facilities Hook-Up Fee status report each January 31st to Docket Control for the prior twelve (12) month period, beginning January 31, 2012 until the hook-up fee tariff is no longer in effect. This status report shall contain a list of all customers that have paid the hook-up fee tariff, the amount each has paid, the amount of money spent from the account, the amount of interest earned on the tariff account, and a list of all facilities that have been installed with the tariff during the 12 month period.

ISSUED: June 30, 2017
 Month Day Year

EFFECTIVE: July 1, 2017
 Month Day Year

ISSUED BY: Sheryl Hubbard, Director, Regulatory & Rates
2355 W. Pinnacle Peak Rd., Phoenix, AZ 85027

APPROVED FOR FILING

DECISION #: 76162

SERVICE CHARGES

This District is authorized to charge the following Service Charges:

Service Establishment, Reestablishment, Reconnection, and Miscellaneous Charges

Establishment of Service	\$35.00
Reestablishment of Service	(c)
Reconnection of Service (Delinquent)	\$35.00
Deposit	(a)
Deposit Interest	(a)
NSF Check	\$25.00
Deferred Payment (per month)	1.5%
Late Payment Fee (per month)	1.5%
After Hours Service Charge (b)	\$35.00

- (a) Per Commission Rules R-14-2-603.B.
- (b) After Hours Service: After regular working hours, on Saturday, Sunday or holidays if at the customer's request.
- (c) Monthly minimum times number of months disconnected from the system at the same location where the same customer had ordered a service disconnection within the preceding 12-month period.

In addition to the collection of regular rates, the utility will collect from its customers a proportionate share of any privilege, sales or use tax, or other imposition based on the gross revenues received by the utility. Per Commission Rule 14-2-608(D)(5).

Service Line Connection Charges

Residential	At Cost
Commercial	At Cost
School	At Cost
Multiple Dwelling	At Cost
Mobile Home Park	At Cost
Effluent	At Cost

Pursuant to Commission Rules R14-2-605(B)(2)

ISSUED: June 30, 2017 EFFECTIVE: July 1, 2017
Month Day Year Month Day Year
ISSUED BY: Sheryl Hubbard, Director, Regulatory & Rates
2355 W. Pinnacle Peak Rd., Phoenix, AZ 85027

APPROVED FOR FILING
DECISION #: 76162

Effluent

Availability

Available to large turf and landscape irrigators for use on golf courses, lakes, school grounds, park lands, rights of ways, and similar large open spaces when effluent is available. Also available to land developers and their contractors and sub-contractors for use on large construction projects which require significant amounts of dirt moving, grading, trenching or other effluent intensive construction activities when effluent is available.

Schedule of Charges

Effluent Rates: Effective July 1, 2017 and beyond

Current Rate Schedules		Tier One		
		Monthly Minimum Charge	Commodity Rates (per 1,000 gallons)	Upper Limit
	Agua Fria Wastewater			
W7MS	Effluent	\$ 0.00	\$0.77	Infinite
	Anthem Wastewater			
E7MS	Effluent	\$ 0.00	\$0.77	Infinite
	Mohave Wastewater			
P7A1	Effluent (Acre-Foot)	\$ 0.00	227.79	Infinite

Special Conditions

The treated wastewater provided under this tariff is reclaimed sewage effluent and it is not suitable for human consumption or bodily contact. Service provided under this tariff should be used only for irrigation. Deliveries are subject to interruption, curtailment, or scheduling as necessary to match demands with available supplies.

Terms and Conditions

Treated wastewater service provided under this rate schedule is subject to this District's Rules and Regulations and may be subject to this District's Service Charges set forth in Rate Schedule Service Charges and adjustor mechanisms included in the Company's tariffs on file with the Arizona Corporation Commission.

Wastewater services under this schedule are for the exclusive use of the customer and wastewater services shall not be resold or provided to others.

In addition to the collection of regular rates, the Company will collect from its customers a proportionate share of any privilege, sales or use tax, or other imposition based on the gross revenues received by the utility. Per Commission Rule 14-2-608 (D)(5).

A 1 ½ % late payment penalty will be applied to account balances not paid within fifteen (15) days after the postmark of the bill in accordance with Arizona Administrative Code R14-2-608(F).

ISSUED: June 30, 2017
Month Day Year

EFFECTIVE: July 1, 2017
Month Day Year

ISSUED BY: Sheryl Hubbard, Director, Regulatory & Rates
2355 W. Pinnacle Peak Rd., Phoenix, AZ 85027

APPROVED FOR FILING
DECISION #: 76162

LOW INCOME PROGRAM TARIFF

LOW INCOME PROGRAM

The Low Income Program offered by the Company is designed as a short-term relief program. The program provides assistance to residential customers in the Arizona Wastewater District. Customers must complete the Low Income Application and provide necessary documentation to show they meet the qualifying guidelines. Details can be found in the Company's Low Income Surcharge Plan of Administration.

Availability

Customer that meet the eligibility requirements shall be enrolled in the Low Income Program on a first come, first served basis up to a maximum level of 5,000 participants.

To qualify, applicants must:

- Demonstrate in-state residency.
- Must be the primary account holder or a person residing in housing in a homeowner's association, apartment complex or mobile home park.
- Not be claimed as a dependent on another person's tax return
- Not have gross annual household income that exceeds 150% of the Federal Poverty Guidelines for the current year (to be updated annually).

Low Income Credit

Those customers that are the primary account holder will receive a monthly credit of \$10.00 on their bill.

Low Income Surcharge

The low income discount will be recovered by adding a monthly surcharge to all wastewater ratepayers. The total annual program costs will be calculated by multiplying the total planned participation by the \$10.00 discount rate divided by the total customer count multiplied by 12. The total annual program costs will be split between residential and commercial customers by determining the ratio of residential and commercial revenues. The residential portion will be divided by the total number of residential billing units to get a flat monthly surcharge rate. Whereas, the commercial portion will be divided by total monthly usage to get a commodity surcharge rate. Customers will see the following charge on their bill:

All Customers	\$0.75 Flat Rate per unit per month
---------------	-------------------------------------

Terms and Conditions

All rates in this Schedule shall be subject to their proportionate part of any taxes or other governmental imposts which are assessed directly or indirectly on the basis of revenues derived from service under this Schedule.

ISSUED: November 3, 2017 EFFECTIVE: July 1, 2017
Month Day Year Month Day Year

ISSUED BY: Sheryl Hubbard, Director, Regulatory & Rates
2355 W. Pinnacle Peak Rd., Phoenix, AZ 85027

APPROVED FOR FILING DECISION #: <u>76162</u>
--

DEPLOYED SERVICE MEMBER PROGRAM TARIFF

DEPLOYED SERVICE MEMBER PROGRAM

The Deployed Service Member Program is designed as a temporary relief program for service members serving away from their primary residences for an extended period of time. The program provides relief to service members who are residential customers in the Arizona Wastewater District. Details can be found in the Company's Low Income Surcharge Plan of Administration.

Availability

Customers must complete the Deployed Service Member Credit Program Application and provide necessary documentation to show they meet the qualifying guidelines. A maximum of 250 service members may be enrolled in the program at any time. Enrollment in the program must be determined on a first come, first served basis.

To qualify for this program, a service member must:

- Be on active duty for the Army, Navy, Marines, Air Force, Coast Guard, or National Guard.
- Be deployed, on a deployment that is not a "permanent change of station" and is not on a short-term deployment in which a spouse and/or dependents remain stateside.
- Have the residence in EPCOR's service area as the service member's primary residence, not a secondary to another primary residence.
- Not have any family living in the residence in EPCOR's service area during the service member's absence.

Each service member's eligibility must be determined based on written orders from the service member's command. Each service member's continued eligibility must be determined periodically through a recertification process.

Deployed Service Member Credit

Those qualified customers, during a service member's enrollment, the program will provide a monthly bill credit covering the enrolled service member's entire monthly wastewater bill.

Funding

EPCOR will defer all costs of the program for recovery in EPCOR's next general wastewater rate case.

Terms and Conditions

All rates in this Schedule shall be subject to their proportionate part of any taxes or other governmental imposts which are assessed directly or indirectly on the basis of revenues derived from service under this Schedule.

ISSUED: November 3, 2017
Month Day Year

EFFECTIVE: July 1, 2017
Month Day Year

ISSUED BY: Sheryl Hubbard, Director, Regulatory & Rates
2355 W. Pinnacle Peak Rd., Phoenix, AZ 85027

Decision No. 76162

APPROVED FOR FILING

DECISION #: 76162

EPCOR Water Arizona, Inc.
(Name of Company)

Arizona Wastewater District
(Name of Service Area)

Tax Cuts and Jobs Act ("TCJA") Tariff Rider - On-Going Monthly Credit

Description

Decision No. 76595 (February 26, 2018) in Docket No. AU-00000-17-0379, ordered EPCOR Water Arizona Inc. to file a plan to address the rate making implications of the TCJA. This tariff rider provides ongoing relief to customers in the form of a credit, on a per unit basis, to their bills as a separate line item. The credit includes taking into account the decrease in the federal income tax rate from 34 percent to 21 percent; and changes to the annual amortization of any resulting excess accumulated deferred income tax ("ADIT") compared to what was in the adjusted test years for wastewater. This credit will be in effect until the next wastewater rate case is finalized.

Availability

Applicable to all customers

Schedule of Credits for changes and adjustments to Federal Income Tax due to TCJA

Effective starting August 1, 2018

	Monthly Credit
Residential Units	\$ (1.26)
Commercial Unit 5/8 Inch	(1.50)
Commercial Unit 3/4 Inch	(1.50)
Commercial Unit 1 Inch	(1.50)
Commercial Unit LG 1 1/2 Inch	(9.73)
Commercial Unit LG 2 Inch	(9.73)
Commercial Unit LG > 2 Inch	(9.73)
Commercial Single Unit No Water	(1.50)
Commercial Laundry Non-Water	(1.50)
Commercial Hotel Non-Water	(1.50)
Mobile Home	(9.73)
OPA	(16.44)
Effluent	(133.03)
Wholesale OWU	\$ (2,219.86)

ISSUED: June 26, 2018 EFFECTIVE: August 1, 2018
Month Day Year Month Day Year

ISSUED BY: Sheryl L. Hubbard, Director, Regulatory and Rates
2355 W. Pinnacle Peak Rd., Phoenix, AZ 85027

Decision No. 76772

APPROVED FOR FILING
DECISION #: 76772

EPCOR Water Arizona, Inc.
(Name of Company)

SHEET NO. 8a

Arizona Wastewater District
(Name of Service Area)

Special Conditions

Terms and Conditions set forth in Sheet 1h apply, including calculation of any proportionate share of any privilege, sales or use tax, or other imposition based on the gross revenues received by the Company. Credit will not apply to any wastewater services resold or provided to others.

ISSUED: June 26, 2018 EFFECTIVE: August 1, 2018
Month Day Year Month Day Year
ISSUED BY: Sheryl L. Hubbard, Director, Regulatory and Rates
2355 W. Pinnacle Peak Rd., Phoenix, AZ 85027

Decision No. 76772

APPROVED FOR FILING

DECISION # 76772

EPCOR Water Arizona, Inc.
(Name of Company)

Arizona Wastewater District
(Name of Service Area)

Tax Cuts and Jobs Act ("TCJA") Tariff Rider – One-Time Credit

Description

Decision No. 76595 (February 26, 2018) in Docket No. AU-00000-17-0379, ordered EPCOR Water Arizona Inc. to file a plan to address the rate making implications of the TCJA. This tariff rider provides a one-time credit, on a per unit basis, to customers for the savings received between January 1, 2018, and through June 30, 2018. The credit includes taking into account the decrease in the federal income tax rate from 34 percent to 21 percent; and changes to the annual amortization of any resulting excess accumulated deferred income tax ("ADIT") compared to what was in the adjusted test years for wastewater.

Availability

Applicable to all permanent customers – to be applied on customer bills for the July 2018 billing cycle.

Schedule

	One-time Credit
Residential Units	\$ (7.56)
Commercial Unit 5/8 Inch	(9.00)
Commercial Unit ¾ Inch	(9.00)
Commercial Unit 1 Inch	(9.00)
Commercial Unit LG 1 ½ Inch	(58.38)
Commercial Unit LG 2 Inch	(58.38)
Commercial Unit LG > 2 Inch	(58.38)
Commercial Single Unit No Water	(9.00)
Commercial Laundry Non-Water	(9.00)
Commercial Hotel Non-Water	(9.00)
Mobile Home	(58.38)
OPA	(98.64)
Effluent	(798.18)
Wholesale OWU	\$ (13,319.16)

ISSUED: June 26, 2018 EFFECTIVE: July 1 2018
Month Day Year Month Day Year

ISSUED BY: Sheryl L. Hubbard, Director, Regulatory and Rates
2355 W. Pinnacle Peak Rd., Phoenix, AZ 85027

Decision No. 76772

APPROVED FOR FILING

DECISION #: 76772

EPCOR Water Arizona, Inc.
(Name of Company)

SHEET NO. 8c.

Arizona Wastewater District
(Name of Service Area)

Conditions

Terms and Conditions set forth in Sheet 1h apply, including calculation of any proportionate share of any privilege, sales or use tax, or other imposition based on the gross revenues received by the Company. Credit will not apply to any wastewater services resold or provided to others.

ISSUED: June 26, 2018 EFFECTIVE: July 1 2018
 Month Day Year Month Day Year

ISSUED BY: Sheryl L. Hubbard, Director, Regulatory and Rates
2355 W. Pinnacle Peak Rd., Phoenix, AZ 85027

Decision No. 76772

APPROVED FOR FILING
DECISION #: 76772

Exhibit 9
Estimated Annual Operating Revenue and Expenses

Line No.		Year 1	Year 2	Year 3	Year 4	Year 5
1	Projected Incremental Revenue:					
2	Residential	24,186	97,655	172,913	248,170	302,373
3	Commercial	-	-	-	-	-
4	Industrial	-	-	-	-	-
5	Irrigation	-	-	-	-	-
6	Total Projected Annual Revenue	\$ 24,186	\$ 97,655	\$ 172,913	\$ 248,170	\$ 302,373
7	Projected Incremental Expenses:					
8	Labor	\$ -	\$ -	\$ -	\$ -	\$ -
9	Purchased Water	\$ 0	\$ 2	\$ 3	\$ 5	\$ 6
10	Fuel & Power	\$ 1,839	\$ 8,016	\$ 14,194	\$ 20,371	\$ 24,821
11	Chemicals	\$ 600	\$ 2,616	\$ 4,632	\$ 6,648	\$ 8,100
12	Waste Disposal & Other Utilities	\$ 4,153	\$ 18,107	\$ 32,062	\$ 46,016	\$ 56,066
13	Intercompany Support Services	\$ -	\$ -	\$ -	\$ -	\$ -
14	Corporate Allocation	\$ -	\$ -	\$ -	\$ -	\$ -
15	Contracted Services	\$ 317	\$ 1,382	\$ 2,448	\$ 3,513	\$ 4,280
16	Group Insurance	\$ -	\$ -	\$ -	\$ -	\$ -
17	Pensions	\$ -	\$ -	\$ -	\$ -	\$ -
18	Regulatory Expense	\$ -	\$ -	\$ -	\$ -	\$ -
19	Insurance & License Fees	\$ -	\$ -	\$ -	\$ -	\$ -
20	Customer Accounting	\$ 1,057	\$ 4,611	\$ 8,164	\$ 11,717	\$ 14,276
21	General Office/Rent	\$ -	\$ -	\$ -	\$ -	\$ -
23	Miscellaneous	\$ 136	\$ 594	\$ 1,051	\$ 1,508	\$ 1,838
24	Maintenance Expense	\$ 527	\$ 2,299	\$ 4,072	\$ 5,844	\$ 7,120
25	Depreciation	\$ 27,975	\$ 65,223	\$ 74,495	\$ 74,495	\$ 74,495
26	Amortization of CIAC	\$ -	\$ -	\$ -	\$ -	\$ -
27	General Taxes-Other	\$ 197	\$ 860	\$ 1,522	\$ 2,185	\$ 2,662
28	Property Taxes	\$ 2,041	\$ 8,901	\$ 15,760	\$ 22,619	\$ 27,559
29	Income Taxes (at 24.5%)	\$ (3,591)	\$ (3,664)	\$ 3,555	\$ 13,046	\$ 19,882
30	Total Projected Incremental Expenses	\$ 35,253	\$ 108,946	\$ 161,957	\$ 207,966	\$ 241,104
31	Projected Net Income	\$ (11,067)	\$ (11,291)	\$ 10,956	\$ 40,203	\$ 61,269

File

Location <F:\Rates\Arizona\CC&N Cases\2020 Agua Fria WW - Enclave\Supporting Documents>

		Year 1	Year 2	Year 3	Year 4	Year 5
Enclave	Residential - Single Family					
	No. of New 5/8" Residential Customers	50	168	168	168	121
	Total No. of Residential Customers	50	218	386	554	675
Monthly Basic Charge* - 5/8"		\$ 40.31	\$ 37.33	\$ 37.33	\$ 37.33	\$ 37.33
5/8" - Residential Basic Revenues		\$ 24,186	\$ 97,655	\$ 172,913	\$ 248,170	\$ 302,373
Total Basic Revenues		\$ 24,186	\$ 97,655	\$ 172,913	\$ 248,170	\$ 302,373
* Includes TCJA Rider; excludes Low Income Program surcharge; reflects Step 5 rates effective July 1, 2021 in mid-Year 1 and thereafter						
		Year 1	Year 2	Year 3	Year 4	Year 5
Volumetric Revenues (Includes Interim Surcharge)						
5/8" - Residential		\$ -	\$ -	\$ -	\$ -	\$ -
Total		\$ -	\$ -	\$ -	\$ -	\$ -
		Year 1	Year 2	Year 3	Year 4	Year 5
Residential		\$ 24,186	\$ 97,655	\$ 172,913	\$ 248,170	\$ 302,373
Commercial		\$ -	\$ -	\$ -	\$ -	\$ -
Industrial		\$ -	\$ -	\$ -	\$ -	\$ -
Total Revenues		\$ 24,186	\$ 97,655	\$ 172,913	\$ 248,170	\$ 302,373
		Year 1	Year 2	Year 3	Year 4	Year 5
Average Monthly Bill						
Residential 5/8"		\$ 40.31	\$ 37.33	\$ 37.33	\$ 37.33	\$ 37.33

File Location

<F:\Rates\Arizona\CC&N Cases\2020 Agua Fria WW - Enclave\Supporting Documents>

Total Water Treated	Avg. Monthly Usage	Year 1	Year 2	Year 3	Year 4	Year 5
Enclave	Residential - Single Family					
Res Monthly Water Usage per Cust (in Kgal)	7.2					
Total Annual Est Water Used (Kgal)		4,320	18,835	33,350	47,866	58,320

<F:\Rates\Arizona\CC&N Cases\2020 Agua Fria WW - Enclave\Supporting Documents>

		12/31/2019	Year 1	Year 2	Year 3	Year 4	Year 5
Total Water Treated (kG)		2,877,762	2,877,762	2,882,082	2,896,597	2,911,112	2,925,628
Additional Usage		-	4,320	14,515	14,515	14,515	10,454
Total Usage	Factor	2,877,762	2,882,082	2,896,597	2,911,112	2,925,628	2,936,082
Cumulative % Change	1		0.2%	0.7%	1.2%	1.7%	2.0%
		12/31/2019	Year 1	Year 2	Year 3	Year 4	Year 5
Number of Customers		59,240	59,240	59,290	59,458	59,626	59,794
Additional Customers			50	168	168	168	121
Total Customers	Factor	59,240	59,290	59,458	59,626	59,794	59,915
Cumulative % Change	2		0.1%	0.4%	0.7%	0.9%	1.1%

Description	Growth Factor	12/31/2019						
		Agua Fria Expenses	Incremental Increase					Year 5
			Year 1	Year 2	Year 3	Year 4		
Labor		\$ 1,816,060	\$ -	\$ -	\$ -	\$ -	\$ -	\$ -
Purchased Water	1	\$ 285	\$ 0	\$ 2	\$ 3	\$ 5	\$ 6	\$ 6
Fuel & Power	1	\$ 1,224,765	\$ 1,839	\$ 8,016	\$ 14,194	\$ 20,371	\$ 24,821	\$ 24,821
Chemicals	1	\$ 399,667	\$ 600	\$ 2,616	\$ 4,632	\$ 6,648	\$ 8,100	\$ 8,100
Waste Disposal & Other Utilities	1	\$ 2,766,552	\$ 4,153	\$ 18,107	\$ 32,062	\$ 46,016	\$ 56,066	\$ 56,066
Contracted Services	2	\$ 375,630	\$ 317	\$ 1,382	\$ 2,448	\$ 3,513	\$ 4,280	\$ 4,280
Group Insurance & Other Employee Benefits		\$ 618,894	\$ -	\$ -	\$ -	\$ -	\$ -	\$ -
Insurance Other Than Group		\$ 219,762	\$ -	\$ -	\$ -	\$ -	\$ -	\$ -
Customer Accounting	2	\$ 1,252,884	\$ 1,057	\$ 4,611	\$ 8,164	\$ 11,717	\$ 14,276	\$ 14,276
Rents		\$ 191	\$ -	\$ -	\$ -	\$ -	\$ -	\$ -
General Office Expense		\$ 217,648	\$ -	\$ -	\$ -	\$ -	\$ -	\$ -
Miscellaneous	2	\$ 161,287	\$ 136	\$ 594	\$ 1,051	\$ 1,508	\$ 1,838	\$ 1,838
Maintenance Expense	2	\$ 624,861	\$ 527	\$ 2,299	\$ 4,072	\$ 5,844	\$ 7,120	\$ 7,120
Property Taxes	1	\$ 1,359,887	\$ 2,041	\$ 8,901	\$ 15,760	\$ 22,619	\$ 27,559	\$ 27,559
General Taxes-Other	1	\$ 131,362	\$ 197	\$ 860	\$ 1,522	\$ 2,185	\$ 2,662	\$ 2,662
Depreciation		\$ 10,054,861	\$ 27,975	\$ 65,223	\$ 74,495	\$ 74,495	\$ 74,495	\$ 74,495
CIAC Amort		\$ -	\$ -	\$ -	\$ -	\$ -	\$ -	\$ -
Total Estimated Expenses		\$ 21,224,596	\$ 38,844	\$ 112,610	\$ 158,402	\$ 194,920	\$ 221,223	\$ 221,223

File Location <F:\Rates\Arizona\CC&N Cases\2020 Agua Fria WW - Enclave\Supporting Documents>

Line No.	Parcel	Plant Additions:	Year 1	Year 2	Year 3	Year 4	Year 5	Total
1	Parcel 1	Enclave						
2		EPCOR Paid	\$ -	\$ -	\$ -	\$ -	\$ -	\$ -
3		Developer Paid	\$ 1,029,010	\$ 669,234	\$ -	\$ -	\$ -	\$ 1,698,244
4	Offsite							
5		EPCOR Paid	\$ -	\$ -	\$ -	\$ -	\$ -	\$ -
6		Developer Paid	\$ 990,041	\$ -	\$ -	\$ -	\$ -	\$ 990,041
7	Total							
8		EPCOR Paid (Ln 2 + Ln 5)	\$ -	\$ -	\$ -	\$ -	\$ -	\$ -
9		Developer Paid (Ln 3 + Ln 6)	\$ 2,019,051	\$ 669,234	\$ -	\$ -	\$ -	\$ 2,688,285
10								
11		Sustaining capital:						
12		EPCOR Paid	\$ -	\$ -	\$ -	\$ -	\$ -	\$ -
13		Total (Ln 8 + Ln 9 + Ln 12)	\$ 2,019,051	\$ 669,234	\$ -	\$ -	\$ -	\$ 2,688,285
14								
15		Total EPCOR Cumulative Utility Plant	\$ 2,019,051	\$ 2,688,285	\$ 2,688,285	\$ 2,688,285	\$ 2,688,285	\$ 2,688,285
16								
17		Composite Depreciation Rate - Agua Fria	2.77%	2.77%	2.77%	2.77%	2.77%	
18								
19		Annual Depreciation Expense on New Plant (Ln 10 x Ln 14)	\$ 55,950	\$ 18,545	\$ -	\$ -	\$ -	
20		Depr In Year of Completion Under Mid-Year Convention	\$ 27,975	\$ 9,273	\$ -	\$ -	\$ -	
21								
22		Depreciation on Year 1 Additions	\$ 27,975	\$ 55,950	\$ 55,950	\$ 55,950	\$ 55,950	\$ 251,776
23		Depreciation on Year 2 Additions		\$ 9,273	\$ 18,545	\$ 18,545	\$ 18,545	\$ 64,908
24		Depreciation on Year 3 Additions			\$ -	\$ -	\$ -	\$ -
25		Depreciation on Year 4 Additions				\$ -	\$ -	\$ -
26		Depreciation on Year 5 Additions					\$ -	\$ -
27								
28		Cumulative Depreciation Expense	\$ 27,975	\$ 65,223	\$ 74,495	\$ 74,495	\$ 74,495	\$ 316,684
29								
30		Offsetting CIAC Amortization	\$ -	\$ -	\$ -	\$ -	\$ -	\$ -
31		Total Depreciation Expense	\$ 27,975	\$ 65,223	\$ 74,495	\$ 74,495	\$ 74,495	\$ 316,684

File F:\Rates\Arizona\CC&N_Cases\2020 Agua Fria WW - Enclave\Supporting Documents

Exhibit 10
Proposed Construction Timeline

Proposed Construction Timeline by Phase			
Phase	Number of Lots ¹	Start Date	Completion Date
1A	24	07/01/21	10/01/21
1B	234	07/01/21	10/01/21
2	151	10/01/21	01/01/22
3	172	01/01/22	10/01/22
4	94	07/01/22	01/01/23

¹ Number of lots served by sewers installed in each phase

Exhibit 11
Request for Service Letter

Eyherabide Properties, LLC
&
Vincent and Rose-Ann Eyherabide Family Trust

18912 W. Indian School Road
Litchfield Park, Arizona 85340

January 6, 2020

Brad Finke, P.E.
Engineering Manager
EPCOR
2355 W. Pinnacle Peak Road, Suite 300
Phoenix, AZ 85027

RE: Request for Sewer Service – Eyherabide Property (NWC Indian School & Perryville)

Dear Mr. Finke:

This letter serves as a formal request for EPCOR Water Arizona Inc. to expand its sanitary sewer service area to include the Eyherabide property (APN's 502-29-006S, -006T, -016B, -016D, -016F, -016G, -016H, -024, -025, -042A and -042B) located at the NWC of Indian School Road and Perryville Road in Maricopa County, Arizona. No portion of this property is currently within EPCOR's sewer CC&N service area.

The requested expansion area covers approximately 181 acres located in the East Half of Section 21, Township 2 North, Range 2 West of the Gila and Salt River Meridian. The expansion area identified in this request is not currently served by any sewer utilities.

I appreciate your consideration of this request. Please feel free to contact Chris Webb with Rose Law Group pc at (480) 240-5648 or cwebb@roselawgroup.com if you need additional information.

Respectfully submitted,

Eyherabide Properties, LLC and the Vincent and Rose-Ann Eyherabide Family Trust



By: Rose-Ann Eyherabide

Exhibit 12
Maps of Requested Extension Area

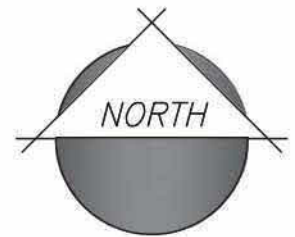

N.T.S.

19-0254

Extension Area
Maricopa County, Arizona

Figure 1: Vicinity Map



1130 N. Alma School Rd
Suite 120 Mesa, AZ 85201
T:480.503.2250 | F:480.503.2258
www.epsgroupinc.com

Figure 5: Boundary & Land Ownership Map

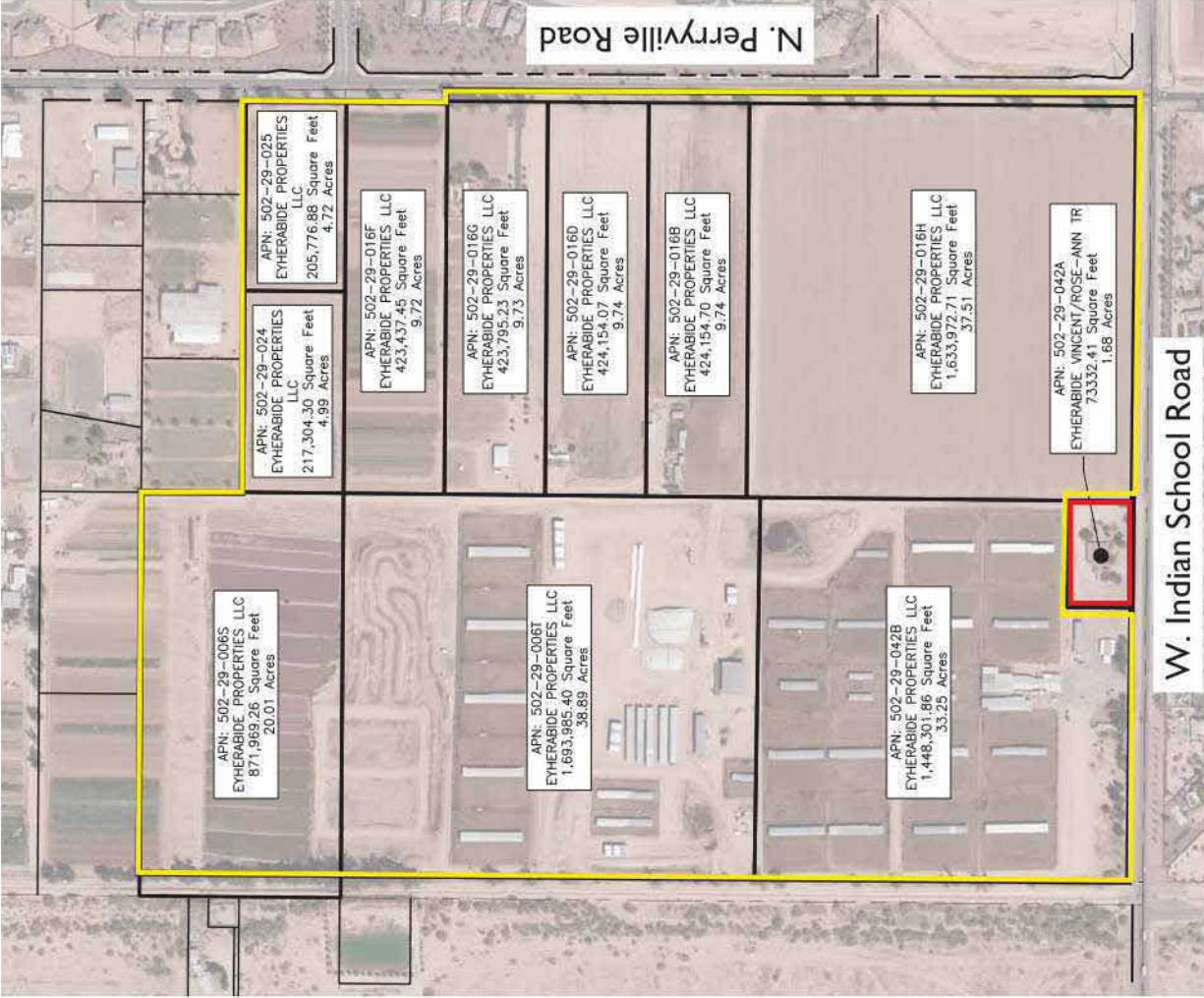
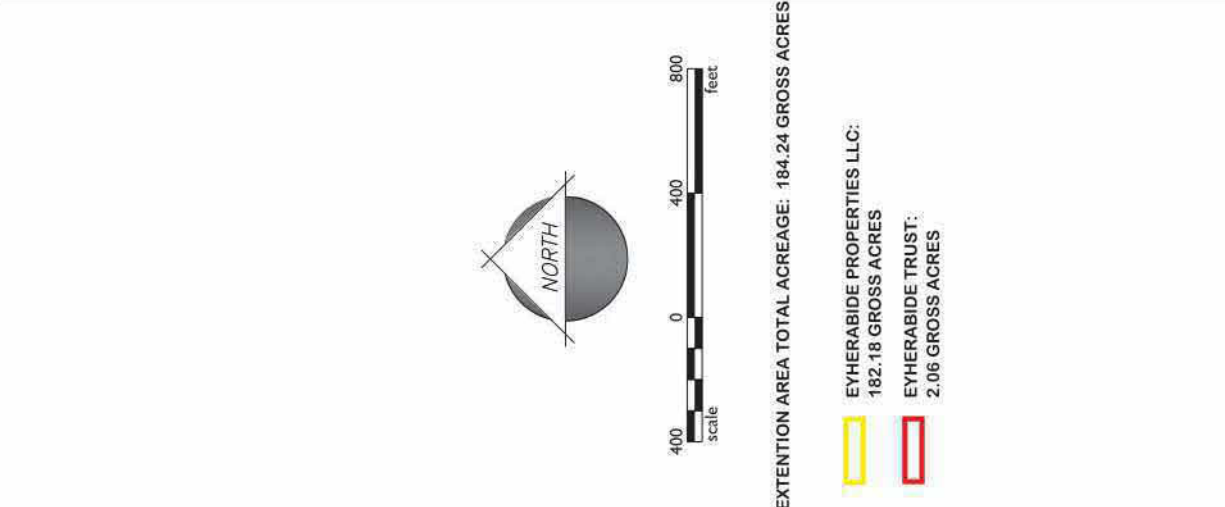

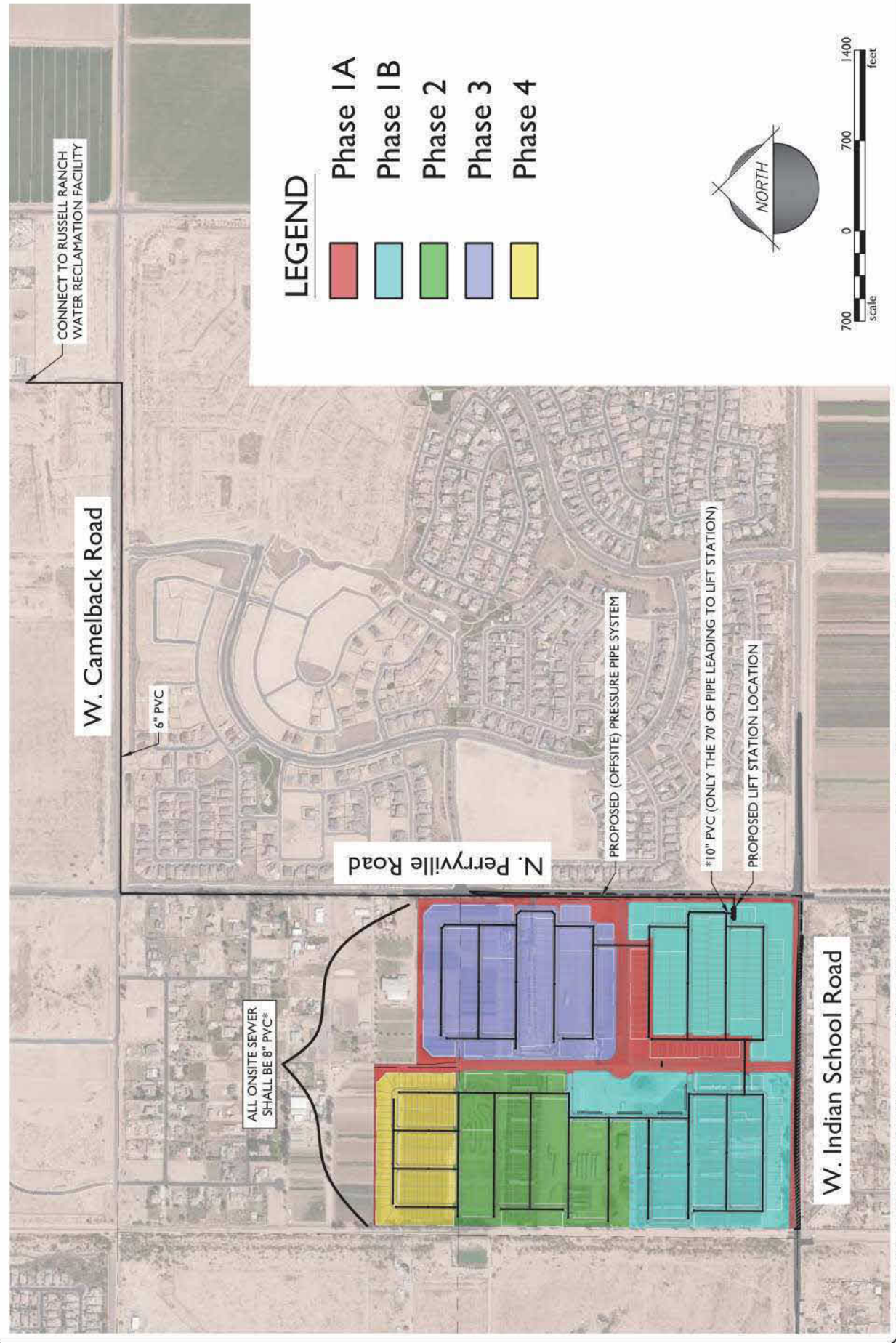

LEGEND

- Phase 1A
- Phase 1B
- Phase 2
- Phase 3
- Phase 4

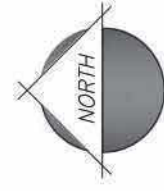

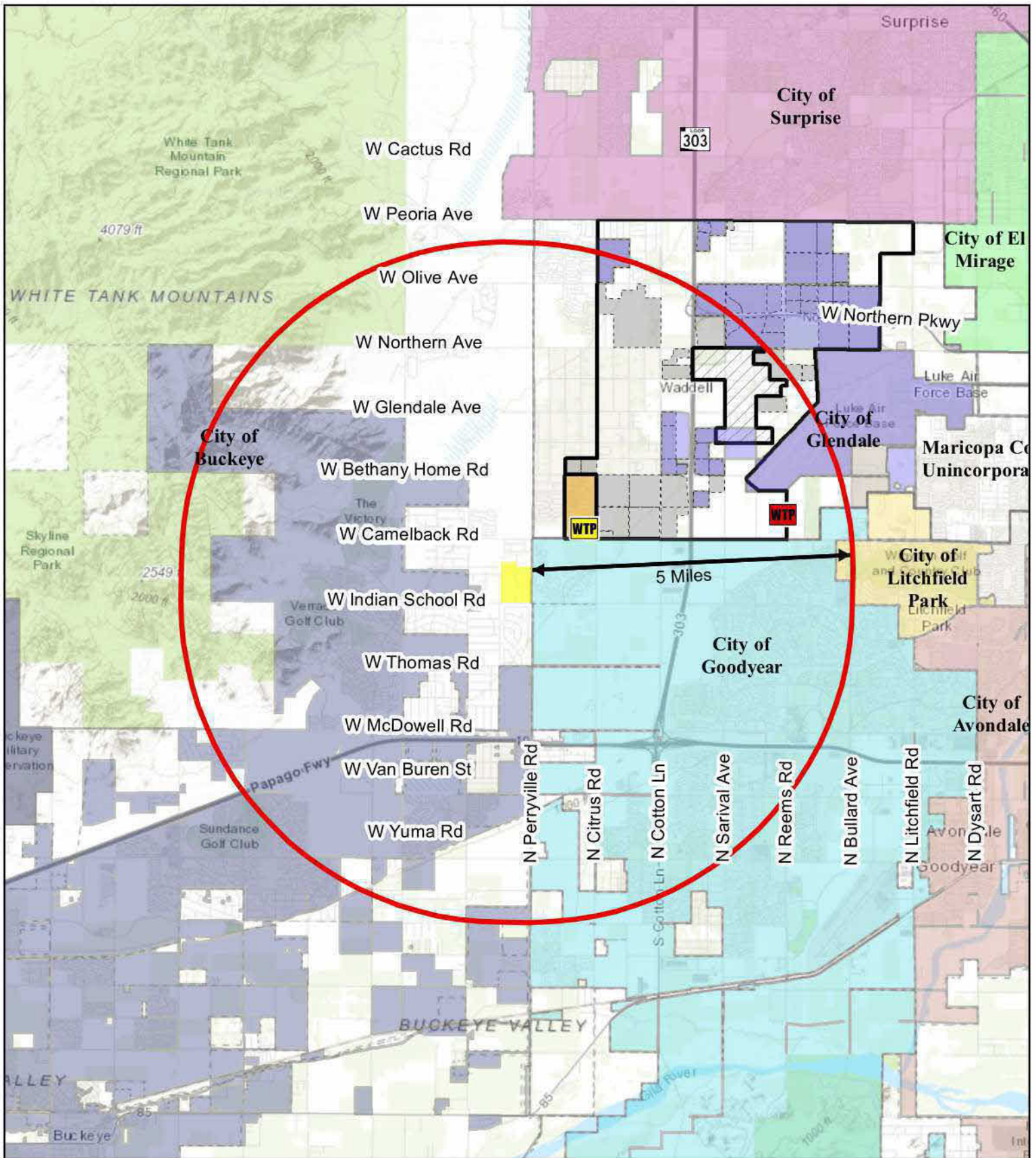

Within 5 miles of CC&N extension:

City of Buckeye	City of Litchfield Park
City of Glendale	Luke AFB
City of Goodyear	Unincorporated Maricopa County

-  EPCOR's MAG 208 Service Area
-  Luke 303 Corridor Wastewater CC&N
-  Requested Agua Fria Wastewater CC&N Extension
-  Existing Agua Fria Wastewater CC&N (Partial)
-  Luke 303 WRF
-  Russell Ranch WRF

**CC&N Extension
Agua Fria
Wastewater District**



2355 W. Pinnacle Peak Rd.
Suite 300
Phoenix, AZ 85027.

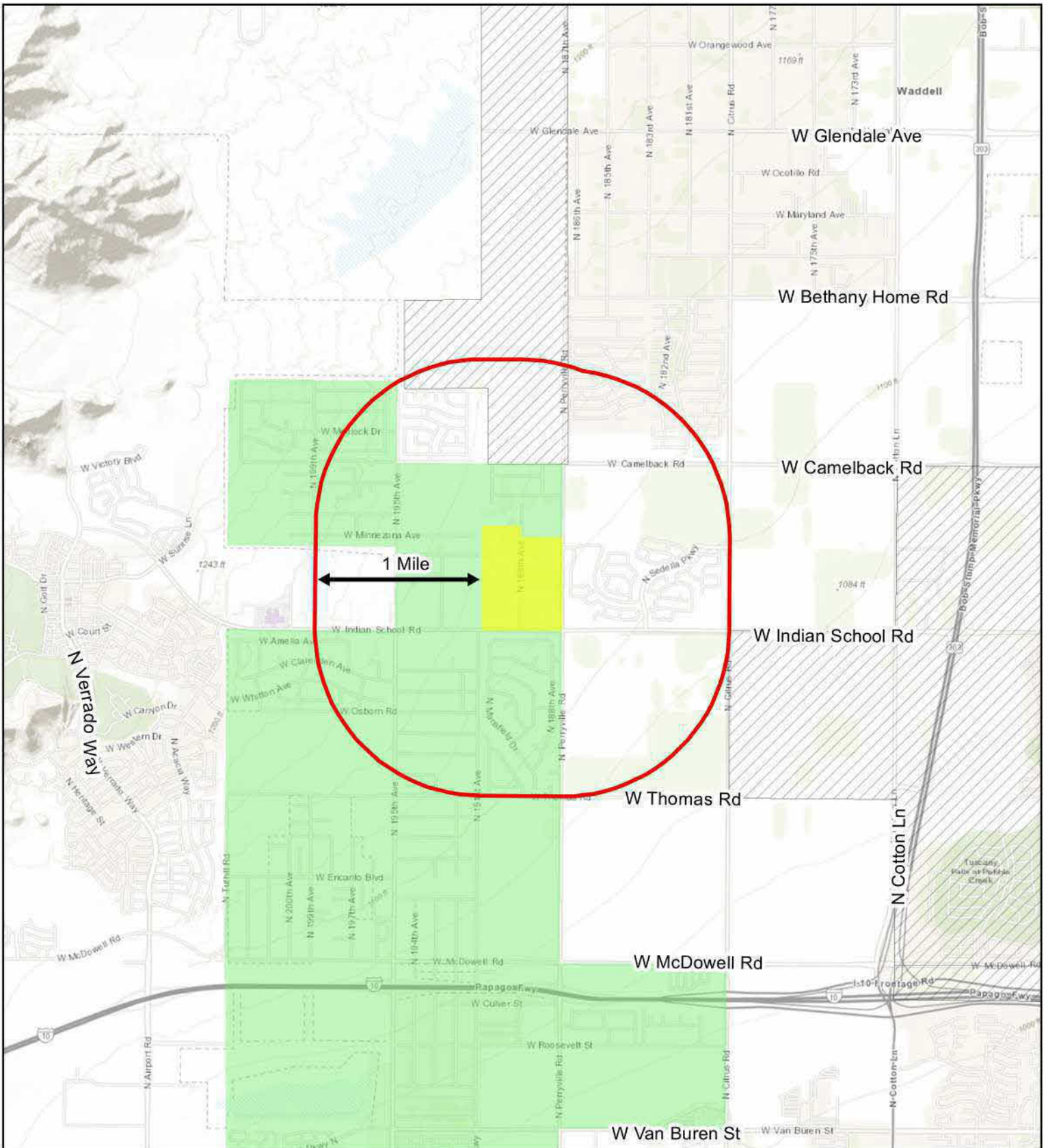

-  Requested Agua Fria Wastewater CC&N Extension
-  Arizona Water Company (Water Service)
-  Litchfield Park Service Company (Wastewater Service)

**CC&N Extension
 Agua Fria
 Wastewater District**



2355 W. Pinnacle Peak Rd.
 Suite 300
 Phoenix, AZ 85027

Exhibit 13

Proposed Form of Notice and Mailing List



2355 W Pinnacle Peak Road, Suite 300
Phoenix, AZ 85027 USA
epcor.com

INSERT DATE

INSERT NAME

City Manager

INSERT MUNICIPALITY NAME

INSERT ADDRESS 1

INSERT ADDRESS 2

Sent via e-mail to: **INSERT EMAIL ADDRESS**

Re: Application for Extension of Certificated Area

Dear **INSERT NAME**:

As the largest private water provider in Arizona, EPCOR delivers water and wastewater service to more than 670,000 people including service to municipalities and unincorporated areas of Maricopa County.

On **INSERT DATE**, EPCOR Water Arizona Inc. filed an application with the Arizona Corporation Commission (ACC) for the exclusive right to be the wastewater services provider in the Fulton Homes Enclave development, which is located near the Agua Fria area of EPCOR's existing Arizona wastewater district in an unincorporated area of Maricopa County. Enclosed is a metes and bounds description of the requested service area extension.

In order to provide service to this development, EPCOR must file an application with the ACC requesting approval to extend EPCOR's existing Certificate of Convenience and Necessity (CC&N). EPCOR's application seeks to bring the Enclave development into its existing Arizona wastewater district. EPCOR is ideally positioned to provide wastewater services to this development safely and efficiently and an extension of EPCOR's existing service area is the most economical wastewater services solution to benefit these homeowners.

A CC&N is authorized by the ACC and grants a utility the exclusive right and responsibility to provide wastewater services within a specified area under rates, charges, terms and conditions established by the ACC. A CC&N does not prohibit an individual from providing services only to themselves using their own facilities on their own property. However, other applicable laws may restrict such activity.

If EPCOR's application is granted, EPCOR will be the exclusive wastewater services provider for the Enclave development and will be required by the ACC to provide wastewater service under the rates, charges, terms and conditions established by the ACC for the Agua Fria area of the Arizona wastewater district.

EPCOR is required to provide notice of this application to any municipality within five miles of these properties. The application has been docketed by the Commission in Docket No. **INSERT NUMBER**. EPCOR's application is available on the ACC's website at azcc.gov, using the eDocket function.

Please feel free to contact me at (623) 445-2402 or bfinke@epcor.com if you have any questions.

Sincerely,

Brad W. Finke, P.E.
Engineering Manager

Enclosures

**Arizona Wastewater District, Agua Fria Area CC&N Extension
Notice of Application Mailing List**

Municipalities within 5 miles of proposed service area extension:

City of Buckeye

Roger Klingler, City Manager
530 East Monroe Avenue
Buckeye, AZ 85326
623-349-6910

City of Glendale

Kevin Phelps, City Manager
5850 W. Glendale Avenue, Suite 431
Glendale, AZ 85301
623-930-2870

City of Goodyear

Julie Arendall, City Manager
190 N. Litchfield Road
Goodyear, AZ 85338
623-882-7051

City of Litchfield Park

Bill Stephens, City Manager
214 W. Wigwam Boulevard
Litchfield Park, AZ 85340
623-935-5033

Other entities within 5 miles of proposed service area extension:

Luke Air Force Base

Lt. Col. Rusty Mitchell, USAF (Ret.)
Director, Community Initiatives Team
14185 Falcon Street
Glendale, AZ 85309
623-856-5853

Maricopa County

Eric Matson, Manager,
Environmental Services Department Water and Waste Management Division
501 N. 44th Street, Suite 200
Phoenix, AZ 85008
602-506-6616

Other wastewater service providers within 1 mile of proposed service area extension:

Liberty Utilities, Inc.

Litchfield Park Water & Sewer Corp.

Matthew Garlick, President

12725 W Indian School Rd.

Avondale, AZ 85392

Exhibit 14
Franchise Agreement

COUNTY OF MARICOPA
State of Arizona

Office of the Clerk
Board of Supervisors

State of Arizona) ss.
County of Maricopa)

I, Fran McCarroll, Clerk of the Board of Supervisors, do hereby certify that the following is a true and correct statement of the agenda item and the action taken by the Board of Supervisors at their meeting held December 12, 2018:

9. PUBLIC SERVICE FRANCHISE – EPCOR WATER ARIZONA INC.

Pursuant to A.R.S. §40-283, convene the scheduled public hearing, to solicit comments and consider the application by EPCOR Water Arizona Inc., for a public service franchise to provide domestic water and waste water utility services to the residents of Anthem, Sun City Tierra Del Rio, NE Agua Fria, Sun City, Sun City West, Agua Fria, Luke 303 Wastewater, Russell Ranch, Verrado, Chaparral and Paradise Valley, residing in Maricopa County. The hearing will also consider whether the applicant is able to adequately maintain facilities in county rights-of-way. Upon Board approval, authorize the Chairman to sign the Franchise Resolution. (Supervisory District No 2,3,4). (C-06-19-171-7-00)

Motion to approve by Supervisor Gates, seconded by Supervisor Barney

Ayes: Barney, Chucuri, Gates, Hickman, Gallardo



IN WITNESS WHEREOF, I have hereunto set my hand and affixed the Official Seal of the County of Maricopa. Done at Phoenix, the County Seat, on December 12, 2018.

Fran McCarroll
Clerk of the Board of Supervisors

BEFORE THE BOARD OF SUPERVISORS
OF
MARICOPA COUNTY, STATE OF ARIZONA

IN THE MATTER OF THE APPLICATION OF)
)
)
)
EPCOR Water Arizona Inc.) FRANCHISE
)
)
)

FOR A FRANCHISE

BE IT RESOLVED BY THE BOARD OF SUPERVISORS OF MARICOPA COUNTY, STATE OF ARIZONA, THAT:

WHEREAS, EPCOR Water Arizona Inc. hereinafter designated as the Grantee, doing business in Maricopa County, Arizona, submitted an application bearing date of January 12, 2018, praying for the right, privilege, license and franchise to construct, maintain and operate all necessary equipment along, upon, under and across public highways, roads, alleys and thoroughfares (excepting State Highways) for the supplying of domestic water and waste water utility services for a period not to exceed twenty-five (25) years or for a period of one (1) year after the franchised area or a portion thereof is annexed by a municipality, whichever is shorter, within Maricopa County, Arizona more particularly shown on the attached Exhibits and not within the confines of any incorporated city or town, and under such restrictions and limitations and upon such terms as the Board of Supervisors may provide, not inconsistent with the laws of the State of Arizona, or the orders and rules of the Corporation Commission of the State of Arizona, and that the Board take such proceedings herein as is provided by laws of the State of Arizona; and

WHEREAS, upon filing said application, the said Board of Supervisors on November 7, 2018 ordered that public notice of the intention of said Board to make such grants be given by publishing a notice in the official newspaper of Maricopa County, published in the County of Maricopa, State of Arizona, and that 9:30 a.m., on December 12, 2018, at the meeting room of said Board of Supervisors located at 205 West Jefferson Street, in the City of Phoenix, Arizona, be set as the time and place to consider the said application; and

WHEREAS, the said application coming on regularly for consideration on said day and it appearing by the affidavit of the duly authorized agent of the said time and place set for the consideration of such application has been published for at least once a week for the three-week period prior to said date set forth herein, to-wit:

In the issues of the said newspaper on November 22, 2018; November 29, 2018; and December 6, 2018 and it appearing that no sufficient protest has been filed by the qualified electors of the said County petitioning said Board of Supervisors to deny such license and franchise, and it further appearing the best interests of Maricopa County will be served by the granting of said application and the franchise referred to therein;

NOW, THEREFORE, the Board of Supervisors of Maricopa County, State of Arizona, acting on behalf of said County does hereby grant unto EPCOR Water Arizona Inc. doing business in Maricopa County, Arizona, subject to the terms, conditions and limitations hereinafter contained, the right, privilege, license and franchise to construct, maintain and operate an extension to an existing public franchise, for a

period of not to exceed twenty-five (25) years or for a period of one (1) year after the franchised area is annexed by a municipality, whichever is shorter, for the supplying of this service along, upon, under and across the public highways, roads, alleys and thoroughfares (excepting State highways) within that portion of Maricopa County, Arizona, hereinabove described, under such restrictions and limitations and upon such terms as this Board at any time may provide, not inconsistent with the laws of the State of Arizona, or the orders and rules of the Corporation Commission of the State of Arizona, specifically providing, however, that:

- 1) All rights hereunder are granted under the express condition that the Board of Supervisors of said Maricopa County shall have the power at any time to impose such restrictions and limitations and to make such regulations on such highways, roads, and thoroughfares as may be deemed best for the public safety, health, welfare and convenience.
- 2) All rights hereby granted shall be exercised so as to not interfere or conflict with any easements or rights-of-way heretofore granted by said Board of Supervisors and now in force.
- 3) All rights hereby granted shall be exercised so as not to interfere or conflict with any easement, either public or private, of whatsoever nature, which has been acquired in or to the proper use of said highway, roads, and thoroughfares, or any portion thereof.
- 4) All rights hereby granted shall be exercised so as not to interfere or conflict with or endanger in any way the proper use by the public of said highways, roads, and thoroughfares, or any portion thereof.
- 5) That the said Grantee shall bear all expenses incurred including damages and compensation for the alteration of the course, direction, surface, grade or alignment of any of the said highways, roads and thoroughfares necessarily made by the said grantee for the purpose of this franchise; that said grantee will maintain his equipment from time to time as may be needed, without the necessity of notice from Maricopa County. In the event the said grantee shall fail to make any repairs within ten days from the time same becomes necessary, then Maricopa County may cause the same to be made, and said grantee agrees to pay Maricopa County the cost thereof.
- 6) That all property of the franchise be installed and operated by the said grantee and shall be placed, removed or relocated, initially and throughout the term of this franchise, along, in, over, under and across the said highway, roads and thoroughfares, in such a manner and location as the Board of Supervisors or its duly authorized agents may designate. Such placement, removal or relocation shall be done at the sole expense of the grantee upon a determination by the Board of Supervisors of Maricopa County that such placement, removal or relocation is necessary.

If the grantee fails or refuses to so remove or relocate, Maricopa County may so remove or relocate, at the sole expense of grantee, such expense to include any and all damages and compensation of whatsoever nature arising therefrom.

In this section the term "property" includes conduits, pipe, wires, poles, or other structures and appliances used to supply or deal in gas, electricity, lights, water, heat, refrigeration, power, telephones, telegraph, television and other public utilities.

Any finding or determination made by the Board of Supervisors pursuant hereto shall be final and binding upon the grantee whether or not such findings or determinations relates to the requirements of public safety or welfare, the use of public roads or the need for proposed improvements, and whether or not the function to be served by such removal or relocation is of a governmental or proprietary nature.

- 7) That said grantee shall indemnify and save harmless, the said County of Maricopa from all costs, expense and liabilities in connection with the granting of this franchise and exercise of the same by them.
- 8) That the rights of any person claiming to be injured in any manner by the maintenance of said projects and equipment shall not be affected hereby.
- 9) That the terms and conditions of this franchise shall inure to the benefit of, and be binding upon, all the heirs and assigns of the said Grantee.
- 10) That the franchise and privilege herein granted shall not be deemed to be exclusive and the said Board of Supervisors hereby expressly reserves the right and power to grant from time to time similar franchises and privileges over the same territory and highways, roads and thoroughfares.
- 11) This franchise is granted upon the express condition that the Certificate of Convenience and Necessity be procured from the Corporation Commission of the State of Arizona within six months from the date of granting of this franchise and proof thereof submitted to the Board of Supervisors; and if such Certificate is not granted within six months from said date, then this franchise may be declared void. If the Certificate of Convenience and Necessity is not procured from the Corporation Commission within six months from the date of granting of this franchise, the franchisee may submit proof to the Board of Supervisors of application made to the Corporation Commission for the Certificate and the franchisee will be granted a six month extension for the procurement of the Certificate, for a total of twelve months from the date of granting of this franchise.
- 12) That no facilities shall be installed until the Certificate of Convenience and Necessity be procured from the Corporation Commission of the State of Arizona and such Certificate has been delivered to the Board of Supervisors.
- 13) This franchise is granted upon the express condition that all of the Property Tax obligations of the franchisee shall remain current and if such taxes are not current, then this franchise extension is deemed void.
- 14) All materials and construction methods used with the public right-of-way shall conform to the applicable standards, specifications and special provisions currently in effect in Maricopa County.
- 15) The Franchise holder shall obtain a construction permit from the Office of the County Engineer prior to construction of any facilities in the public right-of-way.

DATED this 12th day of December, 2018.



Steve Chucri, Chairman of the Board of Supervisors

ATTEST:



Fran McCarroll, Clerk of the Board of Supervisors

Maricopa County



2355 W Pinnacle Peak Rd
Phoenix, AZ 85027

Revised: January 10, 2018
File name:
EPCOR_MaricopaCounty_ServiceAreas.mxd

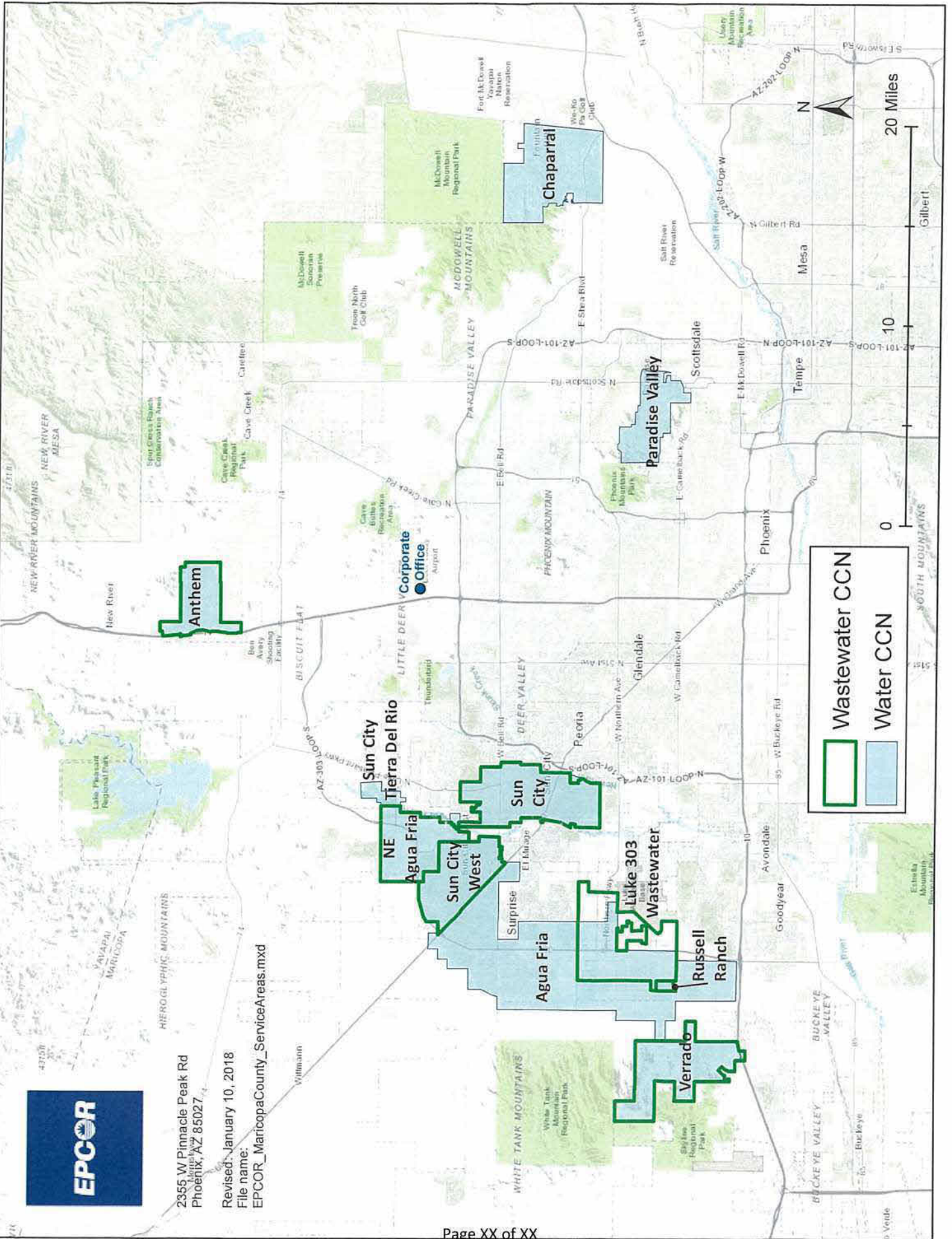

Exhibit 15
ADEQ Compliance Status Reports



2355 W Pinnacle Peak Road, Suite 300
 Phoenix, AZ 85027 USA
epcor.com

October 15, 2020

Records Center
 Arizona Department of Environmental Quality
 1110 West Washington Street
 Phoenix, AZ 85007

RE: Request for Compliance Status Reports

Dear Madam or Sir,

EPCOR Water Arizona Inc. will file an application with the Arizona Corporation Commission (ACC) for extension of the Certificate of Convenience and Necessity (CC&N) for the Agua Fria area of its Arizona wastewater district. The following information must be provided with the application pursuant to Arizona Administrative Code R14-2-602(B)(5)(dd)(i):

A current compliance status report from the Arizona Department of Environmental Quality, dated no more than 30 days before the date the CC&N extension application is filed, for each wastewater system operated by the applicant, as identified by a separate Arizona Department of Environmental Quality Identification Number.

This letter is to request compliance status reports for the following wastewater systems:

Facility Name	Aquifer Protection Permit ID#	AZPDES Permit ID#
Anthem WWRF	103259	AZ0025429
Gateway WWTP	105010	NA
Luke 303 WWRF	511700	NA
Verrado WWRF	105202	AZ0026794
Rio Verde WWRF	100197	NA
Northwest Valley WWRF	102667	NA
Russel Ranch WWTP	105229	NA
Wishing Well WWRF	102181	NA

In response to a previous request for compliance status reports for other facilities, ADEQ staff informed EPCOR that the reports are no longer available for any wastewater facilities. Rather, staff indicated that the compliance status of any wastewater facility is documented in the compliance files which include inspection reports and notices.

If compliance status reports for the subject wastewater facilities remain unavailable, please provide the

most recent compliance files with inspection reports and notices. Please provide the files in hardcopy or digital format to:

Peter Ewen
Director, Regulatory
EPCOR Water Arizona Inc.
2355 W. Pinnacle Peak Rd, Suite 300
Phoenix, AZ 85027

Thank you for your assistance in this matter. Please feel free to contact me with any questions that you may have.

Sincerely,



Peter M. Ewen
Director, Regulatory
pewen@epcor.com
623.587.5222

Exhibit 16
Wastewater Flow Data Sheet

Agua Fria Area,
Arizona Wastewater District
Wastewater Flow Data Sheet

Month - Year	Number of Customers	Influent Average Daily Flow (gpd)
Jan-2019	231	38,732
Feb-2019	233	34,788
Mar-2019	232	34,782
Apr-2019	235	32,396
May-2019	235	32,286
Jun-2019	236	30,965
Jul-2019	236	29,766
Aug-2019	237	31,604
Sep-2019	237	30,385
Oct-2019	238	33,505
Nov-2019	239	36,920
Dec-2019	241	36,253
Jan-2020	242	34,999
Feb-2020	245	35,797
Mar-2020	246	37,966
Apr-2020	246	37,866

Exhibit 17
Affidavit

1
2
3
4
5
6
7
8
9
10
11
12
13
14
15
16
17
18
19
20
21
22
23
24
25
26
27
28

BEFORE THE ARIZONA CORPORATION COMMISSION

COMMISSIONERS

ROBERT "BOB" BURNS – Chairman
BOYD DUNN
SANDRA D. KENNEDY
JUSTIN OLSON
LEA MÁRQUEZ PETERSON

IN THE MATTER OF THE APPLICATION
OF EPCOR WATER ARIZONA INC., AN
ARIZONA CORPORATION, TO EXTEND
ITS CERTIFICATE OF CONVENIENCE
AND NECESSITY FOR ITS ARIZONA
WASTEWATER DISTRICT

DOCKET NO.

AFFIDAVIT OF PETER M. EWEN

1 State of Arizona)
2 County of Maricopa)ss.

3 PETER M. EWEN, being duly sworn, deposes and says:

4 1. I am a resident of Maricopa County, over 18 years of age, and make this
5 affidavit based on my own personal knowledge.

6 2. I am Director of Regulatory for EPCOR Water Arizona Inc. (the "Company").

7 3. I hereby certify that the Company's Application to Extend Existing Certificate
8 of Convenience and Necessity to Include Additional Territory, dated October 20, 2020 was
9 prepared and filed under my direct supervision.

10 4. The Company submits this affidavit in accordance with A.A.C. R14-2-
11 602(B)(5)(ee).

12 Dated this 20th day of October, 2020.

13 
14 _____
15 Peter M. Ewen

16
17 SUBSCRIBED AND SWORN to before me this 20th day of October, 2020 by Peter M.
18 Ewen

19 
20 _____
21 Notary Public

21 My Commission Expires:
22 August 14, 2022

